



**ISSN: 2454-9940**



**INTERNATIONAL JOURNAL OF APPLIED  
SCIENCE ENGINEERING AND MANAGEMENT**

**E-Mail :**  
**editor.ijasem@gmail.com**  
**editor@ijasem.org**

**[www.ijasem.org](http://www.ijasem.org)**

# AUTOMATED STREET LIGHT CONTROL AND MANHOLE MONITORING

Dr. Md. Shahbaz Khan, D.Rajesh, O.Ramesh, K.Prem Kumar, A.Bharath

## IMPLEMENTATION OF STREET LIGHT CONTROL WITH MANHOLE MONITORING

---

**ABSTRACT:** This project represents the implementation and design function of Street light automation, Underground Drainage and Manhole Monitoring System using GSM technology. The vital considerations of this design are low cost, low maintenance, fast deployment, and high number of sensors, long life-time and high quality of service. The proposed model provides a system for automatic control of the street lights, street lights working condition, water level inside a manhole and also checks whether a manhole lid is open. In real time, this system can remotely monitor current states of the street lights, manholes and water level in them and will alert the officials early by sending a SMS through the GSM.

---

**Keywords:** Monostable circuit using IC 555 timer, fault detection, red indicators, man hole water level monitoring, GSM

---

### INTRODUCTION

The project work described here is quite useful for the state electricity and municipal departments, generally the line men either he belongs electricity department or municipality, it is the duty of him to energize the street lights in the evening, preferably after Sun set, and he is supposed to be switched off these lights in early in the morning, when the Sun is raised again. But

unfortunately, due to many reasons the line men may forget to switch off these lights in the morning[1]. Often at many places these lights remain in on condition during the day time also, this is because of the negligence of line men. In this regard lot of energy is wasted, resulting power cuts. There are many

reasons for power cuts, in that list this reason also can be added and it can be underlined. This project work also deals with password-based phase line controller is a simple project that helps in controlling the electrical line with help of a password. Now a day's electrical accidents to the line men are increasing while repairing the electrical lines. This is due to the lack of proper communication between the electrical sub-station and the maintenance staff. This project gives a solution to this problem to ensure the safety of the line man. In this proposed project work, the control (ON/OFF) of the electrical line lies with the line man. The concept is designed such that maintenance staff or the line man has to enter the password to switch ON/OFF the electrical line. If there is any fault in the electrical line or any repair is to be done to the line, then the supply to the electrical line is cut off by entering the password and can comfortably repair the line. After repairing the line, by entering the password again, supply to the electrical line will be restored. Separate passwords can be assigned to different electrical phase lines. The system is designed with a single line with two different passwords. At the output a relay is connected and this relay contact is used to make or break supply to the electrical line. Presently the demo module

is constructed with two street lights all of them can be controlled through the password. Most of the cities adopted the underground drainage system and it is the duty of managing station (Municipal Corporation) to maintain cleanliness of the cities. If the drainage maintenance is not proper the pure water gets contaminate with drainage water and infectious diseases may get spread. The drainage gets blocked during rainy season, it will create problem for routine life such as traffic may get jammed, the environment becomes dirty, and totally it upsets the public. Suppose if there should be a facility which would be there in Municipal Corporation (managing station) that the officials come to know immediately after blocking of drainage in which area and the exact place where it is blocked and it also informs if the manhole lid is open. So our main focus is monitoring manholes using sensors. If drainage gets blocked and water overflows, and if manhole lid is opens, it is sensed by the sensors, then that sensor sends information via GSM module which is located in that area to the corresponding managing station.

**FUNCTIONAL DESCRIPTION OF THE PROJECT** The detailed circuit description of the project work is explained along with circuit diagram. For better understanding total circuit diagram is

divided into various sections and each section circuit description with its circuit diagram is provided in this chapter. One part of project describes about monitoring the line that is not working and inform the same to the concern authorized person through GSM technology. In line which is not working i.e., faulty is sensed and the information will be transmitted through GSM module automatically. This project is focused on the necessity of the automated street light system and the peculiar way of implementation with embedded system tools. The microcontroller is used as the brain to control the process involved. Relay is used as an automatic switch in this system that acts as a circuit breaker[2]. Light Dependent Resistor (LDR) is a type of sensor which actually does the work of sensing the light (line) working or not. The system with LDR sensors and GSM are used to intimate the status of light (line) ON/OFF status i.e., fault condition to the concern authorities through GSM. Through the keyboard, by entering the password, supply to that particular line can be disconnected by the line man for repairing. After repairing is done, the same line can be restored by the user himself.

**ARDUINO CONTROLLER** The Arduino Mega 2560 is a microcontroller board based on the ATmega2560. It has 54 digital input/output pins (of which 15 can be used

as PWM outputs), 16 analog inputs, 4 UARTs (hardware serial ports), a 16 MHz crystal oscillator, a USB connection, a power jack, an ICSP header, and a reset button. It contains everything needed to support the microcontroller; simply connect it to a computer with a USB cable or power it with a ACto-DC adapter or battery to get started. The Mega 2560 board is compatible with most shields designed for the Uno and the former boards Duemilanove or Diecimila. The main reason for using this is the additional features that are inbuilt with this board. First feature is the large I/O system design with inbuilt 16 analog transducers and 54 digital transducers that supports with USART and other communication modes. Secondly, it has inbuilt RTC and other features like analog comparator, advanced timer, interrupt for controller wakeup mechanism to save more power and fast speed with 16 Mhz crystal clock to get 16 MIBS. It has more than 5 pins for Vcc and Gnd to connect other devices to Arduino Mega.

**LIGHT SENSING CIRCUIT** A Light Dependent Resistor (LDR) or a photo resistor is a device whose resistivity is a function of the incident electromagnetic radiation. Hence, they are light sensitive devices. They are also called as photo conductors, photo conductive cells or simply photocells[3]. They are made up of

semiconductor materials having high resistance. A light dependent resistor works on the principle of photo conductivity. Photo conductivity is an optical phenomenon in which the materials conductivity (Hence resistivity) reduces when light is absorbed by the material.

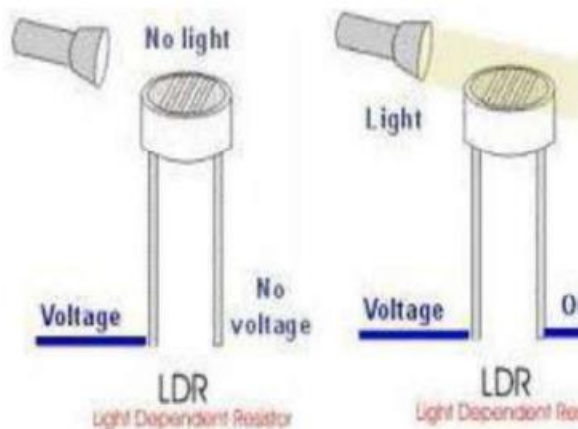

**Fig:** Light dependent Resistor

**WATER LEVEL SENSORS** A lot of varieties of water level sensors are available for us in the market with different technologies. Here in this module, the water level sensors[4] for drainage pipeline used are the common equipment generally used is the copper electrode. For identifying the level of the water in the pipe, it is equipped with two copper electrodes. One is the lowlevel indicator that is placed at 20% capability of the pipeline and the second electrode is the high-level indicator that is placed at the 90% capability of the pipeline. In addition to these two copper electrodes one more electrode is used, called as the common electrode that is given the Vcc

(supply), connected till below of the low-level indicator electrode. The outputs of these two-level sensing electrodes are connected to the microcontroller through the switching circuits designed with transistors. The outputs of the electrodes is connected to the base of the low power transistor 547, whose emitter is grounded and the collector is connected to the micro controller, which is also given supply of 5v. As water is a good conductor the copper electrodes outputs will be in high state until the tank is full in the pipeline, by which all the transistors will be in ON state and the controller will be receiving a logic high signal because the supply will be grounded through the transistor when it is in conduction. And whenever the water level decreases the electrodes will be in air and the output will be low by which the transistor will be OFF state. So the supply from the collector does not go to the controller and thus the controller receives logic low signal, so that the controller knows the water level is decreased. So when the controller gets a high signal from the 90% level electrode, automatically transmits a message through the GSM to the concern authorities. And thus the concern person will get the information about the water level of the drainage pipeline and can take necessary action to clear it early before it overflows.



**TRIGGER CIRCUIT** In this circuit IC555 timer is used as mono stable mode of configuration. The resistance of the LDR will vary from minimum to maximum according to the natural light fallen on it. The dark resistance of the LDR will be more than  $100K\Omega$  and the light resistance will be less than  $1K\Omega$ . Hence, whenever light falls on the LDR, the resistance will come down and this makes a trigger signal to the IC 555 timer. Thereby the output of the timer becomes high which is fed to the controller. During the night the resistance of the LDR will be very high by which the output of the timer remains in zero state. Depending on these high and low signals, the controller is programmed to send the information automatically through GSM to the line man mobile. The LDR will have two resistances, i.e., dark resistance and light resistance. The dark resistance is the resistance, when no light falls on the LDR. This resistance will be more than  $100K$ . The light resistance is the resistance, when light falls on the LDR i.e., if the LDR is exposed to the bright light or Sun light then the resistance of the LDR will become less than  $1K$ . The resistance of the LDR will vary according to the light intensity (Inversely proportional). This LDR is designed in association with IC 555 timer configured as 'Mono-Stable' mode of configuration. The IC 555 timer is a versatile IC, consists of

two built in comparators, threshold at  $1/3V_{cc}$  and  $2/3V_{cc}$ . The  $1/3 V_{cc}$  comparator is monitored at Pin No.2. The  $2/3 V_{cc}$  comparator is monitored at pin.6. These pins are shorted and connected to the ground through the LDR. Thus if pin no.2 voltage is less than  $1/3V_{cc}$ , output of the IC becomes high, similarly, if the voltage is more than  $2/3V_{cc}$ , output of the IC becomes zero i.e., whenever the natural light falls on the LDR, the resistance of the LDR will become less than  $1K$  and makes the voltage at Pin no. 2 or 6 less than  $1/3 V_{cc}$ , which in turn triggers the IC whose output is connected to the controller that energizes the relay. This relay contact is used to provide supply to the outdoor lights. Once the LDR resistance becomes less than  $1K$ , this in turn changes the state of internal comparator of 555 timer IC and the output of the IC to become high. This high output is fed to the controller that identifies line is working. If the output is low, then the controller understands the line is not working and will transmit a message through the GSM modem automatical

**GSM MODEM** A GSM modem is a wireless modem that works with a GSM wireless network[5]. A wireless modem behaves like a dial-up modem. The main difference between them is that a dial-up modem sends and receives data through a fixed telephone line while a wireless

modem sends and receives data through radio waves. Like a GSM mobile phone, a GSM modem requires a SIM card from a wireless carrier in order to operate AT-Command set: The following section describes the AT-Command set. The commands can be tried out by connecting a GSM modem to one of the PC's COM ports. Type in the test-command, adding CR + LF (Carriage return + Line feed = \r\n) before executing. Table gives an overview of the implemented AT-Commands in this application. The use of the commands is described in the later sections

Command	Description
AT	Check if serial interface
ATE0	Turn echo off, less traff
AT+CNMI	Display of new incomir
AT+CPMS	Selection of SMS mem
AT+CMGF	SMS string format, how
AT+CMGR	Read new message from
AT+CMGS	Send message to a give
AT+CMGD	Delete message.

Table-1: AT-Command set overview

**RELAY** A relay is an electrical switch that opens and closes under the control of another electrical circuit[6]. In the original form, the switch is operated by an electromagnet to open or close one or many sets of contacts. A relay is able to control an output circuit of higher power than the input circuit, it can be considered to be, in a broad

sense, a form of an electrical amplifier. So a relay can be defined as an automatic electromagnetic/electronic switch, which can be used to make or break the circuit

**VII) OPERATION** A relay is an electrically operated switch. Current flowing through the coil of the relay creates a magnetic field which attracts a lever and changes the switch contacts. The coil current can be on or off so relays have two switch positions and they are double throw (changeover) switches. Relays allow one circuit to switch a second circuit which can be completely separate from the first. For example, a low voltage battery circuit can use a relay to switch a 230V AC mains circuit. There is no electrical connection inside the relay between the two circuits; the link is magnetic and mechanical. The animated picture shows a working relay with its coil and switch contacts. You can see a lever on the left being attracted by magnetism when the coil is switched on. This lever moves the switch contacts.

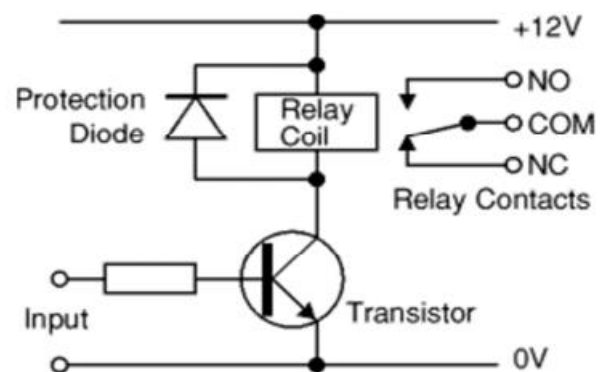

Fig: . Circuit Diagram of Relay

- COM = Common, always connect to this, it is the moving part of the switch.
- NC = Normally Closed, COM is connected to this when the relay coil is off.
- NO = Normally Open, COM is connected to this when the relay coil is on.
- Connect to COM and NO if you want the switched circuit to be on when the relay coil is on.
- Connect to COM and NC if you want the switched circuit to be on when the relay coil is off

**CONCLUSION** The project work is successfully designed tested and a demo unit is fabricated. Since it is a demonstration unit, facility is provided only for single phase line and manhole, but for real application number of sensors for individual manholes may be used depending upon the area of the field. To achieve this, the same system with enhanced technology and with required modifications can be implemented. The LDR used for sensing the natural light can be kept in a suitable glass container and it should be kept inside the manhole. This project is a cost effective, practical, eco-friendly and the safest way to save energy and this system the light status information can be accessed from anytime and anywhere. It clearly tackles the two

problems that world is facing today, saving of energy and also instant faulty light detection, very efficiently. Initial cost and maintenance can be the drawbacks of this project. With the advances in technology and good resource planning the cost of the project can be cut down and also with the use of good equipment the maintenance can also be reduced in terms of periodic checks. The LEDs have long life, emit cool light, don't have any toxic material and can be used for fast switching. For these reasons our project presents far more advantages which can over shadow the present limitations. Keeping in view the long-term benefits and the initial cost would never be a problem as the investment return time is very less. The project has scope in various other applications like for providing lighting in industries, campuses and parking lots of huge shopping malls. This can also be used for surveillance in corporate campuses and industries. In this project work the required power supply for the entire circuitry is derived from the main source, since the circuitry to be installed at roads, therefore this supply can be generated using solar energy. For this purpose, suitable solar panel can be utilized for charging the battery and the stored energy from the battery can be utilized to generate required power supply for the circuitry.



## REFERENCES

[1] Akshay Balachandran, Murali Siva, V. Parthasarathi, Surya and Shriram K. Vasudevan “An Innovation in the Field of Street Lighting System with Cost and Energy Efficiency” Indian Journal of Science and Technology, Vol-8, August 2015.

[2] A. Lay-Ekuakille, G. Vendramin, “Led-based Public Lighting System Reliability for a Reduced Impact on Environment and Energy Consumption “.

[3] Archana. G, Aishwarya N, Anitha J “Intelligent Street Light System” International Journal of Recent Advances in Engineering & Technology, Vol-3, Issue-4, 2015.

[4] Deepanshu Khandelwal, Bijo M Thomas, Kritika Mehndiratta, Nitin Kumar “Sensor Based Automatic Street Lighting system” International Journal of Education and Science Research Review Volume-2, Issue-2 April- 2015.

[5] Kapse Sagar Sudhakar<sup>1</sup>, Abhale Amol Anil<sup>2</sup>, Kudake chetan Ashok<sup>3</sup>, Shirsath Shraavan Bhaskar<sup>4</sup> “Automatic Street Light Control System” International Journal of Emerging Technology and Advanced Engineering” Volume 3, Issue 5, May 2013.

[6] R. Rubanath, T. Kavitha “GSM Based RFID Approach To Automatic Street Lighting System” 30th April 2012

[7] M. A. Wazed, N. Nafis, ‘Design and Fabrication Of Automatic Street Light Control System’, Engineering