



**ISSN: 2454-9940**



**INTERNATIONAL JOURNAL OF APPLIED  
SCIENCE ENGINEERING AND MANAGEMENT**

**E-Mail :**  
**editor.ijasem@gmail.com**  
**editor@ijasem.org**

**[www.ijasem.org](http://www.ijasem.org)**

# Speed Control Techniques of SRM

Mr.M.Giri Babu <sup>1</sup>,K.Sangeetha <sup>2</sup>, P.Umesh Chand <sup>3</sup>,

---

## Abstract: -

The speed control strategies of switching reluctance motors (SRM) were simulated using Matlab Simulink in this work. The simulation was run using three different controllers: P, PI, and PID. After some trial and error adjustment, the PID controller produced the best results in terms of settling time reduction, steady-state error removal, and speed overshoot minimization. Matlab Simulink, switching reluctance motor, PID controller, PI controller, and P controller are all part of the same dictionary.

---

## INTRODUCTION

The concept of switched reluctance motor (SRM) was established in 1838 but the motor could not realize its full potential until the modern era of power electronics and computer aided electromagnetic design. Switched reluctance motors are electrically commutated AC machines and are also known as variable reluctance motors. They are more than a high-speed stepper motor, lacking the usual expensive permanent magnets. It combines many of the desirable qualities of Inductionmotor drives, DC commutator motor drive, as well as permanent magnet (PM) brushless D.C systems. SRM is rugged and simple in construction and economical when compared with the synchronous motor and the induction motor. They are known to have high peak torque-toinertia ratios and the rotor mechanical structure is well suited for high-speed applications. In addition to this, unipolar drive of the reluctance motor is possible and therefore, the

converter requires fewer switching devices compared with the conventional inverter. From these reasons, the drive system can be more simple, economical, and reliable. It is cheap to manufacture, robust and can operate under partial failure. Its power converter has no chance for shoot through faults. The SRM show a promise as potentially low cost electromechanical energy conversion devices because of their simple mechanical construction. The advantages of switched reluctance motor are the production cost, efficiency and the torque/speed characteristics. Due to the above advantages and since SRM is becoming the competitor for induction and DC machines, this paper aims at developing better control scheme for SRM. Once the drawback of high torque ripple is reduced this motor can be effectively and successfully implemented in market for day to day life.

---

Assistant Professor <sup>1</sup>,  
Department of EEE,

---

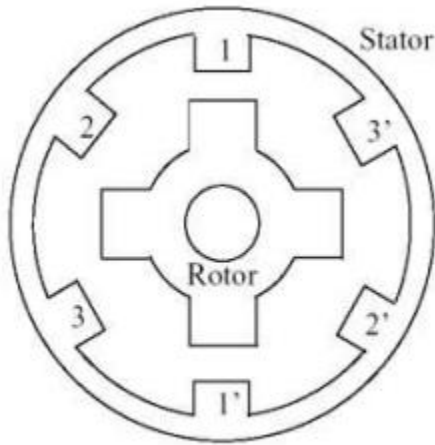
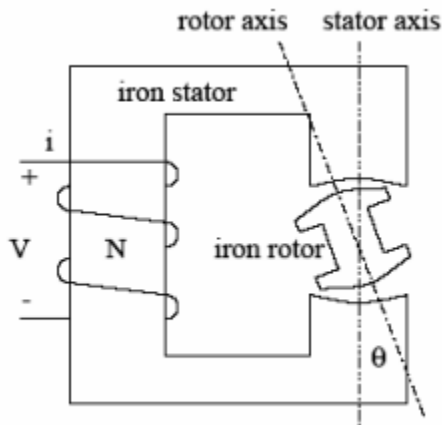

**Figure (1) Switched Reluctance Motor.**

**MATHEMATICAL MODEL OF THE SRM**

Let us consider an elementary reluctance machine as shown in Figure 2. The machine is single phase excited; that is, it carries only one winding on the

stator. The excited winding is wound on the stator and the rotor is free to rotate.



**Figure (2) Single Phase SRM.**

The flux linkage is:

$$\lambda(\theta) = L(\theta)i \dots\dots\dots (1)$$

where  $\lambda$  is the flux linkage and  $i$  is the independent input variable, (that is, the current flowing through the

stator winding). The general torque expression is given by:

$$T_e = \left[ \frac{\partial W'}{\partial \theta} \right]_{i = \text{constant}} \dots\dots\dots (2)$$

Where is the co-energy which is varying with respect to position of the rotor. At any position the co-energy is the area below the magnetization curve as shown in

Figure 3 and Figure 4. In other words, the definite integral below represents the stored magnetic energy:

$$W' = \int_0^i \lambda(\theta, i) di \dots\dots\dots (3)$$

Where  $\lambda(\theta, i)$  is the flux linkage with respect to angular position  $\theta$  and current 'i'. So the torque equation becomes:

$$T_e = \int_0^i \frac{\partial \lambda(\theta, i)}{\partial \theta} di \dots\dots\dots (4)$$

The mechanical work done is

$$\Delta W_m = \Delta W' \dots\dots\dots (5)$$

Where  $W_m$  is the mechanical energy and is the stored magnetic energy. At any rotor position  $\theta$ , the co-energy and the stored field energy are equal and is given by

$$W_f = W' = \frac{1}{2} L(\theta) i^2 \dots\dots\dots (6)$$

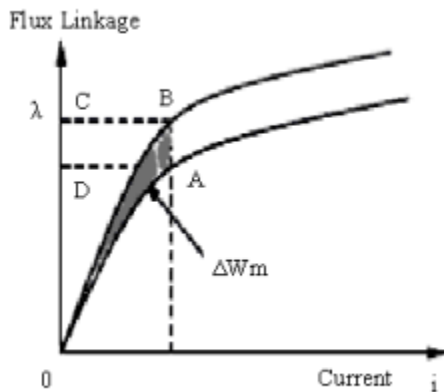

**Figure (3) Flux Linkage Chart.**

The instantaneous torque reduces to

$$T_e = \frac{1}{2} i^2 \frac{\partial L}{\partial \theta} \dots\dots\dots (7)$$

As most SRM is multiphase, the torque equation becomes a summation of torques produced by each phase. For m phases, the total torque is given by

$$T_e = \sum_{j=1}^m T_{ej} \dots\dots\dots (8)$$

Where  $T_{ej}$  is the torque due to single phase.

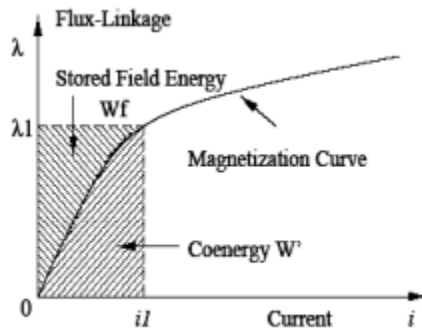
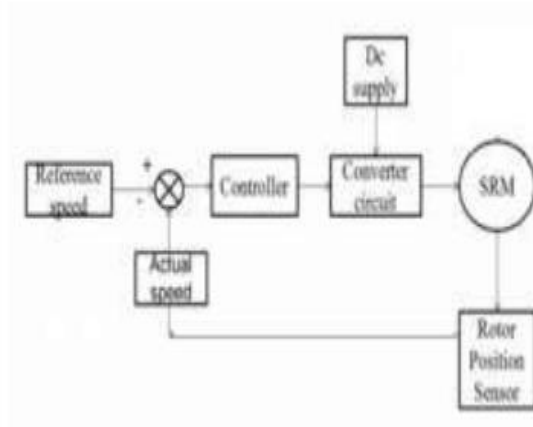

**Figure (4) Energy Exchange.**

## BLOCK DIAGRAM OF SRM CONTROL

The position of rotor is sensed by the rotor position sensor and it provides its corresponding output to the error detector. Error detector compares reference speed and actual speed to generate error signal which is given to controller block. The controller gives

appropriate control signal to the converter according to the error signal. The speed of the motor is controlled by the converter through proper excitation of the corresponding windings in the stator.



**Figure (5) Block diagram of typical SRM control scheme [4].**

Figure 6 below shows the Matlab Simulink modeling of the 6/4 SRM configuration.

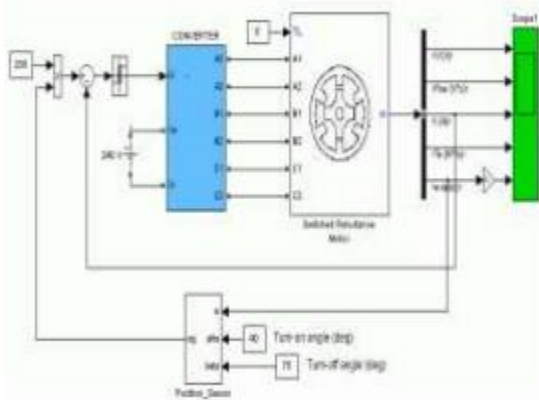

Figure (6) MATLAB Simulink modeling of 6/4 SRM

### SRM CONFIGURATIONS

Switched reluctance motors come in different configurations such as 12/8, 8/6, 6/4, and 4/2. But here, our emphasis is on 6/4 configuration. This has 3-pole pairs at the stator and 2-pole pairs at the rotor. It is also referred to as 3-phase SRM. The SRM is fed by a three-phase asymmetrical power converter having three legs, each of which consists of two IGBTs and two freewheeling diodes. During conduction periods, the active IGBTs apply positive source voltage to the stator windings to drive positive currents into the phase windings. During free-wheeling periods,

### SIMULATION OF THE 6/4 MODEL

A DC supply voltage of 240V is used. The converter turnon and turn-off angles are kept constant at 45° and 75°, respectively, over the speed ranges. The reference current is 200A and the hysteresis band is chosen as ±10A. The SRM is started by applying the step reference to the regulator input. The acceleration rate depends on the load characteristics. To shorten the

negative voltage is applied to the windings and the stored energy is returned to the power DC source through the diodes. The fall time of the currents in motor windings can be thus reduced. By using a position sensor attached to the rotor, the turn-on and turn-off angles of the motor phases can be accurately imposed. These switching angles can be used to control the developed torque waveforms. The IGBTs switching frequency is mainly determined by the hysteresis band.

starting time, a very light load is chosen. Since only the currents are controlled, the motor speed will increase according to the mechanical dynamics of the system. The SRM drive waveforms (phase voltages, magnetic flux, windings current, motor torque, and speed) are displayed on the scope as shown below.

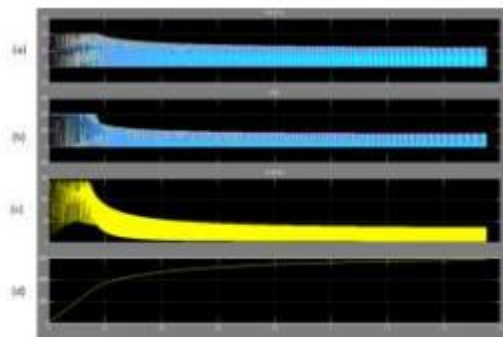

Figure 7 (a) flux, (b) current, (c) torque and (d) speed plot on the scope

As can be noted, the SRM has a very high torque ripple component which is due to the transitions of the currents from one phase to the following one. This torque ripple is a characteristic of the SRM and it depends mainly on the converter's turn-on and turn-

off angles. In observing the drive's waveforms, we can note that the SRM operation speed range can be divided into two regions according to the converter operating mode: current-controlled and voltage-fed [5].

Table (1) SRM parameters used in the Simulink model.

<b>Motor parameters</b>	<b>Values</b>
<i>Rated Power</i>	60kW
<i>Number of Phases</i>	3
<i>Number of Stator Poles</i>	6
<i>Number of Rotor Poles</i>	4
<i>Aligned Phase Inductance</i>	23.6mH
<i>Unaligned Phase Inductance</i>	0.67mH
<i>Inertia</i>	0.05Kg.m
<i>Stator Resistance</i>	0.05Ω
<i>DC Voltage Supply</i>	240V



Figure 8 block parameters for SRM

## 6. Break down of the Matlab Switched Reluctance Motor specific model

### a) Power Converter

The converter used here is an asymmetric bridge converter which switches current supplied to the phase in accordance with the rotor position.

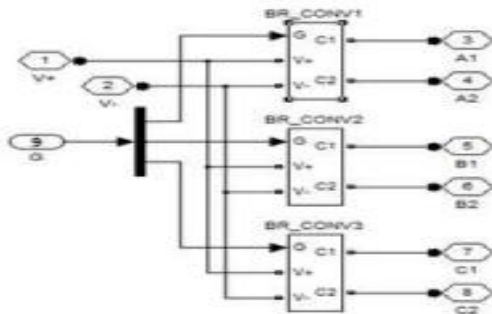

Figure (9) power converter block

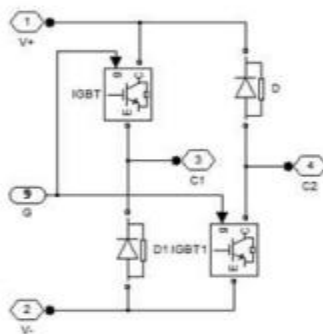

Figure (10) per phase converter, showing the switching devices

b) Position sensor

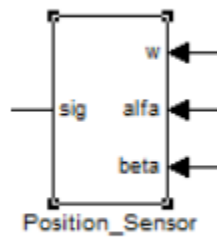

Figure (11) position sensor block

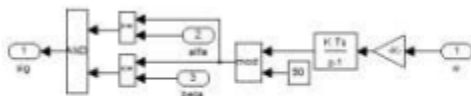

Figure (12) Inside the position sensor block

## APPLICATION OF SPEED CONTROL TECHNIQUES

Here, we take a close look at the P controller, PI controller and PID controller. The speed control is simulated on matlab and the result obtained and

analyzed. All controllers were tuned for best performance. The controller blocks are obtained from



Simulink library and incorporated into the already modeled System.

**Speed Control of SRM Using Proportional (P) Controller:**

A proportional controller system is a type of linear feedback control system. It is more complex than on-off control systems like a bi-metallic domestic thermostat, but simpler than a PID controller. In general it can be said that P controller cannot stabilize higher order processes. For the first order processes a large increase in gain can be tolerated [6]. The variation between the set points and the measured variable sets the manipulated variable in the proportional controller. If the variation is high, the manipulated variable will get affected and it cannot

stabilize higher order processes. Large gain is needed to improve the steady state error, when proportional controller is used. If proportional gain is high then the system is said to be unstable. If gain is low, it is said to be stable system. Proportional controller does not eliminate the error but reduces it. The Simulink model is designed for the speed control of switched reluctance motor using P controller. The continuous linear relationship between the output of the controller, u and the actuating error signal is

$$u = K_p e(t) \dots\dots(9)$$

Where u is the output signal, e(t) is error signal and KP is the gain constant.

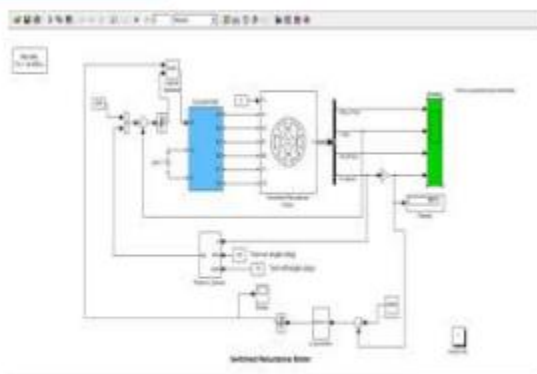

Figure (13) SRM simulink model with P controller



Figure (14) inside the P block

**Speed Control of SRM using Proportional and Integral (PI) Controller:**

It is a control feedback mechanism used in various industrial control systems. The PI controller attempts to eliminate the error which is the difference between measured variable and desired value by adjusting the process inputs. The combination of proportional and integral terms is used to increase the speed of response and to eliminate the steady state error. The output response of proportional term is equal to the current value of error. The proportional factor is adjusted by

multiplying the error value by a proportional gain which is denoted by KP. The integral term is proportional to both the magnitude and duration of the error. In PI controller, the integral term is the sum of instantaneous error over time which gives the accumulated value. Combining both terms, the relationship between the outputs from the controller to the error input is given by:

$$u = K_p e(t) + K_i \int e(t) dt \dots (10)$$

The speed of SRM is controlled by PI controller. The controller has simplicity, lowest cost, zero steady state error, ease of implementation, good speed response and robustness. It is extensively used in AC and DC drives where speed control is required. In order to

provide the desirable performance of SRM, feedback control system is employed for speed control of SRM drive. The tuned values of the PI controller constants are dependent on the system. [8]

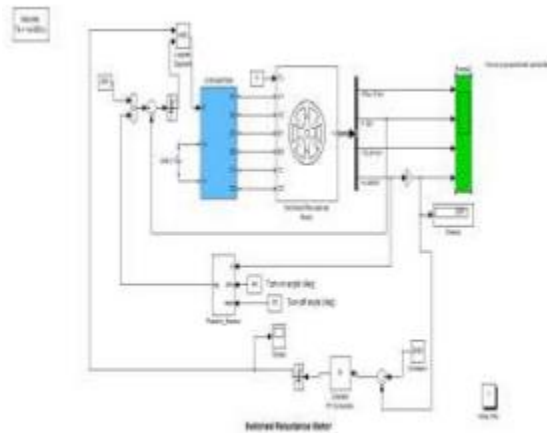

Figure (15) SRM simulink model with PI controller

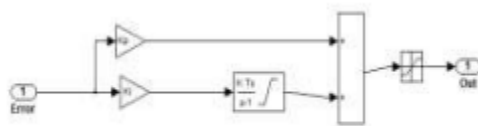

Figure (16) inside the PI controller block.

**Speed Control of SRM using Proportional, Integral and Derivative (PID) Controller:**

The relationship between the output of the controller and the error input is given by

$$u = K_p e(t) + K_i \int e(t) dt + K_d \frac{de(t)}{dt} \dots\dots\dots (11)$$

Where u is the control signal, e(t) is the error signal. The set point is called the reference variable. The proportionality constants Kp, Ki and Kd are the

parameters of the controller. The sum of the following three terms A, B, C provides control of the actuating signals.

- A) P-term (which is proportional to the error),
- B) I-term (which is proportional to the integral of the error) and
- C) D-term (which is proportional to the derivative of the error).

Proportional gain Kp, integral time constant Ti, and derivative time constant Td are the controller parameters [10]. The integral, proportional and derivative part can be interpreted as control actions

based on the past and the present. The derivative part can also be interpreted as prediction by linear extrapolation. Proportional controller is always with steady state error. The error can be decreased when the

gain is increased, obviously, the tendency towards oscillation will also get increased. When introducing integral with proportional, the strength of integral action increases with decreasing integral time  $T_i$ . The steady state error disappears on course of time when integral action is used. The oscillation increases with decreasing  $T_i$ . While introducing derivative action, the

parameters  $K_d$  and  $T_i$  are selected in such a way that the closed-loop system is continuously oscillatory. Derivative action can also be interpreted as providing prediction by linear extrapolation over the time  $T_d$ . Figure 17 shows the MATLAB model of PID controller designed specifically for the SRM machine and figure 18 shows the PID Controller block.

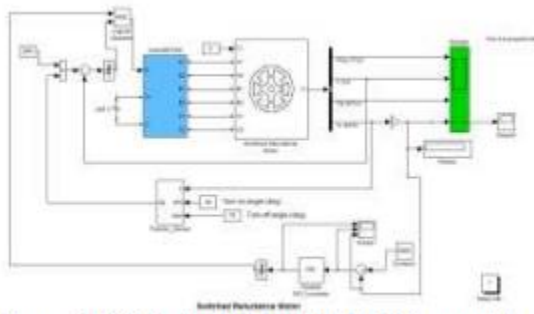

Figure (17) SRM simulink model with PID controller

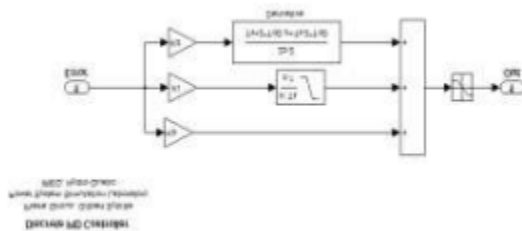

Figure (18) inside the PID controller block

### Determining $K_P$ , $K_i$ and $K_d$

The control signal is always proportional to the error signal and the proportional gain  $K_P$  using a proportional controller. It will also have the effect of reducing the rise time and error but never eliminates error. Integral control will have the effect of reducing error, in principle, to zero value while derivative control is used to anticipate the future behavior of the error signal by using corrective actions based on the rate of change in the error signal. The control signal is proportional to the derivative of the error and  $K_d$  is the derivative gain.

Derivative control will have the effect of increasing the stability of the system, reducing the overshoot, and

improving the transient response. Derivative control action can never be used alone because this control action is effective only during transient periods. The PID controller makes a control loop respond faster with less overshoot and it is the most popular method of control by a great margin. The combined action has the advantages of each of the three individual control actions. Stator resistance is 0.05ohms and inertia of the motor 0.05Kg/m<sup>2</sup>. The value of the constants of the controller  $K_P$ ,  $K_i$  and  $K_d$  is dependent on the system to be controlled, so after tuning appropriately and testing for best condition, the values of the constant used for this analysis was obtained as follows:

For P controller,  $K_p = 50$

For PI controller,  $K_p = 50, K_i = 0.1$

For PID controller,  $K_p = 20, K_i = 0.1, K_d = 0.05$

The reference speed was set at 1000rpm, 2000rpm and 3000rpm and resulting response is displayed in the scope. The graph displayed on the scope is speed against time. Increasing the reference speed, it is observed from the scope plot that the settling time increases. Figure 19 to figure 24 show the speed response for a P controller, and figure 25 to figure 30 show the speed response for a PI controller and figure 31 to figure 36 show the speed response for a PID controller for a no load operation of the SRM. It is

observed from the scope that with P controller we experience speed overshoot and oscillation before settling at the reference value. This overshoot still remains with the PI controller but is eliminated with the PID controller after proper tuning. The settling time is least with the PID controller and the steady state error is eliminated. The simulation was also extended to a condition of a load of 5 Nm. The overall results are as shown in table 3.

**Table (2) Comparison of Gain Response of P, PI and PID controller [9]**

Parameter	Speed of response	Stability	Accuracy
Increasing $K_p$	Increase	Deteriorate	Improves
Increasing $K_i$	Decreases	Deteriorate	Improves
Increasing $K_d$	Increases	Improves	No impact

### 1. P controller output

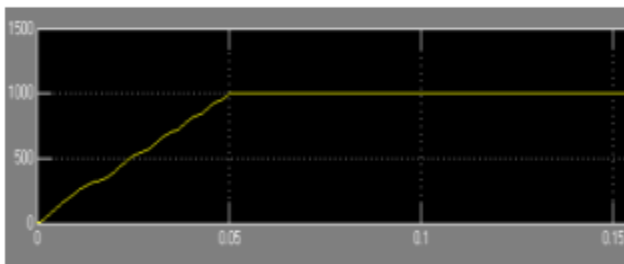

*Figure (19) speed response of SRM with P controller for 1000rpm on no load*

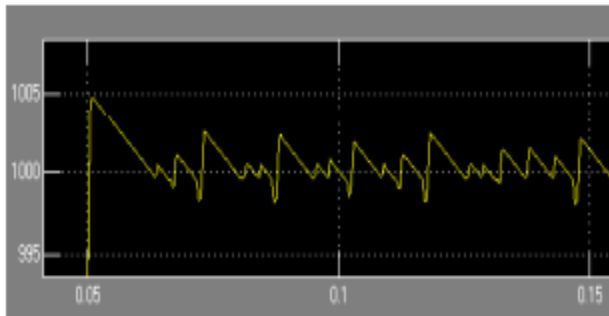

Figure (20) Zoomed speed response of SRM with P controller for 1000rpm on no load showing overshoot

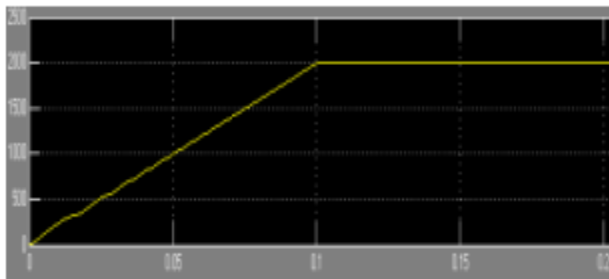

Figure (21) speed response of SRM with P controller for 2000rpm on no load

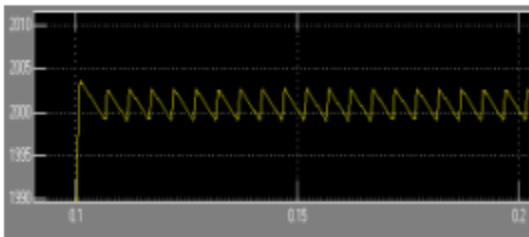

Figure (22) Zoomed speed response of SRM with P controller for 2000rpm on no load showing overshoot

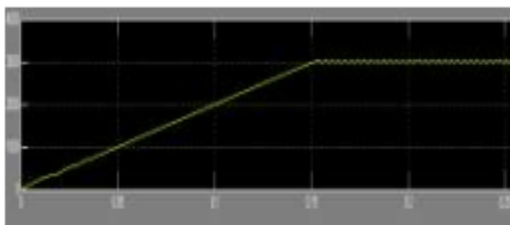
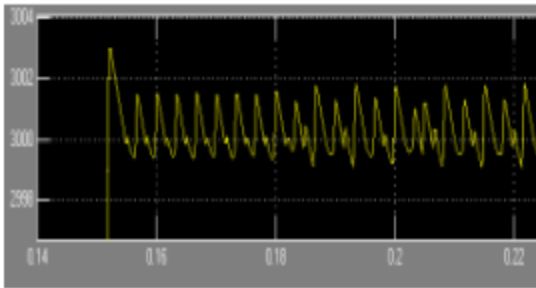
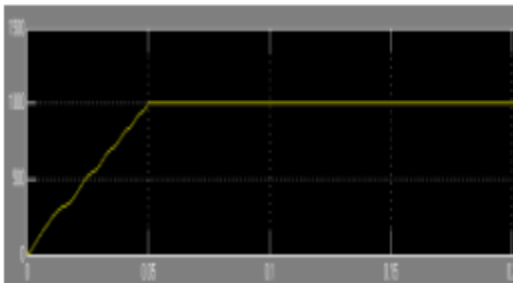

Figure (23) speed response of SRM with P controller for 3000rpm on no load



*Figure (24) Zoomed speed response of SRM with P controller for 3000rpm on no load showing overshoot*

## 2. PI controller output



*Figure (25) speed response of SRM with PI controller for 1000rpm on no load*

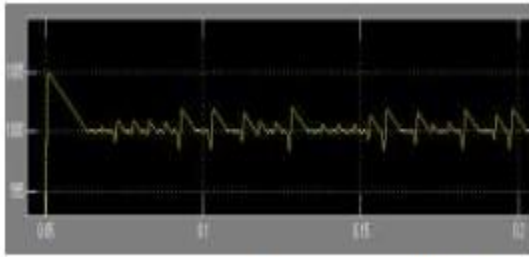

Figure (26) Zoomed speed response of SRM with PI controller for 1000rpm on no load showing overshoot

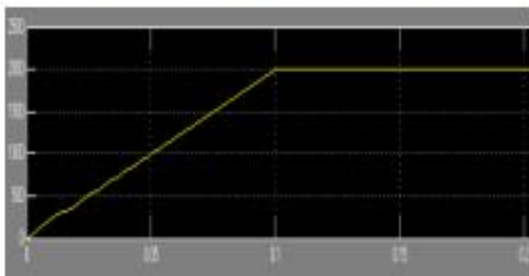

Figure (27) speed response of SRM with PI controller for 2000rpm on no load

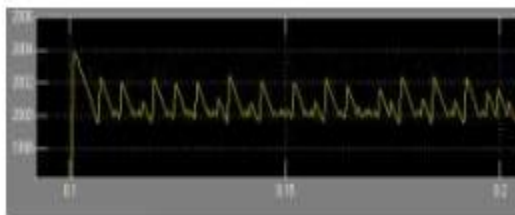

Figure (28) Zoomed speed response of SRM with PI controller for 2000rpm on no load showing overshoot

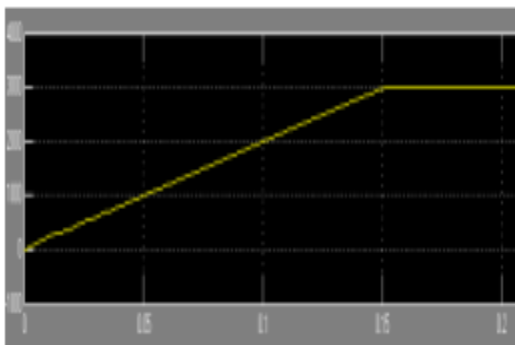

Figure (29) speed response of SRM with PI controller for 3000rpm on no load

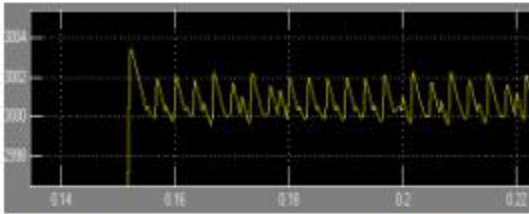

Figure (30) Zoomed speed response of SRM with PI controller for 3000rpm on no load showing overshoot

### 3. PID controller outputs

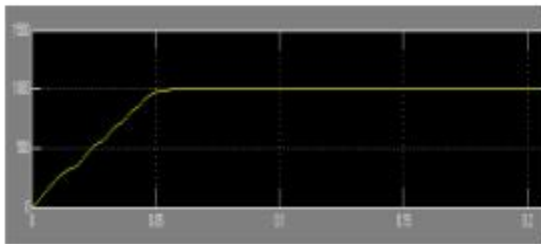

Figure (31) speed response of SRM with PID controller for 1000rpm on no load

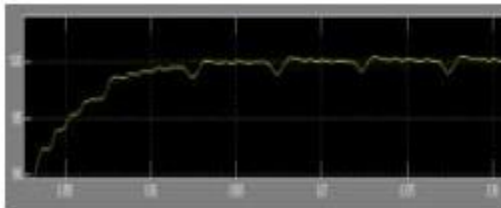

Figure (32) zoomed view of the speed response of PID controller for 1000rpm



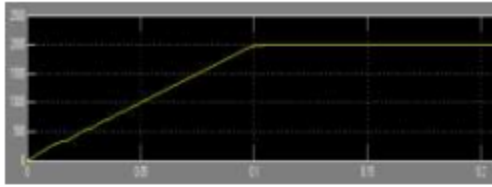

Figure (33) speed response of SRM with PID controller for 2000rpm on no load

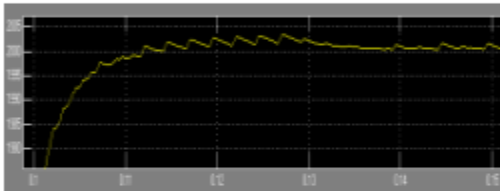

Figure (34) zoomed view of the speed response of PID controller for 2000rpm

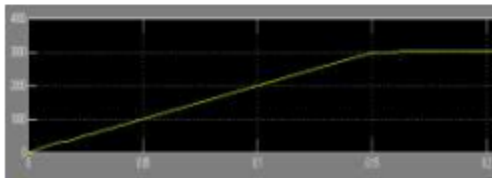

Figure (35) speed response of SRM with PID controller for 3000rpm on no load

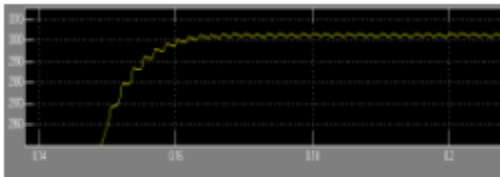

Figure (36) zoomed view of the speed response of PID controller for 3000rpm

**Table (3) Representation of the result of the simulation.**

a) P controller,  $K_p = 50$

Speed (rpm)	Settling time $T_s$ (sec)		Peak Overshoot (rpm)	
	No load	$T_L = 5Nm$	No load	$T_L = 5Nm$
1000	0.063	0.060	1005	1003
2000	0.108	0.109	2004	2003
3000	0.156	0.160	3003	3003

b) PI controller,  $K_p = 50, K_i = 0.1$

Speed (rpm)	Settling time $T_s$ (sec)		Peak Overshoot (rpm)	
	No load	$T_L = 5Nm$	No load	$T_L = 5Nm$
1000	0.063	0.058	1005	1003
2000	0.106	0.108	2003	2005
3000	0.156	0.161	3004	3003

c) PID controller,  $K_p = 20, K_i = 0.1, K_d = 0.05$

Speed (rpm)	Settling time $T_s$ (sec)		Peak Overshoot (rpm)	
	No load	$T_L = 5Nm$	No load	$T_L = 5Nm$
1000	0.051	0.054	1001	1000
2000	0.102	0.107	2001	2000
3000	0.152	0.157	3002	3001

P controller has high peak overshoot and quite long settling time. For PI controller, overshoot value increased and the settling time increased as well. At last, the PID controller has lowest settling time and lowest overshoot. So PID is the most suitable for speed control out of the three kinds of controllers analyzed here under load and no load conditions. The reduction in the settling time becomes more pronounced when

## CONCLUSION

In contrast to commutation motors, 6/4 switching reluctance motors are easy to build and operate because to their asymmetric bridge converter drive. The SRM was optimized for performance via

the speed is as high as 50,000rpm or more. Thus, this study has proved the superiority of the PID controller over the rest as presented here. This is in terms of elimination of speed overshoot, elimination of steady-state error as well as in reduction of the settling time as the motor speed moves from zero to the reference speed.

simulation using the Simulink model. When testing for settling time, speed overshoot, and steady-state inaccuracy, the PID controller performed the best.

## REFERENCES

[1]

W.R. Ray. P.J. Lawrenson, RM. Davis. LM. Stephenson, N.N. Fulton and R.J. Blake, Wigh "performance switched reluctance brushless drives", *IEEE IAS Annual Meeting Conference Record*, pp. 1769-1776. 1985

[2] J.M. Stephenson, S . R Mac Minn, and J.R. Henderson Jr.. "Switched Reluctance Drives", *IEEE IAS 1990*

[3] Ramya A, Dhivya G, Bharathi PD, Dhyaneswaran R, Ramakrishnan P. "Comparative study of speed control of 8/6 switched reluctance motor using pi and fuzzy logic controller". *IJRTE*; 2012

[4] A.Jeevanandham and K.Thanushkodi, "Reduction of Generator Rotor Oscillations using a Meta-heuristic Optimization Technique," *International Journal of Systemics, Cybernetics and Informatics, India, ISSN 0973 -4864, No.9, 2008, pp.54-60.*

[5] mathwork.com

[6] Wadah Abass Aljaism," SWITCHED RELUCTANCE MOTOR: DESIGN, SIMULATION AND CONTROL". School of Engineering DRG

"Power Conversion and Intelligent Motion Control" University of Western Sydney.

[7] A.Jeevanandham and K.Thanushkodi, "Reduction of Generator Rotor Oscillations using a Meta-heuristic Optimization Technique," *International Journal of Systemics, Cybernetics and Informatics, India, ISSN 0973 -4864, No.9, 2008, pp.54-60.*

[8] Muthulakshmi S. and Dhanasekaran R, "Performance Evaluation In Speed Control Of Classic Converter Fed Switched Reluctance Motor Using Pi Controller". *ARPN Journal of Engineering and Applied Sciences VOL. 10, NO. 6, APRIL 2015 ISSN 1819-6608*

[9] K Smriti Rao, 2Ravi Mishra, "Comparative study of P, PI and PID controller for speed control of VSI-fed induction motor". 2014 *IJEDR | Volume 2, Issue 2 | ISSN: 2321 -9939 1*

[10] Sridharan, S.I and Sudha,S.vPak, "Real time implementation of Pid Controller for Switched Reluctance Motor". Vol. 13 (special issue on Innovations in information Embedded and communication Systems) Pp. 533- 537 (2016) 53