



ISSN: 2454-9940



**INTERNATIONAL JOURNAL OF APPLIED
SCIENCE ENGINEERING AND MANAGEMENT**

E-Mail :
editor.ijasem@gmail.com
editor@ijasem.org

www.ijasem.org

ADVANCED CENTRALIZED RTO SYSTEM

DR.S.SATISH¹, G.SRI HARSHINI², K.SUKESHINI³, G.V.THANUJA⁴

Article Info

Received: 07-07-2022

Revised: 14-08-2022

Accepted: 24-09-2022

ABSTRACT - The current RTO system for vehicle registration includes numerous stages with tremendous man-power. In current system, there is no privilege for online registration of vehicle. So in that case every user must visit RTO office multiple times for registration. It takes more time to register the vehicle. Also, in tollbooth system user has to spend time for toll payment because current system is manual. In this system more manpower is used for toll collection and traffic management. As the number of vehicles increases, the system need to be automated. We can optimize the whole process using automation. This document describes the project of SMART RTO SYSTEM in which we are providing centralized database. The database stores all the information related to owner and his/her vehicle. In this project we are providing account control with different roles to different users. Each user can sign up in the system by filling his/her personal details. In sign up process, user is verified using OTP. With the help of created account, user can register a vehicle using vehicle registration form. Then user can schedule for appointment for verification by authorized person at RTO. RTO officer will have to verify user details and vehicle details in scheduled appointment. Once verified, officer will assign GPS ID, RFID and vehicle number and save it in the database. Authenticated user profile will contain e-wallet for toll payment. We can automate the toll payment process by using RFID given to each vehicle. By using IOT we can identify particular vehicle and access its data from database using RFID and GPS ID. After identifying vehicle at toll plaza, toll amount is deducted from respective user's wallet. For query solution we are going to implement chat bot. Graphical representation of toll plaza activity is shown to the toll controller with the help of Power BI.

KEYWORDS: Vehicle Registration, Tollbooth, Automated, Smart RTO, Centralized Database, Account Control, OTP, GPS ID, RFID, E-wallet, IoT, Chat bot, Power bi

INTRODUCTION

Vehicle management is one of the primary problem that developing countries are facing. The main issue in the vehicle management is that when new vehicle is registered then there is no centralised database that saves the whole information of vehicle and owner. Problem: The current system includes the database which stores vehicle information but it is not centralised hence toll management system cannot access this data [1]. So toll automation [2] is not present in current system. More man-power engaged in current system. The system is manual hence time and money increased. As the population increases in developing country like

PROFESSOR¹, UG SCHOLAR^{2,3&4}

DEPARTMENT OF ECE, MALLA REDDY ENGINEERING COLLEGE FOR WOMEN (UGC-AUTONOMOUS)
MAISAMMAGUDA, HYDERABAD-500100

India, the number of vehicles also increases which results in overload on current RTO and toll plaza system. According to survey, India's population was 1.324 billion (2016) is projected to grow up to 8.6 billion by 2030. This count of population is directly proportional to the number of vehicles being sold. If we consider only Maharashtra, there are approx. 23.4 million vehicles. The total number of registered motor vehicles in Maharashtra State, increased from 3,07,030 as on 31st. March, 1971 to 2,78,69,866 as on 31st. March, 2016. And 50 RTO offices are currently active in Maharashtra. As the RTO and toll process is manual, it is difficult to handle such huge count of vehicles. At each toll on an average 20000 vehicles pay the toll. For each vehicle at least 3 min. of time is required. Hence long traffic queue is formed. The system is manual hence it is difficult to handle the process.

SOLUTION We can automate this process by assigning RFID and GPS id to each vehicle and by online process we can register vehicles and manage central database. By using this automated system, manpower, time, money will be reduced. Hence at each toll plaza due to system is automated time required for each vehicle reduces to few seconds. Each vehicle having GPS associated with it, so tracking of vehicle become easy [3]. For query solution we are going to implement chat bot [4]. Graphical representation of toll

plaza activity is shown to the toll controller with the help of Power BI [5].

MOTIVATION As the population increases, the vehicles will in turn increase. Due to increase in vehicles traffic on road and load on toll plaza increases. We can automate these system by online registering [6] the vehicle and by calculating toll automatically [2]. We can also save manpower, locate the vehicle using GPS ID and save each vehicle information at global storage. Also this automation system plays important role in efficient traffic management.

OBJECTIVE Main objective of the system is to reduce the wastage of manpower and to auto-mate the whole process of vehicle registration and toll management [2]. This would reduce multiple trips to go to RTO office and waiting time in queues for toll payment. In the proposed system we will be developing a smart RTO system which will register new vehicle and assign RFID, GPS ID and registration number. RFID is used to automate the toll booth system [3]. Location of the particular vehicle can be found out using GPS ID.

SCOPE For initial stage, username and password [7] is to be given as input to the application software for the purpose of logging in the user.

- ✚ Once the login is successful [8], user can fill up his personal details, vehicle information and schedule for appointment.
- ✚ On the appointment date, verification against documents will be done and RFID, GPS ID is assigned to the vehicle. Thus the user is authenticated by RTO officer. These all information is stored in central database
- ✚ When the vehicle is at toll, IOT system captures RFID and information associated with that RFID is retrieved.
- ✚ Toll is deducted from the e-wallet [9] of associated user account automatically. Major input: Login Credentials and vehicle information.
- ✚ Output: Status of user application and e-wallet transactions [10].

GOAL

- ✚ Account control with different roles to different users and user will be able to register new vehicle with its personal information.
- ✚ To reduce manual work.

- ✚ To manage the registration and monitoring of vehicles.

LITERATURE SURVEY

STEVEN GIANVECCHIO, MENGJUN XIE, MEMBER, IEEE, ZHENYU WU, AND HAINING WANG, SENIOR MEMBER, IEEE " HUMANS AND BOTS IN INTERNET CHAT: MEASUREMENT, ANALYSIS, AND AUTOMATED CLASSIFICATION "IEEE/ACM TRANSACTIONS ON NETWORKING, VOL. 19, NO. 5, OCTOBER 2011 AND BOTS IN INTERNET CHAT. [5]

Description: Proposed system which consists of two components:

- 1) an entropy-based classifier and
- 2) a Bayesian-based classifier.

Advantages: 1) An entropy-based classifier is more accurate to detect chat bots. 2) Bayesian based classifier is faster to detect known chat bots. 3) System is highly effective in differentiating chat bots from humans. 4) Accuracy and goodspeed.

Disadvantages: 1) Not suitable for messages which are small in size or shorter messages. 2) Cannot identify whether the message is generated by bot or human.

**EDDY PRASETYO NUGROHO,
RIZKY RACHMAN JUDHIE PUTRA,
IMAN MUHAMAD RAMADHAN
DEPARTMENT OF COMPUTER
SCIENCE EDUCATION, FACULTY
OF MATHEMATICS AND NATURAL
SCIENCES EDUCATION INDONESIA
UNIVERSITY OF EDUCATION
BANDUNG, WEST JAVA,
INDONESIA, 40154 "SMS
AUTHENTICATION CODE
GENERATED BY ADVANCE
ENCRYPTION STANDARD (AES) 256
BITS MODIFICATION ALGORITHM
AND ONE TIME PASSWORD (OTP)
TO ACTIVATE NEW APPLICANT
ACCOUNT"2016 2ND
INTERNATIONAL CONFERENCE
ON SCIENCE IN INFORMATION
TECHNOLOGY (ICSITECH). [7]**

Description: This describes the way to enhance security measures in registration process by generating authentication code to verify and activate the account.

Advantages: 1) Authentication code is generated through activation message. 2) Activation message is encrypted using Advanced Encryption Standard (AES). 3) Provides enhanced security measures. 4) Detect fake accounts and avoids creating of fake accounts.

Disadvantages: 1) The algorithm takes more time to execute. 2) As it contains key combination it takes longer time to decrypt the message

**SILKE HOLTMANNS ,IAN OLIVER
"SMS AND ONE-TIME PASSWORD
INTERCEPTION IN LTE
NETWORKS"IEEE ICC 2017
COMMUNICATION AND
INFORMATION SYSTEMS
SECURITY SYMPOSIUM. [8]**

Description: Network providers are now moving towards diameter based LTE networks with hope that the additional security provided in the protocol also improves overall interconnection security.

Advantages: 1) SS7 protocol provides additional security. 2) Improved overall interconnection security.

Disadvantages: 1) OTP generated can be intercepted by an intrusion

**PROF. CHANDRAKANT UMARANI1,
RASHMITEGGI2, PRACHI SHETTI3,
LAVANYA DODAMANI4, YOGITA
HAVALE5 ASSISTANT
PROFESSOR1, STUDENT2, 3, 4, 5
"SMART RTO WEB AND ANDROID
APPLICATION" INTERNATIONAL
JOURNAL OF ENGINEERING
SCIENCE AND COMPUTING, JUNE
2017.[6]**

Description: By storing all the information related to vehicle and driver at database by RTO administrator. And android application is provided to traffic police to retrieve vehicle and license information.

Advantages: 1) Eliminates human interaction. 2) Auto generation of challan and amount of penalty. 3) It is very time efficient. 4) It also saves paper because all data are in digital format.

Disadvantages: 1) There is possibility of humans becoming lazy.

RAMA B. TAKBHATE AND PROF S.D CHAVAN "AUTOMATED TOLL BOOTH SYSTEM" INTERNATIONAL JOURNAL OF RESEARCH STUDIES IN COMPUTER SCIENCE AND ENGINEERING (IJRSCSE) VOLUME. 1, ISSUE 3, JULY 2014, PP 69- 76 ISSN 2349-4840 (PRINT) & ISSN 2349-4859(ONLINE). [2]

Description: This document examines the image of the number plate and class of vehicle, the respective information will be processed for toll collection system, to make more efficient and perfect.

Advantages: 1) No need human interaction. 2) No or shorter queues at toll plazas by increasing toll booth service turnaround rates. 3) Faster and more

efficient service. 4) No need to request for receipts **Disadvantages:** 1) Requires best quality cameras as image processing requires best quality of image captured by camera. 2) Algorithm used for image processing is complex and inefficient.

SALTO MARTÍNEZ RODRIGO, JACQUES GARCÍA FAUSTO ABRAHAM "DEVELOPMENT AND IMPLEMENTATION OF A CHAT BOT IN A SOCIAL NETWORK" 978-0-7695-4654-4/12 \$26.00 © 2012 IEEE DOI 10.1109/ITNG.2012.14. [4]

Description: This describes how to implement a Chat Bot on Twitter social network for entertainment and viral advertising using database and a simple algorithm.

Advantages: 1) Message processing is fast. 2) Messages are divided into words and phrase for classification.

Disadvantages: 1) Inefficient to handle grammatical errors. 2) Unable to identify message generated by bot.

EXISTING SYSTEM APPROACH

Existing system Disadvantage

- There is no centralised database that saves the whole information of vehicle and owner.

- Toll automation is not present in current system.
- GPS module is not implemented in current vehicles to track them.

PROPOSED SYSTEM

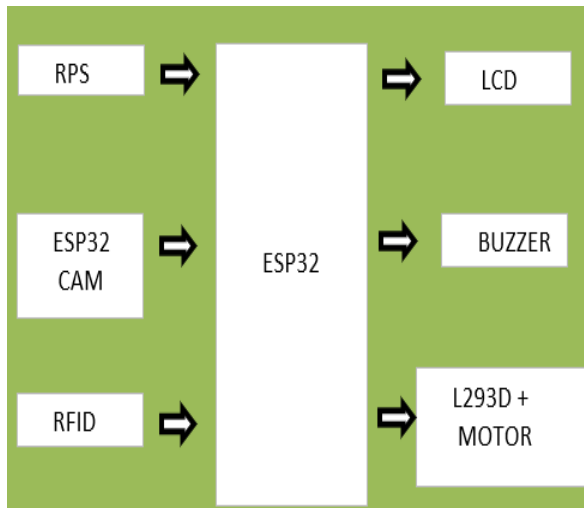

The current RTO system for vehicle registration includes numerous stages with tremendous man-power. In current system, there is no privilege for online registration of vehicle. So in that case every user must visit RTO office multiple times for registration. It takes more time to register the vehicle. Also, in tollbooth system user has to spend time for toll payment because current system is manual. In this system more manpower is used for toll collection and traffic management. As the number of vehicles increases, the system need to be automated.

CONCLUSION

The current system for vehicle registration includes numerous stages with tremendous manpower. In current system there is no privilege for online registration of vehicles. Also, in tollbooth system more man power is used for toll collection and traffic management at toll plaza. In proposed system whole process is automated and optimized. Parsons's personal information and vehicle information is stored at central database. As we have integrated RFID and GPS ID with each and every vehicle we can easily identify and locate the specific vehicle. Due to RFID we have automated tollbooth system. It saves time, reduces traffic and minimizes the fuel consumption during idle condition of the vehicle. It can be used to remove drawbacks of current systemsuch as time and human efforts.

REFERENCES

- [1] Mishra Avnish, Singh Ashish, Singh Rajeshwar "Smart RTO System (SRS)", International Journal of Advance Research, Ideas and Innovations in Technology, Volume3, Issue2, PP:675-681,2017.
- [2] Rama B. Takbhate and Prof S.D Chavan "Automated Toll Booth System" International Journal of Research Studies in Computer Science and Engineering

(IJRSCSE) Volume. 1, Issue 3, PP 69-76, July 2014.

[3] Arokianathan P , Dinesh V , Elamaram B , Veluchamy M and Sivakumar S "Automated Toll Booth and Theft Detection System " 2017 IEEE International Conference on Technological Innovations in ICT For Agriculture and Rural Development,978-1-5090-4437-5/17, 2017.

[4] Salto Martínez Rodrigo, Jacques García Fausto Abraham, "Development and Implementation of a Chat Bot in a Social Network",IEEE Ninth International Conference on Information Technology,978-0-7695-4654-4/12, PP: 751-755,2012.

[5] Steven Gianvecchio, MengjunXie, Member, IEEE, Zhenyu Wu, and Haining Wang, Senior Member, IEEE " Humansand Bots in Internet Chat: Measurement, Analysis, and Automated Classification "IEEE/ACM TRANSACTIONS ON NETWORKING, VOL. 19, NO. 5, OCTOBER 2011.

[6] Prof. ChandrakantUmarani, RashmiTeggi, PrachiShetti, LavanyaDodamani, YogitaHavale, "Smart

RTO Web and Android Application", International Journal of Engineering Science and Computing, Volume 7, Issue 6, June 2017.

[7] Eddy PrasetyoNugroho, RizkyRachmanJudhie Putra, ImanMuhamad Ramadhan, "SMS Authentication Code Generated by Advance Encryption Standard (AES) 256 bits Modification Algorithm and One Time Password (OTP) to Activate New Applicant Account", 978-1- 5090-1721- 8/16, 2016.

[8] SilkeHoltmanns ,Ian Oliver, "SMS and One-Time Password Interception in LTE Networks", IEEE ICC Communication and Information Systems Security Symposium, 978-1-4673-8999-0/17, 2017.

[9] EligijusSakalauskas, Jonas Muleravicius, Inga Timofejeva, "Computation Resources for Mobile E-Wallet System With Observers", IEEE, 978-1-5386-0394-9/17, 2017.

[10] BehzadYahid, Dr. Mohammad BagherNobakht, "Providing Security for E-wallet using E-cheque", IEEE 7th International Conference, 978- 1-4799-0393-1/13, 2013.