



ISSN: 2454-9940



**INTERNATIONAL JOURNAL OF APPLIED
SCIENCE ENGINEERING AND MANAGEMENT**

E-Mail :
editor.ijasem@gmail.com
editor@ijasem.org

www.ijasem.org

DUAL AXIS SOLAR TRACKER

A.Vaani¹,P.Jyoti²,

ABSTRACT

Abstract- As population is increasing globally; we are very concerned for Electricity. There are various ways of electricity generation like Hydro power plant, Nuclear power plant, Windmill plants and also Solar power plants. The former two are Non Renewable source of energy; hence we cannot depend only on such technology. Also Harnessing Energy from Hydro and Nuclear is equally difficult. The latter two are Renewable source of Energy; nowadays we have lots of power plants established on Solar and Wind Technology. Our project aims at Dual axis or Dual direction tracker. The Solar panel used in this system can adjust its direction both in X-Y co-ordinates. This helps better directivity with Sun rays, thus increasing the efficiency of the solar system.

Keywords- Dual Axis, Stepper Motor, LDR Sensors, Declination Angle

INTRODUCTION

Electrical energy from solar panels is derived by converting energy from the sun rays into electrical current. The main challenge is to maximize the capture of the sun rays upon the solar panels, which in turn maximizes the output of electricity. There are two possible ways to enhance output power from solar energy based systems. Either one can use an efficient material in the manufacturing of the photo voltaic cell or use a solar tracker to follow the sun. Why is it practically possible to install solar panel in India? The Earth is an oblate spheroid, meaning that it is a sphere that is flattened at the poles and bulges around the equator. For solar power calculations it is sufficient to consider the Earth as a simple sphere with a diameter of approximately 12800km. Points on the Earth's surface are defined in terms of longitude and latitude. The Earth rotates around its axis every 24

hours and orbits the sun every 365.25 days (Approximately). The axis of rotation is tilted at an angle of 23.45° with respect to the plane of the orbit around the Sun. The axis is orientated so that it always points towards the Pole Star. This accounts for the seasons and changes in the length of day throughout the year. The angle between a line joining the centers of the Sun and the Earth and the equatorial plane is called the declination angle (δ). Because the axis of the Earth's rotation is always pointing to the Pole Star the declination angle changes as the Earth orbits the Sun [3]. India lies in the Tropic of Cancer region. This makes it practically possible for implementing solar panel in our country compared to the countries located beyond 23.45° . The dual-axis solar tracker tracks the angular height position of the sun in addition to following the sun's east-west movement. The dual-axis works similar to single axis but it captures the solar energy more effectively by rotating its axis along vertical and horizontal axis [1]

*Professor¹, Assistant Professor²
Department of ECE Engineering,
Pallavi Engineering College,
Mail.id: ec_vaani@pallaviengineeringcollege.ac.in, Mail ID: ecejyoti.pallavi@gmail.com,
Kuntloor(V), Hayathnagar(M), Hyderabad, R.R. Dist.-501505.*

EMBEDDED SYSTEM:

An embedded system is combination of computer hardware and software. Embedded system is designed for a specific function or for specific functions within a larger system. Industrial machines, agricultural and process industry devices, automobiles, medical equipment, cameras, household appliances, airplanes, vending machines and toys as well as mobile devices are all possible locations for an embedded system.

Example R &D why lap top is not an embedded system:

An embedded system can be considered as a system with which we cannot develop anything. Example with the help of washing machine we can wash the clothes only. Using microwave oven we will heat the products only. But general purpose systems we developed some thing. For example using laptop we develop the various applications. Example using MS office we can create word files.

Note: olden days mobile phone used for dedicated application. Hence it is a embedded system. Now a days smart phones performs various tasks so smart phones are treated as 'general purposesystems.

CLASIFICATION OF EMBEDDED SYSTEM:

Based on performance, functionality, requirement the embedded systems are divided into three categories: Standalone systems embedded: These systems takes the input in the form of electrical signals from transducers or commands from human beings such as pressing of a button etc., process them and produces desired output. This entire process of taking input, processing it and giving output is done in standalone mode. Such embedded systems comes under standalone embedded systems

Example: microwave oven, air conditioner etc.,

Soft real time embedded systems: These embedded systems follow a relative dead line timeperiod i.e., if

the task is not done in a particular time that will not cause damage to the equipment.



Fig: TV with Remote

Example: Consider a TV remote control system, if the remote control takes a few milliseconds delay it will not cause damage either to the TV or to the remote control. The systems that will not cause damage when they are not operated at considerable time period those systems comes under soft real-time embedded systems. Real-time embedded systems: Embedded systems that are used to perform a specific task or operation in a specific time period those systems are called as real-time embedded systems. Network communication embedded systems: A wide range network interfacing communication is provided by using embedded systems. consider a web camera that is connected to the computer with internet can be used to spread communication like sending pictures, images, videos etc., to another computer with internet connection throughout anywhere in the world. Consider a web camera that is connected at the door lock. Whenever a person comes near the door, it captures the image of a person and sends to the desktop of your computer which is connected to internet. This gives an alerting message with image on to the desktop of your computer, and then you can open the door lock just by clicking the mouse.



Fig: Network Communication Embedded System

EXMPL E OF EMBEDDED SYSTEM:

A Micro controller consists of a powerful CPU tightly coupled with memory, various I/O interfaces such as serial port, parallel port timer or counter, interrupt controller, data acquisition interfaces-Analog to Digital converter, Digital to Analog converter, integrated on to a single siliconchip.

Microcontrollers are dedicated for specific applications. A microcontroller may take an input from devices like sensors and displays the output or controls the output devices like fans, motors or doing both of them shown below.

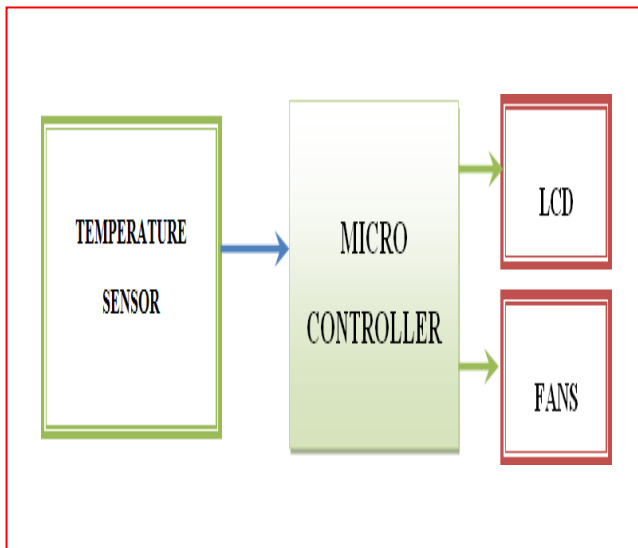

Fig: application of microcontroller

The Temperature sensor that can be used to measure temperature with an electrical output proportional to the temperature (in °C). Example: LM35 - An Integrated Circuit Temperature Sensor can be used to

measure temperature with an electrical output proportional to the temperature (in °C). The Micro controller takes input from the external sources and routes them to the appropriate devices as programmed in it. The LCD displays the temperature value. Moreover, depending upon temperature the microcontroller controls the fan like On/Off.

Overview of Embedded System Architecture

Every embedded system consists of custom-built hardware built around a Central Processing Unit (CPU). This hardware also contains memory chips onto which the software is loaded. The software residing on the memory chip is also called the ‘firmware’. The embedded system architecture can be represented as a layered architecture as shown in Fig.

Fig: Layered architecture of Embedded System

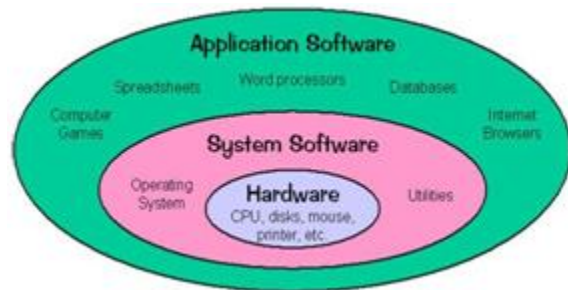

The operating system runs above the hardware, and the application software runs above the operating system. The same architecture is applicable to any computer including a desktop computer. However, there are significant differences. It is not compulsory to have an operating system in every embedded system. For small appliances such as remote control units, air conditioners, toys etc., there is no need for an operating system and you can write only the software specific to that application. For applications involving complex processing, it is advisable to have an operating system. In such a case, you need to integrate the application software with the operating system and then transfer the entire software on to the memory chip. Once the software is transferred to the memory chip, the software will continue to run for a long time you don't need to reload new software.

Now, let us see the details of the various building blocks of the hardware of an embedded system. As shown in Fig. the building blocks are;

Central Processing Unit (CPU)

Memory (Read-only Memory and Random Access Memory)

- Input Devices
- Output devices
- Communication interfaces
- Application-specific circuitry

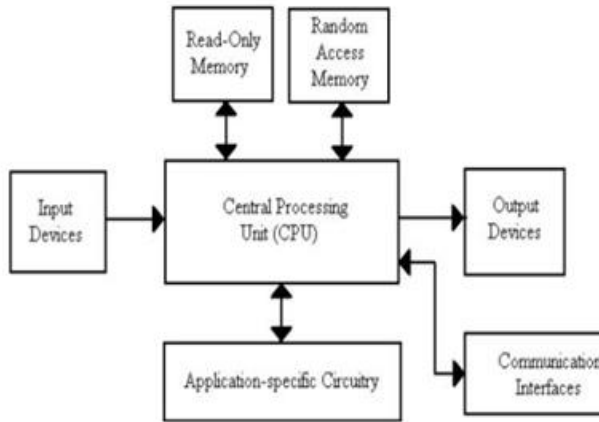

Fig: basic building blocks of Embedded System

Central Processing Unit (CPU):

The Central Processing Unit (processor, in short) can be any of the following: microcontroller, microprocessor or Digital Signal Processor (DSP). A micro-controller is a low-cost processor. Its main attraction is that on the chip itself, there will be many other components such as memory, serial communication interface, analog-to digital converter etc. So, for small applications, a micro-controller is the best choice as the number of external components required will be very less. On the other hand, microprocessors are more powerful, but you need to use many external components with them. DSP is used mainly for applications in which signal processing is involved such as audio and video processing.

Memory:

The memory is categorized as Random Access Memory (RAM) and Read Only Memory (ROM). The contents of the RAM will be erased if power is switched off to the chip, whereas ROM retains the contents even if the power is switched off. So, the firmware is stored in the ROM. When power is switched on, the processor reads the ROM; the program is executed.

Input devices:

Unlike the desktops, the input devices to an embedded system have very limited capability. There will be no keyboard or a mouse, and hence interacting with the embedded system is no easy task. Many embedded systems will have a small keypad-you press one key to give a specific command. A keypad may be used to input only the digits. Many embedded systems used in process control do not have any input device for user interaction; they take inputs from sensors or transducers and produce electrical signals that are in turn fed to other systems.

Output devices:

The output devices of the embedded systems also have very limited capability. Some embedded systems will have a few Light Emitting Diodes (LEDs) to indicate the health status of the system modules, or for visual indication of alarms. A small Liquid Crystal Display (LCD) may also be used to display some important parameters.

Communication interfaces:

The embedded systems may need to, interact with other embedded systems as they may have to transmit data to a desktop. To facilitate this, the embedded systems are provided with one or a few communication interfaces such as RS232, RS422, RS485, Universal Serial Bus (USB), and IEEE 1394, Ethernet etc.

Application-specific circuitry:

Sensors, transducers, special processing and control circuitry may be required for an embedded system, depending on its application. This circuitry interacts with the processor to carry out the necessary work. The entire hardware has to be given power supply either through the 230volts main supply or through a battery. The hardware has to design in such a way that the power consumption is minimized.

METHODOLOGY

Working

The proposed tracking system tracks sunlight more effectively by providing PV panel rotation along two different axis. The tracker is composed of four LDR sensors, two stepper motors and PIC microcontroller. A pair of sensors and one motor is used to tilt the tracker in sun's east-west direction and the other pair of sensors and the motor which is fixed at the bottom of the tracker is used to tilt the tracker in the sun's north-south direction. Two stepper motors are all in use in this system. Upper panel holder stepper motor tracks the sun linearly and base stepper motor tracks the parabolic displacement of the sun. These stepper motors and sensors are interfaced with a microcontroller. The microcontroller gives the command to the motors on the basis of sensors input. LDR sensors sense the light and send signal to microcontroller. Microcontroller does the comparison of signals received from LDR sensors and on the basis of stronger signal it is deciding rotation direction of stepper motors. Microcontroller is an intelligent device which functions on the basis of input that it receives from the sensor thus activating motor driver circuit. The controller activates driver circuits and moves stepper motors to new positions where light falling on sensor pairs is same. If difference arises, then the motor moves the panel until the light falling on the sensor is same. Algorithm takes data from the sensors. Analog signals from sensors are converted to digital signals using analog to digital converter (ADC). This ADC module has to be present in the microcontroller or has to be added externally. Digitized signals are forwarded to microcontroller. The step angle and movement direction of stepper motors is calculated once the digitized signal is received.

Block diagram

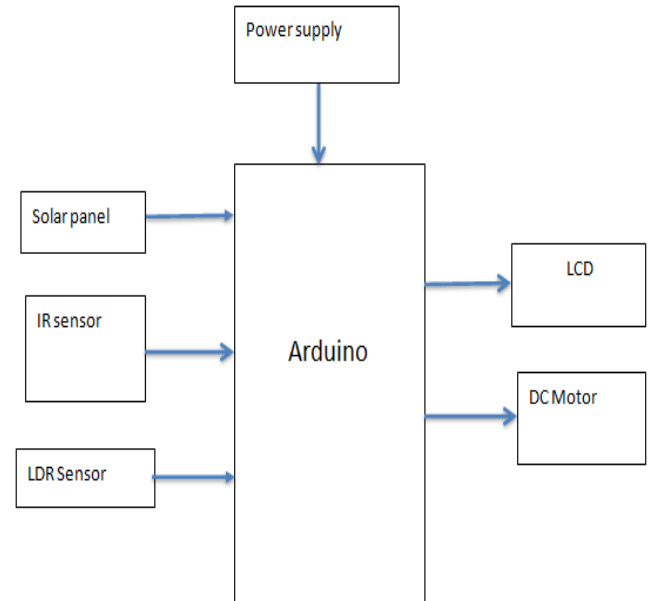

Advantages

algorithm it is known that, microcontroller drives stepper motors only if sensor light sensing is not equal to each other. Throughout this process the PV panel is adjusted in a position for optimum power that is normal to the sun. Voltage regulation is necessary in case of solar panels as it keeps varying. An algorithm can be used after the solar panel which regulates voltage coming from solar panel. Power generated from solar panel is used to energize Tracker circuitry. This makes the project economical and cost effective too. The PV panel is adjusted in a position for optimum power

Conclusion

Dual axis tracker perfectly aligns with the sun direction and tracks the sun movement in a more efficient way and has a tremendous performance improvement. The proposed system is cost effective also as a little modification in single axis tracker provided prominent power rise in the system

REFERENCES

1. Kais I. Abdul-lateef, A Low cost single-axis sun tracking system using PIC microcontroller, Diyala Journal of Engineering Sciences, Vol. 05, No. 01, pp.65-78, June 2012.
2. M. R. Patel, Wind and Solar Power Systems Design, Analysis and Operations, 2nd Edition, CRC Press Taylor & Francis Group Producing a PCB.n.d.,

- BocaRaton,2006.
3. ITACA, "The Sun As Source Of Energy, Part 1: Solar Astronomy. Online. Available at <http://www.itacanet.org/the-sun-as-a-source-of-energy/part-1-solar-astronomy/>
 4. Sedona Solar Technology,2017.Online.Availableat
 5. [:http://sedonasolartechnology.com/types-of-mounting-systems](http://sedonasolartechnology.com/types-of-mounting-systems)
 6. Solar Energy, "Apparent daily path of the sun across the sky from sunrise to sunset". <http://energyprofessionalsymposium.com/?p=10285>