



**ISSN: 2454-9940**



**INTERNATIONAL JOURNAL OF APPLIED  
SCIENCE ENGINEERING AND MANAGEMENT**

**E-Mail :**  
**editor.ijasem@gmail.com**  
**editor@ijasem.org**

**[www.ijasem.org](http://www.ijasem.org)**

## A Pick-n-Carry Mobile Crane Boom Stress Analysis

CH NAGAMANI<sup>1,2,3,4</sup>, Dr V VENUGOPAL<sup>1,2,3,4</sup>, K KRISHNAVENI<sup>1,2,3,4</sup>, RAHUL PATIL<sup>1,2,3,4</sup>

### ABSTRACT

Mobile crane telescopic booms that are light and sturdy are a rarity. Crane booms may be retracted and extended in a variety of ways. Although retraction of the crane's boom improves its performance, extending the boom reduces its operational capacity. Increasing the distance makes communication more difficult. The crane's lifting capacity decreases as it moves away from the load. It used to be that crane booms couldn't go to new heights, but that's no longer the case. When the crane's boom is fully extended and angled to the highest degree achievable This research relies on the utilisation of crane boom and component stress analysis. SAE J1078 [2] specifies that calculations must be done by hand. The crane boom may be more efficient if its weight and strength are maximised. The crane boom components are compared in this research.

*Keywords: Boom, Strength*

### Introduction

Because of their mobility, these cranes are widely utilised in the building industry It is possible for mobile cranes to lift and transport vast amounts of weight and mass. These cranes may also be moved on public highways, which is an added convenience. Booms are an essential component of mobile cranes. Facts are facts, and there's no arguing with them. Expandable booms that include at least two components Going backwards so you may rise even higher in the sky Crane lifts make use of portable components. The most typical causes of capacity problems are excessive strength or weight. After a while, things start to shift. The following are the most common causes of crane accidents: As a result, the structural integrity of mobile cranes is at risk. [2] They have a variety of downsides, including the fact that they are heavy-duty. for the consumer, lengthy booms that may be employed in a variety of situations are necessary booms that are too little or light have too much weight on them. The outermost rim of Boom's first portion It becomes more difficult to find a solution to the problem. With four pates in the boom, doing anything becomes more difficult. sections. The boom portions of cranes were made of wood in the past, but now they are made of metal. In

order for the meal to be complete, the most vital ingredient must be included in the next strongest and the largest. Extensions for the booster hose Theproduct's layout is a significant problem. strength and the capacity to alleviate fatigue symptoms The maximum load a mobile crane's boom can support. The collecting of data is required as a second phase.

### Objectives and Purpose

Manual calculation's main objective is to determine a value. evaluation of a person's talents Cranes with extendable extensions, such as this one, Analytical Reasoning"Training One of the key characteristics of a boom is its ability to provide a solution to the immediate problem. It's possible that the answer of an interaction equation will be less than or equal to one in certain cases. Taken into account are the many facets of this topic Torsional tension and bending are causing the panels to buckle and twist in both directions. Compressive stresses must be calculated [2]. That's what this investigation has discovered. Manual calculations are performed using SAE. The most extensively used standards in the business are AISC and J1078.

professor<sup>1,2,3,4</sup>, Assistant professor<sup>1,2,3,4</sup>,  
Department of Mechanical Engineering,  
Pallavi Engineering College,  
Kuntloor(V), Hayathnagar(M), Hyderabad, R.R.Dist.-501 505  
rahulpatiljkd@gmail.com.

## Methods and approaches

A boom is a must for any lifting operation to be effective. An very unusual occurrence. The crane's boom must be inspected for safety. Versatile in its use. In this article, an example is provided. The crane boom is subjected to a stress test. Breaking breaking a section into smaller sections. Jib is used for Hydra crane's 44-foot boom, which is 44 feet long. You might also look at the boom's lifting capacity, which is 12 tonnes.capacity. As part of the boom's design, the weights, etc. The object's dimensions and cross-sectional shape are shown in 3D computer graphicselements like hydraulic cylinders and boom sections TheMathematical calculations are required in order to carry out a boom-stress study. The following are examples of crane boom operating conditions: The boom has a 0° curve when completely extended. This is the point at which the boom reaches its maximum length a 55-degree incline is feasible. At a zero-degree angle, the boom has been fully retracted. The boom extends to a length of four feet when completely retracted. A 55 percent angle of view is achievable.

There are more than four possible scenarios in which forces and moments may be measured. This study examines some of the effects of stress. That concludes our look at the aforementioned four scenarios. The crane's retractable boom design The following images illustrate the user's current location and their stretched state. a minimum of two and a maximum of four distinct hypotheses There is minimal wind pressure on the head. Because of the side load, a lot of torque is generated on the head itself. The winch rope requires a 3 degree fleet angle.

## Negligible

The pressure of the wind is the same on each side. A reply is the focus of this section. Friction forces arise in axial strains in materials. Only a few reactivity points link the various components of the system. To other stressors and the weight it imposes. The axial loads are carried by the cylinders. How stress analysis calculations operate is explained here:

## Gather data as a starting point.

Included in this paper are details on boom height, operating distance, boom tilt, and rated load capacity. The first step is to figure out how the Boom is set up. b) The algorithm yields a shear diagram and a moment diagram. Secondly, the equations for the forces and moments have been deduced and

studied. Build a crane boom and identify its components.

## Analysis

The material's characteristics are well understood. Secondly, we have established the section's attributes. Consider the song's compressive and sectional characteristics in this period. Real and permissible quantities of stress may be calculated. Interaction equations and solutions. Stresses caused by compression. Web shear stress is determined in this step. In step 5, use tensile forces.

## Information Gathering

The Solidworks boom design is used to gather the data. Section characteristics and boom distances are inferred from the layout itself. each and every one of the characteristics necessary for based on current data, stress analysis calculations may be made. The boom's construction design.

W1 = Weight of Fly Jib = 80.198112kg = 196.7154 lb

W2 = Weight of 2<sup>nd</sup> Extension = 264.7109 kg = 583.7872 lb

W3 = Weight of 1<sup>st</sup> Extension = 401.292 kg = 884.9999 lb

W4 = Weight of Mother Boom = 711.29kg = 1568.662 lb

W5 = Weight of Extension Cylinder = 147 kg = 324.1903 lb

W6 = Weight of Lug 1 = 43 kg = 94.83118 lb

W7 = Weight of Lug 2 = 30.5 kg = 67.26398 lb

W8 = Weight of Lug 3 = 25.6 kg = 56.45763 lb

W9 = Weight of Hook Block = 149 kg = 328.6011 lb

Table 1: Boom distances

Boom Distances	Boom (Fully Extended) Boom length=13095mm	Boom (Fully Retracted) Boom length = 7801mm
<i>Fly Jib</i>		
Load pt. to 2nd ext. end pt. hor. (L1)	389.45mm(15.33268 in)	389.45 mm(15.33267in)
Load pt. to boom center line, ver. (L2)	103.35mm(4.068898 in)	103.35 mm(4.068897in)
Pulley center to 2nd ext. end pt., hor. (L3)	169.45mm(6.67126 in)	169.45 mm(6.671259 in)
Pulley outer to 2nd ext. end pt. ver. (L4)	185.65mm(7.309055 in)	185.65 mm(7.309055 in)
Pin point to flyjib head (L5)	191.38mm(7.534646 in)	191.38 mm(7.534645 in)
C.G. to flyjib center line, hor. (L6)	1.12mm(0.044094 in)	1.12 mm(0.044094in)
Pin point to flyjib center line, ver. (L7)	117.5mm(4.625984 in)	117.5 mm(4.625984 in)
<i>2nd Extension</i>		
Bottom pad to end pt. (L8)	2803.6mm(110.378 in)	111.88 mm(4.404724in)
Bottom pad to top pad, hor. (L9)	971.4mm(38.24409 in)	3663.12mm(144.2173in)
Bottom pad to C.G. (L10)	854.43mm(33.63898 in)	3719.22mm(146.4259in)
<i>1st Extension</i>		
Bottom pad on 2nd ext. to bottom pad on 1st ext.	2925mm(115.1575 in)	3719.22mm(146.4259in)
Bottom pad to top pad, hor. (L12)	1953.6mm(76.91339 in)	4392 mm(172.913386in)
Bottom pad to C.G. (L13)	520.73mm(20.50118 in)	3394.22mm(133.6307in)
Bottom pad on 2nd ext. to top pad on 1st ext. (L14)	1792mm(70.55118 in)	4717 mm(185.708661in)
Bottom pad to ext. cyl. Point on 1st extension (L15)	985.05mm(38.7815 in)	3585.05mm(141.1437in)

<i>Mother Boom</i>		
Top pad to lift cyl. (L16)	337mm(132.9528 in)	777 mm(30.5905512 in)
Bottom pad to lift cyl. (L17)	5169mm (203.5039 in)	5169 mm(203.50397 in)
Lift cyl. to boom pivot pt. (L18)	1806mm (71.10236 in)	1806.00mm(71.10236in)
Boom pivot pt. to C.G. (L19)	3167.72mm(124.713in)	3167.72mm(124.7133in)
Boom pivot pt. to boom center line (L20)	457.65mm(18.01772 in)	457.65mm(18.017716in)
Boom pivot pt. to extension cyl. pt. (L21)	389.9mm(15.35039in)	389.9 mm(15.350393in)
Boom pivot pt. to lift cyl. Pt. on chassis, hor. (L22)	3019.98mm (118.8969)	3019.98mm(118.8969in)
Boom pivot pt. to lift cyl. Pt. on boom, ver. (L23)	386.65mm(15.22244 in)	386.65mm(15.22244in)
Boom pivot pt. to lift cyl. Pt. on chassis, ver. (L24)	1572.5mm(61.90945in)	1572.5mm(61.90945in)
Boom pivot pt. to lug1, hor. (L25)	4505mm (177.3622 in)	4505 mm(177.3622in)
Boom pivot pt. to lug2, hor. (L26)	4805mm (189.1732 in)	4805.00mm(189.1733in)
Boom pivot pt. to lug3, hor. (L27)	5205mm(204.9213 in)	5205.00mm(204.9212in)
Boom pivot pt. to lug1, ver. (L28)	156.65mm(6.167323 in)	156.65 mm(6.167322in)
Boom pivot pt. to lug2, ver. (L29)	156.65mm(6.167323 in)	156.65 mm(6.16732in)
Boom pivot pt. to lug3, ver. (L30)	156.65mm(6.167323 in)	156.65mm(6.167322in)
Breadth of Mother Boom (L31)	325mm(12.79528)	325mm (12.79528in)

**Table 2: Cylinder data**

<i>Extension Cylinder Data</i>	<i>Lift Cylinder Data</i>
Bore = 100mm	Bore = 125mm
Stroke = 2100mm	Stroke = 1600mm
Closed Center Length = 2500mm	Closed Center Length = 1980mm
Width = 147 Kg	Number of Cylinders = 2

### 2.5.2 Material properties of crane boom

The material of boom of mobile crane is Mild steel having IS: 2062 grade having Ultimate tensile strength = 410Mpa, Yield strength = 250N/mm<sup>2</sup> = 36.2594344325 ksi, Poisson's ratio = 0.29, Mass density = 7.85kg/m<sup>2</sup>

**Table 3: Section Properties of 44' Crane Boom**

<i>Boom Sections</i>	<i>Mother Boom</i>	<i>1<sup>st</sup> Extension</i>	<i>2<sup>nd</sup> Extension</i>	<i>Fly Jib</i>
B(mm)	325	275	185	90
H(mm)	450	380	298	231
TTop(Tt)	8	8	8	4
TBottom(Tb)	10	8	8	4
TSide(Ts)	8	8	8	4
Length (Ls)	7100	5000	3900	4080
Ix(mm <sup>4</sup> )	39196.337	21655.059	9215.0811	1666.9225
Zx(mm <sup>3</sup> )	1742.06	1139.74	618.462	144.322
Iy(mm <sup>4</sup> )	22517.404	13155.701	4380.5343	378.69947
Zy(mm <sup>3</sup> )	1385.7	956.78	473.57	84.155
Area(mm <sup>2</sup> )	127.62	102.24	74.72	25.04
Volume(mm <sup>3</sup> )	90610.2	51120	29140.8	10216.32

In four circumstances, an external load is imposed. With rubber tyre mounted cranes, rated loads cannot exceed 85 percent of tipping load at the given radius. All external loads are taken into account. According to the load chart of a mobile crane (Figure 2).

**Table 4: Load lifted in four working conditions of crane boom**

<i>External load</i>	<i>Case-1 Boom</i>	<i>Case-2 Boom</i>	<i>Case-3 Boom</i>	<i>Case-4 Boom</i>
P (Kg)	3420	7623	2100	4230

### 2.5.4 Forces and moments in Boom sections [3]

#### a) Maximum load calculation

Where

$$P_z = P_1 \times SA$$

$$P_x = F_{ll} \times P_1$$

$$M_1 = (P_y \times Li_1) + (P_z \times Li_2) - P \times Li_4 + N$$

$$M_2 = P_x \times Li_1$$

$$T = P_x \times Li_2$$

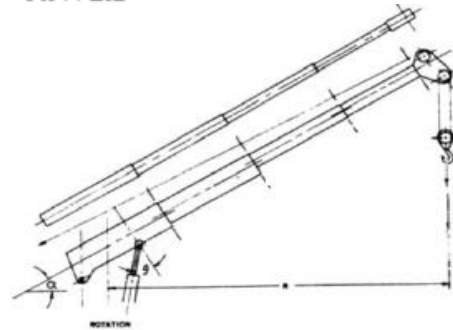

**Figure 1: Loading diagram – Boom Assembly [3]**

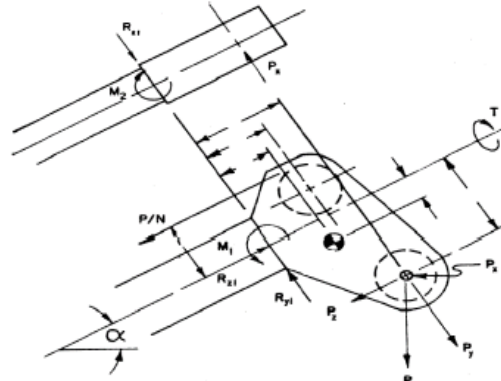

**Figure 2: Load moment diagram – Head section [3]**



**b) Forces and moment in flyjib [3]**

Moments

$$\begin{aligned} M_{x1} &= (P_y \times Li1) + (P_z \times Li2) - (P1 \div N) \\ &\quad \times Li4 + P_y \times Li5 + w1 \times CA \times Li6 \\ M_{y1} &= P_x \times Li1 + P_x \times Li5 + 0.5 \\ &\quad \times g_i \times d1 \times (Li5 \wedge 2) \end{aligned}$$

Axial Force

$$\begin{aligned} R_{z1} &= (P1 \div N) + P_z + (w1 \times SA) \\ Par1 &= (P1 \div N) + P_z + (w1 \times SA) \\ Pal1 &= w2 \times SA \end{aligned}$$

Vertical reactions

$$\begin{aligned} R_{y1} &= P_y + w1 \times CA \\ R_{x1} &= P_x + g_i \times d1 \times Li5 \\ V_{y1} &= P_y + w1 \times CA \\ V_{y1} &= R_y + w1 \times CA \\ V_{x1} &= P_x + g_i \times d1 \times Li5 \\ V_{x1} &= 0 \end{aligned}$$

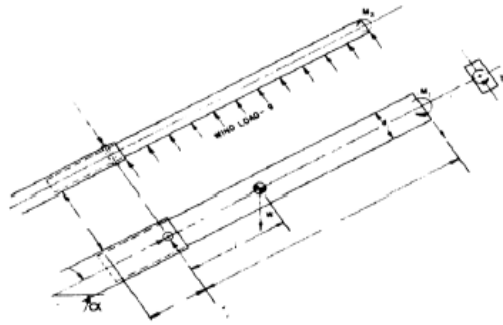

Figure 3: Load moment diagram – Flyjib [3]

**c) Forces and moments in 2<sup>nd</sup> Extension [3]**

Moments

$$\begin{aligned} M_{x2} &= M_{x1} + R_{y1} \times Li8 + \\ &\quad (0.5 \times w2 \times CA \times ((Li8 \wedge 2) \div (Li8 + Li9))) \\ M_{y2} &= M_{y1} + R_{x1} \times Li8 + \\ &\quad (0.5 \times g_i \times d2 \times (Li8 \wedge 2)) \end{aligned}$$

Axial Force

$$\begin{aligned} R_{z2} &= R_{z1} + w2 \times SA \\ Par2 &= R_{z1} + ((w2 \times SA \times Li8) \div (Li8 + Li9)) \end{aligned}$$

Vertical Reactions

$$\begin{aligned} R_{y3} &= (M_{x2} \div Li9) - ((0.5 \times w2 \times CA \times Li9) \\ &\quad \div (Li9 + Li8)) \\ R_{y2} &= R_{y1} + R_{y3} + w2 \times CA \\ R_{x3} &= M_{y2} \div Li9 \\ R_{x2} &= R_{x1} + R_{x3} + g_i \times d2 \times Li8 \end{aligned}$$

$$V_{y2} = R_{y1} + ((w2 \times CA \times Li8) \div (Li8 + Li9))$$

$$V_{y1} = R_{y3} + ((w2 \times CA \times Li9) \div (Li9 + Li8))$$

$$V_{x2} = R_{x1} + g_i \times d2 \times Li8$$

$$V_{x1} = R_{x3}$$

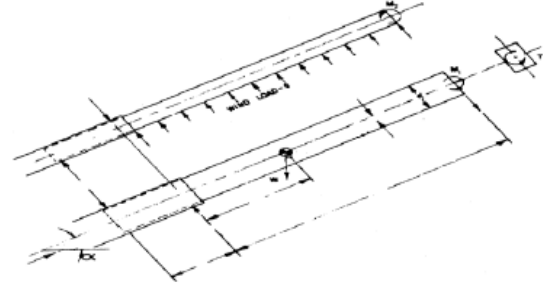

Figure 4: Load moment diagram 2<sup>nd</sup> Extension [3]

**d) Forces and moments in 1<sup>st</sup> Extension [3]**

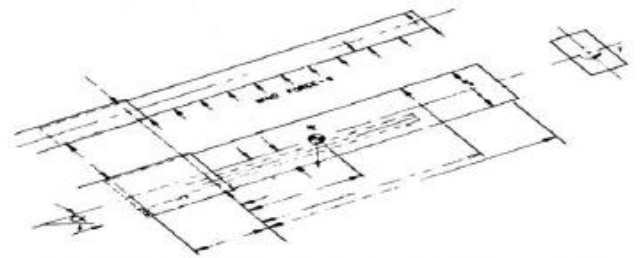

Figure 5: Load moment diagram 1<sup>st</sup> Extension [3]

Moments

$$\begin{aligned} M_{x3} &= R_{y2} \times Li11 - R_{y3} \times Li14 - w3 \times CA \times Li12 - w6 \times CA \times Li15 \\ M_{y3} &= R_{x2} \times Li11 - R_{x3} \times Li14 + (0.5 \times g_i \times d3 \times (Li11 \wedge 2)) \end{aligned}$$

$$R_{z3} = R_{z2} + w3 \times SA$$

$$Par3 = R_{z2} + ((w3 \times SA \times Li11) \div (Li11 + Li12))$$

$$Pal3 = ((w3 \times SA \times Li12) \div (Li11 + Li12))$$

Vertical reactions

$$R_{y5} = (M_{x3} \div Li12) - ((0.5 \times w3 \times CA \times Li12) \div (Li11 + Li12))$$

$$R_{y4} = R_{y2} - R_{y3} + R_{y5} + w3 \times CA + w6 \times CA$$

$$R_{x5} = (M_{y3} \div Li12)$$

$$R_{x4} = R_{x2} - R_{x3} + R_{x5} + g_i \times d3 \times Li11$$

$$V_{y3} = R_{y2} - R_{y3} + ((w3 \times CA \times Li11) \div (Li11 + Li12)) + w6 \times CA$$

$$V_{y1} = R_{y5} + ((w3 \times CA \times Li12) \div (Li11 + Li12))$$

$$V_{x3} = R_{x2} - R_{x3} + g_i \times d3 \times Li11$$

$$V_{x1} = R_{x5}$$

**e) Forces and moments in mother boom [3]**

Moments

$$\begin{aligned} M_{x4} &= (R_{y4} \times Li16) - (R_{y5} \times Li17) + ((0.5 \times w4 \times CA \times (Li16 \wedge 2)) \div (Li16 + \\ &\quad Li17)) + w7 \times Li25 + w8 \times Li26 + w9 \times Li27 + w5 \times Li27 + w5 \times Li21 \end{aligned}$$

$$M_{y4} = (R_{x4} \times Li16) - (R_{x5} \times Li17) + (0.5 \times g_i \times d4 \times (Li16 \wedge 2))$$

Axial load on cylinder

$$R_{z4} = R_{z3} + (w4 + w5 + w7 + w8 + w9) \times SA$$

Axial load on section

$$Par4 = (w4 \times Li16) \div (Li16 + Li18)$$

$$Pal4 = Par3$$

Derrick cylinder reaction

$$Rd = (Ry4 \times (Li16 + Li18) - Ry5 \times (Li17 + Li18) + w4 \times (Li19 \times CA - Li20 \times (w5 \times Li21 \times CA - Rz4 \times Li20) \div ((Li18 - ((Li20 - (d4 \div 2)) \div OT)) \times CT$$

Pivot Pin loading

$$Rx6 = Rx4 - Rx5 + gi \times d4 \times (Li16 + Li18)$$

$$Rzr6 = (Rd \times ST \div 2) + (Rx4 \times (Li16 + Li18) \div Li31) - (Rx5 \times (Li17 + Li18 Li31) - (Rz4 \div 2) + (w4 \times SA \div 2) + ((0.5 \times gi \times d4 \times ((Li16 + Li18) \wedge 2) \div li: ((w7 + w8 + w9) \times SA \div 2)$$

$$RZL6 = (Rd \times ST \div 2) - (Rx4 \times (Li16 + Li18) \div Li31) + (Rx5 \times (Li17 + Li18) \div Li31) - (Rz4 \div 2) + (w4 \times SA \div 2) - ((0.5 \times gi \times d4 \times ((Li16 + Li18) \wedge 2) \div Li31) + ((w7 + w8 + w9) \times SA \div 2)$$

$$Ryr6 = 0.5 \times (Rd \times CT + Ry5 - Ry4 - (w4 + w5 + w7 + w8 + w9) \times CA) - (Px \times (Li2 - Li20) \div Li31) + (gi \times d4 \times (Li16 + Li18) \times Li20 \div Li31)$$

$$Ryl6 = 0.5 \times (Rd \times CT + Ry5 - Ry4 - (w4 + w5 + w7 + w8 + w9) \times CA) + (Px \times (Li2 - Li20) \div Li31) - ((gi \times d4 \times (Li16 + Li18) \times Li20) \div Li31)$$

Vertical shear force

$$Vyr4 = Ry4 - Ry5 + ((w4 \times CA \times Li16) \div (Li16 + Li18))$$

$$Vyl4 = Ry4 - Ry5 + ((w4 \times CA \times Li16) \div (Li16 + Li18))$$

$$Vyl4 = Ryr6 + Ryl6 + ((w4 \times CA \times Li16) \div (Li16 + Li18)) + (w5 + w7 + w8 + w9) \times CA$$

Lateral shear force

$$Vxr4 = Rx4 - Rx5 + gi \times d4 \times Li16$$

$$Vxl4 = Rx4 - gi \times d4 \times Li18$$

Extension cylinder reaction

$$Recy = (w1 + w2 + w3 + w6 + P) \times SA$$

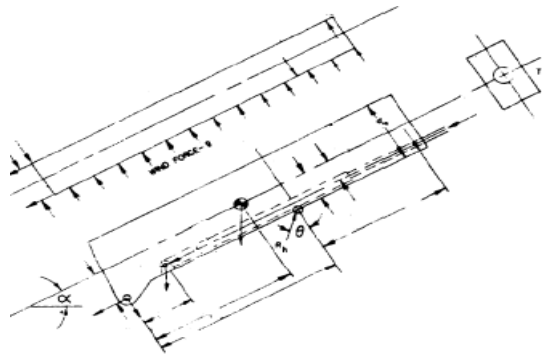

Figure 6: Mother Boom [3]

f) Calculations for forces and moments

Table 5: Maximum load calculation in four working conditions of boom

Max. load calculation	Case-1 Boom retracted at $\alpha=0$	Case-2 Boom retracted at $\alpha=55$	Case-3 Boom extended at $\alpha=0$	Case-4 Boom extended at $\alpha=55$
P1	7542.386912	16811.58346	4631.290209	9328.741707
Py	7542.386912	371.9858096	4631.290209	206.414794
Pz	0	-16807.46754	0	-9326.457782
Px	452.5432147	1008.695008	277.8774125	559.7245024
M1	107312.6607	-81256.63568	65893.73905	-45089.27836
M2	6938.699014	15465.99491	4260.604658	8582.075097
T	1841.352017	4104.276733	1130.654747	2277.461706

Table 6: Forces and Moments on Flyjib in four working conditions of boom

Forces & Moments in Fly Jib	Case-1 Boom retracted at $\alpha=0$	Case-2 Boom retracted at $\alpha=55$	Case-3 Boom extended at $\alpha=0$	Case-4 Boom extended at $\alpha=55$
Mx1	154106.0881	-100840.3028	94630.43061	-55956.17152
My1	10348.45181	23066.1544	6354.312523	12799.40092
Rz1	2514.128971	-11380.4301	1543.763403	-6393.700926
Par1	2514.128971	-11380.4301	1543.763403	-6393.700926
Pal1	0	-583.64426	0	-583.64426
Ry1	7719.253927	375.8993029	4828.00561	210.3282873
Rx1	452.5432206	1008.695013	277.8774184	559.7245083
Vyr1	7719.253927	375.8993029	4828.00561	210.3282873
Vyl1	7896.120941	379.8127962	5024.721012	214.2417806
Vxr1	452.5432206	1008.695013	277.8774184	559.7245083
Vxl1	0	0	0	0

Table 7: Forces and Moments on 2<sup>nd</sup> extension in four working conditions of boom

Forces & Moments in 2 <sup>nd</sup> Extension	Case-1 Boom retracted at $\alpha=0^\circ$	Case-2 Boom retracted at $\alpha=55^\circ$	Case-3 Boom extended at $\alpha=0^\circ$	Case-4 Boom extended at $\alpha=55^\circ$
Mx2	188145.379	-99183.72686	651463.7831	-46729.45479
My2	12341.77999	27509.17796	37025.85919	36960.10858
Rz2	2514.128971	-11964.07436	1543.763403	-6977.345186
Par2	2514.128971	-11397.72761	1543.763403	-6703.163914
Pal2	0	-566.3467448	0	-274.181272
Ry3	1021.353535	-694.0051988	16959.2515	-1224.907855
Ry2	9324.394649	-305.1885791	22371.04429	-1001.662251
Rx3	85.57765285	190.7480836	968.1457931	966.4265574
Rx2	538.1208778	1199.443101	1246.023322	1526.151109
Vyr2	7736.556678	376.2821345	5261.570045	217.1773762
Vyl2	1587.838971	-681.4707137	17109.47424	-1218.839627
Vxr2	452.543225	1008.695018	277.877529	559.7245515
Vxl2	85.57765285	190.7480836	968.1457931	966.4265574

Table 8: Forces and Moments on 1<sup>st</sup> extension in four working conditions of boom

Forces & Moments in 1 <sup>st</sup> Extension	Case-1 Boom retracted at $\alpha=0^\circ$	Case-2 Boom retracted at $\alpha=55^\circ$	Case-3 Boom extended at $\alpha=0^\circ$	Case-4 Boom extended at $\alpha=55^\circ$
Mx3	-236779.145	-17316.44824	1307951.838	28784.93906
My3	-9007.106321	152948.0703	75185.08548	86526.85779
Rz3	2514.128971	-12848.85755	1543.763403	-7862.128377
Par3	2514.128971	-12349.96065	1543.763403	-7841.970732
Pal2	0	-566.3467448	0	-274.181272
Ry5	-1781.362965	-105.6660519	16828.32043	8308.15707
Ry4	7501.509191	304.8310505	23219.94426	8553.083157
Rx5	-52.09027791	884.5357435	977.5292646	24974.79759
Rx4	-61.51303245	1044.541862	2235.05866	1166.037355
Vyr3	8458.84854	399.4554291	6037.232056	244.4799542
Vyl3	-957.3393497	-94.62437859	17182.71221	8308.603203
Vxr3	452.5432413	1008.695189	277.8776762	559.7247415
Vxl3	-52.09027791	884.5357435	977.5292646	24974.79759

Table 9: Forces and Moments on Mother boom in four positions of boom

Forces & Moments in Mother Boom	Case-1 Boom retracted at $\alpha=0^\circ$	Case-2 Boom retracted at $\alpha=55^\circ$	Case-3 Boom extended at $\alpha=0^\circ$	Case-4 Boom extended at $\alpha=5^\circ$
MX4	622711.8133	58484.59092	-201343.3013	-524573.7277
MY4	8718.859774	-148053.3942	98226.16802	-4927441.742
RZ4	2514.128971	-14864.93786	1543.763403	-10762.9921
PAR4	471.8739654	471.8739654	1022.066741	1598.691336
PAL4	2514.128971	-12349.96065	1543.763403	-7841.970732
Rd	-20926.87593	7006.081268	-4308.992559	-5657.970635
Rx6	-9.422600613	160.0062728	1257.529705	-23808.75992
Rz6	-628.0130257	-4095.315699	13892.86666	-489031.9266
Rz16	-1886.115945	17268.28419	-15436.63006	497218.1659
Ryr6	5041.759233	3054.470077	-1965.600278	-1335.467486
Ryl6	4055.075347	855.2041597	-2571.459408	-2498.579113
Vyr4	9754.746121	420.9381426	7413.690575	280.2999403
Vyl4	10016.62047	3930.026115	-2738.479954	-3788.761907
Vxr4	147.090947	-853.7935171	-1266.912751	-199.6107923
Vxl4	-61.51314008	1044.541755	2235.058553	1166.037247
Recy	0	-9361.192813	0	-5969.02351

## 2.6 Equations used for stress analysis:

### 2.6.1 Calculation of section properties based on compressive stresses

$$B_{tf} = B \div T_t$$

$$B_{tw} = H \div T_s$$

$$B_{ta} = 184 \div \text{Sqrt}(\text{Fost} \times F_{yi})$$

$$F_a = P_{ar} \div (A_s \times 1000)$$

$$F_{bx} = M_x \div (Z_x \times 1000)$$

$$F_{by} = M_y \div (Z_y \times 1000)$$

$$F_f = F_a + F_{bx}$$

$$F_w = F_a + F_{by}$$

If  $(B_{tf} \leq B_{ta})$  and  $(B_{tw} \leq B_{ta})$  Then the plates in compression are fully effective at yield [10].

$$B_{txr} = 184 \div \text{Sqrt}(\text{Abs}(F_f))$$

$$B_{tyr} = 184 \div \text{Sqrt}(\text{Abs}(F_w))$$

If  $(B_{TF} \leq B_{TXR})$  and  $(B_{TW} \leq B_{TYR})$  Then the plates in compression are fully effective at actual stress [10].

$$B_{tq} = T_s \div T_b$$

If  $B_{tq} \leq 95 \div \text{Sqr}(F_{Yi})$  Then  $Q_s = 1$

$$S_{igr} = 0.5 \times F_{yi}$$

$$R_x = \text{Sqrt}(I_x \div A_s)$$

$$R_y = \text{Sqrt}(I_y \div A_s)$$

$$C_c = \text{Sqrt}((\pi)^2 \times E \div (Q_s \times Q_a \times (F_{yi} - S_{igr})))$$

$$K_{lx} = k \times L_s \div R_x$$

$$K_{ly} = k \times L_s \div R_y$$

If  $K_{lx} < K_{ly}$  then  $K_l = K_{ly}$

If  $K_l > C_c$  then, Elastic range

$$F_{aa} = 12 \times (\pi)^2 \times E \div (23 \times (K_l)^2)$$

If  $K_l < C_c$

$$F_{aa} = Q_s \times Q_a \times \left(1 - S_{igr} \times ((K_l)^2) \div (F_{yi} \times (C_c)^2)\right) \times F_{yi} \div (5 \div 3) + (3 \div 8) \times (K_l \div C_c) - (1 \div 8) \times ((K_l \div C_c)^3)$$

### 2.6.2 Inelastic lateral Buckling

If  $M_1 > M_2$  then  $M_{x\min} = M_1$

And  $M_{x\max} = M_x$

$$B_m = B - T_s$$

$$H_m = H - ((T_t + T_b) \div 2)$$

$$J = 4 \times (B_m \wedge 2) \times (H_m \wedge 2) \div ((2 \times H_m \div T_s) + (B \div T_b) + (B \div T_t))$$

### 2.6.3 Inelastic Lateral buckling check

$$C_b = 1.75 + 1.05 \times (M_{x\min} \div M_{x\max}) + 0.3 \times ((M_{x\min} \div M_{x\max}) \wedge 2)$$

Where  $1 \leq C_b \leq 1.3$

$$K_{le} = \text{Sqrt}(5.1 \times K_t \times L_s \times Z_x \div \text{Sqrt}(J \times I_y))$$

If  $K_{le} < (102000 \div F_{Yi})$  than

$$F_{bxa} = \text{Fost} \times F_{yi}$$

$$F_{bya} = \text{Fost} \times F_{yi}$$

### 2.6.4 Solution to interaction equations for compressive stresses

$$X_a = \text{Abs}(F_a \div F_{aa}), X_b = \text{Abs}(F_{bx} \div F_{bxa}),$$

$$X_c = \text{Abs}(F_{by} \div F_{bya})$$

$$F_{ex} = 12 \times (\pi)^2 \times E \div (23 \times (K_{lx})^2)$$

$$F_{ey} = 12 \times (\pi)^2 \times E \div (23 \times (K_{ly})^2)$$

If  $X_a \leq 0.15$  than  $X_d = X_a + X_b + X_c$

If  $X_d \leq 1$  than the design will be safe against buckling

And if  $X_d > 1$ , Than  $X_d = (F_a \div (\text{Fost} \times F_{yi})) + X_b + X_c$  And

$$X_{d1} = X_a + C_{mx} \times F_{bx} \div ((1 - (F_a \div F_{ex})) \times (F_{bxa}) + C_{my} \times F_{by} \div ((1 - (F_a \div F_{ey})) \times F_{bya}))$$

If  $X_d$  and  $X_{d1}$  equal to or less than one than the design will be safe

### 2.6.5 Actual and allowable shear stresses in webs

$$F_s = (V_{yr} \div (2 \times B \times T_s) + T \div (2 \times A_s \times T_s)) \div 1000$$

If  $H \div T \leq 380 \div \text{Sqrt}(F_{Yi})$  than  $F_{sa} = 0.4 \times F_{Yi}$

And if  $F_{sa} = 0.4 \leq F_{Yi}$  than stiffeners are not required

If  $\text{Abs}(F_s) \leq \text{Abs}(F_{sa})$  than the design will be safe against shear

### 2.6.6 Tensile stresses

$$F_t = (-F_a + F_{bx} + F_{by})$$

$$F_{ta} = (\text{Fost} \times F_{Yi})$$

If  $F_t \leq F_{ta}$ , than the design will be safe against tensile failure

## 2.7 Calculations for stress analysis

### 2.7.1 Case – 1 When the boom is fully retracted and at an angle = $0^\circ$



**Table 10: Calculation of section properties based on Compressive stresses**

Parameters	Flyjib	2 <sup>nd</sup> extension	1 <sup>st</sup> extension	Mother boom
Btf	22.5	23.125	34.375	40.625
Btw	57.75	37.25	47.5	56.25
Bta	37.52760125	37.52760125	37.52760125	37.52760125
Fa	0.647769747	0.217079155	0.158647833	0.023854741
Fbx	17.49799981	4.985189659	-3.404386091	5.857673294
Fby	2.015089483	0.427064602	-0.154267742	0.261896522
Ff	18.14576956	5.202268814	-3.245738257	5.881528035
Fw	2.662859231	0.644143757	0.004380091	0.285751263
Btxr	43.19466672	80.67174073	102.1318211	75.87046351
Btyr	112.7570535	229.259015	278.201253	344.2102065

**Table 11: Calculation for determination of allowable stresses**

Parameters	Flyjib	2 <sup>nd</sup> extension	1 <sup>st</sup> extension	Mother boom
Btq	1	1	1	0.8
Qs	1	1	1	1
Qa	1	1	1	1
Sigr	18.21210326	18.21210326	18.21210326	18.21210326
Rx	3.212231386	4.372173945	5.729818869	6.899691211
Ry	1.531074066	3.014471493	4.465939585	5.22957065
Cc	126.4389349	126.4389349	126.4389349	126.4389349
Klx	100.0114263	81.27634792	68.71086092	81.02610697
Kly	209.8264543	117.8827969	88.15631737	106.9026801
KI	209.8264543	117.8827969	88.15631737	106.9026801
Faa	3.450282756	10.75387107	14.62058838	12.26578541

**Table 12: Inelastic lateral buckling check**

Parameters	Flyjib	2 <sup>nd</sup> extension	1 <sup>st</sup> extension	Mother boom
Mxmax	107312.6607	107312.6607	-236779.145	622711.8133
Mxmin	154106.0881	188145.379	107312.6607	107312.6607
Bm	3.385826772	6.968503937	10.51181102	12.48031496
Hm	8.937007874	11.41732283	14.64566929	17.36220472
J	23.10704846	213.2229929	586.1236399	14.4505726
Cb	1.3	1.3	1.3	1.939857148
Kle	22.59101563	15.3019954	12.89915202	1024.190401
Fbxa	24.0399763	24.0399763	24.0399763	24.0399763
Fbya	24.0399763	24.0399763	24.0399763	24.0399763

**Table 13: Solution to interaction equations for the**

Parameters	Flyjib	2 <sup>nd</sup> extension	1 <sup>st</sup> exte
Xa	0.18774396	0.020186141	0.0108
Xb	0.727870926	0.207370823	0.1416
Xc	0.08382244	0.017764768	0.0064
Fex	15.18713766	22.9957093	32.175
Fey	3.450282756	10.93136281	19.546
Xd	0.999437326	0.245321731	0.1588

**Table 14: Calculation of Actual and Allowable shear stress in the webs**

Parameters	Flyjib	2 <sup>nd</sup> extension	1 <sup>st</sup> extension	Mother boom
Fs	8.423187941	1.938650714	1.424902372	13.29223421
H/Ts	57.75	37.25	47.5	56.25
Fsa	14.56968261	14.56968261	14.56968261	14.56968261

**Table 15: Calculation of tensile stresses**

Parameters	Flyjib	2 <sup>nd</sup> extension	1 <sup>st</sup> extension	Mother boom
Ft	18.86531955	5.195175106	-3.717301666	6.095715074
Fta	24.0399763	24.0399763	24.0399763	24.0399763

**2.7.2 Case – 2 When the boom is fully retracted and at an angle = 55°**

**Table 16: Calculation of section properties based on Compressive stresses**

Parameters	Flyjib	2 <sup>nd</sup> extension	1 <sup>st</sup> extension	Mother boom
Btf	22.5	23.125	34.375	40.625
Btw	57.75	37.25	47.5	56.25
Bta	37.52760125	37.52760125	37.52760125	37.52760125
Fa	-2.93218781	-0.984121781	-0.77931344	0.023854741
Fbx	-11.4499279	-2.628019312	-0.248974104	0.550147948
Fby	4.491528395	0.951904517	2.619593083	-4.447217864
Ff	-14.3821157	-3.612141093	-1.028287544	0.574002689
Fw	1.559340583	-0.032217263	1.840279643	-4.423363123
Btxr	48.51839586	96.81339948	181.4514886	242.8627227
Btyr	147.3490473	1025.117154	135.6362931	87.48659752

**Table 17: Calculation for determination of allowable stresses**

Parameters	Flyjib	2 <sup>nd</sup> extension	1 <sup>st</sup> extension	Mother boom
Btq	1	1	1	0.8
Qs	1	1	1	1
Qa	1	1	1	1
Sigr	18.21210326	18.21210326	18.21210326	18.21210326
Rx	3.212231386	4.372173945	5.729818869	6.899691211
Ry	1.531074066	3.014471493	4.465939585	5.22957065
Cc	126.4389349	126.4389349	126.4389349	126.4389349
Klx	100.0114263	81.27634792	68.71086092	81.02610697
Kly	209.8264543	117.8827969	88.15631737	106.9026801
KI	209.8264543	117.8827969	88.15631737	106.9026801
Faa	3.450282756	10.75387107	14.62058838	12.26578541

**Table 18: Inelastic lateral buckling check**

Parameters	Flyjib	2 <sup>nd</sup> extension	1 <sup>st</sup> extension	Mother boom
Mxmax	-100840.303	-99183.72686	-17316.44824	58484.59092
Mxmin	-81256.6357	-81256.63568	-81256.63568	-81256.63568
Bm	3.385826772	6.968503937	10.51181102	12.48031496
Hm	8.937007874	11.41732283	14.64566929	17.36220472
J	23.10704846	213.2229929	586.1236399	1024.190401
Cb	1.3	1.3	1.3	1
Kle	22.59101563	15.3019954	12.89915202	16.47618776
Fbxa	24.0399763	24.0399763	24.0399763	24.0399763
Fbya	24.0399763	24.0399763	24.0399763	24.0399763



**Table 19: Solution to interaction equations for the Compressive Stresse**

Parameters	Flyjib	2 <sup>nd</sup> extension	1 <sup>st</sup> extension	Mother boom
Xa	0.84983986	0.091513258	0.039869783	0.00194482
Xb	0.476286988	0.109318715	0.01035667	0.022884713
Xc	0.186835808	0.039596733	0.108968206	0.184992606
Fex	15.18713766	22.9957093	32.17543233	23.13796849
Fey	3.450282756	10.93136281	19.54646796	13.29223421
Xd	Xd = 0.663123 Xd1 = 0.669321	0.240428706	0.159194659	0.209822138

**Table 20: Calculation of Actual and Allowable shear stress in the webs**

Parameters	Flyjib	2 <sup>nd</sup> extension	1 <sup>st</sup> extension	Mother boom
Fs	3.694306965	0.644589912	0.469717905	0.381606865
H/Ts	57.75	37.25	47.5	56.25
Fsa	14.56968261	14.56968261	14.56968261	14.56968261

**Table 21: Calculation of tensile stresses**

Parameters	Flyjib	2 <sup>nd</sup> extension	1 <sup>st</sup> extension	Mother boom
Ft	-4.0262117	-0.691993014	3.149932419	-3.920924657
Fta	24.0399763	24.0399763	24.0399763	24.0399763

**2.7.3 Case – 3 When the boom is fully extended and at an angle = 0°**

**Table 22: Calculation of section properties based on Compressive stresses**

Parameters	Flyjib	2 <sup>nd</sup> extension	1 <sup>st</sup> extension	Mother boom
Btf	22.5	23.125	34.375	40.625
Btw	57.75	37.25	47.5	56.25
Bta	37.52760125	37.52760125	37.52760125	37.61277208
Fa	0.397753353	0.133294218	0.097415336	0.051668749
Fbx	10.744827	17.26149498	18.80559643	-1.86861933
Fby	1.237335649	1.281211771	1.287720267	2.950511007
Ff	11.14258036	17.3947892	18.90301177	-1.816950581
Fw	1.635089003	1.41450599	1.385135603	3.002179756
Btxr	55.12199605	44.11723016	42.32064915	136.504279
Btyr	143.8954707	154.7089461	156.3405649	106.1938771

**Table 23: Calculation for determination of allowable stresses**

Parameters	Flyjib	2 <sup>nd</sup> extension	1 <sup>st</sup> extension	Mother boom
Btq	1	1	1	0.8
Qs	1	1	1	1
Qa	1	1	1	1
Sigr	18.21210326	18.21210326	18.21210326	18.12971722
Rx	3.212231386	4.372173945	5.729818869	6.899691211
Ry	1.531074066	3.014471493	4.465939585	5.22957065
Cc	126.4389349	126.4389349	126.4389349	126.4389349
Klx	100.0114263	81.27634792	68.71086092	81.02610697
Kly	209.8264543	117.8827969	88.15631737	106.9026801
Kl	209.8264543	117.8827969	88.15631737	106.9026801
Faa	3.450282756	12.92512958	14.62058838	12.2423439

**Table 24: Inelastic lateral buckling check**

Parameters	Flyjib	2 <sup>nd</sup> extension	1 <sup>st</sup> extension	Mother boom
Mxmax	94630.43061	651463.7831	1307951.838	-198647.3593
Mxmin	65893.73905	65893.73905	65893.73905	65893.73905
Bm	3.385826772	6.968503937	10.51181102	12.48031496
Hm	8.937007874	11.41732283	14.64566929	17.36220472
J	23.10704846	213.2229929	586.1236399	1024.190401
Cb	1.3	1.3	1.3	1.3
Kle	22.59101563	15.3019954	12.89915202	14.4505726
Fbxa	24.0399763	24.0399763	24.0399763	24.0399763
Fbya	24.0399763	24.0399763	24.0399763	24.0399763

**Table 25: Solution to interaction equations for the Compressive Stresses**

Parameters	Flyjib	2 <sup>nd</sup> extension	3 <sup>rd</sup> extension	Mother boom
Xa	0.049756429	0.010312795	0.006662888	0.004220495
Xb	0.446956639	0.718032945	0.782263518	0.073594439
Xc	0.05146992	0.053295051	0.053565788	0.123291256
Fex	15.18713766	30.79273489	32.17543233	23.13796849
Fey	3.450282756	14.63779841	19.54646796	13.29223421
Xd	0.548182987	0.781640792	0.842492193	0.20110619

**Table 26: Calculation of Actual and Allowable shear stress in the webs**

Parameters	Flyjib	2 <sup>nd</sup> extension	1 <sup>st</sup> extension	Mother boom
Fs	5.251086953	1.301788484	0.998486465	0.998248754
H/Ts	57.75	37.25	47.5	56.25
Fsa	14.56968261	14.56968261	14.56968261	14.56968261

**Table 27: Calculation of tensile stresses**

Parameters	Flyjib	2 <sup>nd</sup> extension	1 <sup>st</sup> extension	Mother boom
Ft	11.5844093	18.40941253	19.99590136	1.030222927
Fta	24.0399763	24.0399763	24.0399763	24.0399763

**2.7.4 Case – 4 When the boom is fully extended and at an angle = 55°**

In this case the side thickness is taken as 16mm and total breadth of mother boom is taken 341mm. Because the strength required for mother boom is high when the boom has to work at 55 degree angle and boom is in extended position.

**Table 28: Calculation of section properties based on Compressive stresses**

Parameters	Flyjib	2 <sup>nd</sup> extension	1 <sup>st</sup> extension	Mother boom
Btf	22.5	23.125	34.375	42.625
Btw	57.75	37.25	47.5	28.125
Bta	37.52760125	37.52760125	37.52760125	37.52760125
Fa	-1.64734828	-	-	0.051668756
Fbx	-6.35355222	-	0.410112361	-3.76680393
Fby	2.492347518	1.278936593	1.481974619	-
Ff	-8.0009005	-	-	-
Fw	0.84499924	0.703790157	0.992129202	-
Btxr	65.05016286	136.6211111	651.6263213	95.4619965
Btyr	200.1657019	219.329086	184.7284162	32.34760603

**Table 29: Calculation for determination of allowable stresses**

Parameters	Flyjib	2 <sup>nd</sup> extension	1 <sup>st</sup> extension	Mother boom
Btq	1	1	1	1.6
Qs	1	1	1	1
Qa	1	1	1	1
Sigr	18.21210326	18.21210326	18.21210326	18.21210326
Rx	3.212231386	4.372173945	5.729818869	6.314209581
Ry	1.531074066	3.014471493	4.465939585	5.743301605
Cc	126.4389349	126.4389349	126.4389349	126.4389349
Klx	100.0114263	70.23659581	68.71086092	88.53920842
Kly	209.8264543	101.8707972	88.15631737	97.34037259
Kl	209.8264543	101.8707972	88.15631737	97.34037259
Faa	3.450282756	12.92512958	14.62058838	13.50143141

**Table 30: Inelastic lateral buckling check**

Parameter	Flyjib	2 <sup>nd</sup> extension	1 <sup>st</sup> extension	Mother boom
Mxmax	-55956.1715	-46749.53354	28523.80769	-524573.7277
Mxmin	-45089.2784	-45089.27836	-45089.27836	-45089.27836
Bm	-55956.1715	6.968503937	10.51181102	12.79527559
Hm	3.385826772	11.41732283	14.64566929	17.36220472
J	23.10704846	213.2229929	586.1236399	1497.231279
Cb	1.3	1.3	1	1.3
Kle	22.59101563	14.22485027	14.70729614	12.83437332
Fbxa	24.0399763	24.0399763	24.0399763	24.0399763
Fbya	24.0399763	24.0399763	24.0399763	24.0399763

**Table 31: Solution to interaction equations for the Compressive Stresses**

Parameters	Flyjib	2 <sup>nd</sup> extension	1 <sup>st</sup> extension	Mother boom
Xa	0.477453123	0.044498311	0.03350381	0.003826909
Xb	0.236758298	0.051526587	0.017059599	-0.15668917
Xc	0.103675124	0.05320041	0.06164626	-1.348063316
Fex	15.18713766	30.79273489	32.17543233	19.37777468
Fey	3.450282756	14.63779841	19.54646796	16.03205385
Xd	0.817886545	0.149225308	0.112209669	-1.500925576

**Table 32: Calculation of Actual and Allowable shear stress in the webs**

Parameters	Flyjib	2 <sup>nd</sup> extension	1 <sup>st</sup> extension	Mother boom
Fs	2.051452949	0.359306127	0.2637354	0.074997356
H/Ts	57.75	37.25	47.5	28.125
Fsa	14.56968261	14.56968261	14.56968261	14.56968261

**Table 33: Calculation of tensile stresses**

Parameters	Flyjib	2 <sup>nd</sup> extension	1 <sup>st</sup> extension	Mother boom
Ft	-2.21385643	0.6153851	2.381932396	-36.22588286
Fta	24.0399763	24.0399763	24.0399763	24.0399763

## CONCLUSION

Four separate human calculations are carried out in order to assure the safety of the boom design under high loading conditions. Workplace conditions The boom sinks to its lowest position as it retracts. The strain on the system is reduced when the boom angle is zero degrees. At a 55-degree angle, the horn was sounded for maximum impact. The boom, on the other hand, is sometimes widened and put to use. The automated technique reveals more information than the human method does. The boom, according to the calculations, will not break under any kind of strain. If the boom angle exceeds 30 degrees, zero-degree boom operation is not safe. 55°. Compression is where you'll find plates that are either under or overstressed. Reactive, yet unable to provide outcomes in the actual world. The stiffeners engage when the boom is angled at a 55-degree angle. The mother's nurturing of a child's stamina is essential. The boom may be set to a 55-degree angle using the manual control. Stiffeners in the computations improve the accuracy of the results.

## References

- [1] Lawrence K. Shapiro and Jay P. Shapiro, "Cranes and Derricks" Fourth edition McGraw Hill.1980
- [2] SAE J1078 Reaffirmed APR94, "A Recommended method of analytically determining the competence of hydraulic telescopic cantilevered crane booms."
- [3] Navneet Kumar and Mohd. Parvez, "Force distribution on telescopic boom of crane." Int. J. Mech. Eng. & Rob. Res.2012 Vol.1, No.2, ISSN 2278-0149
- [4] Marquez, P. Venturino and J. L. Otegui, "Common root causes in recent failures of cranes." Engineering Failure Analysis 2014; 39: 55-64
- [5] Guangfu Sun and MichealKleeberger, "Complete dynamic calculation of lattice mobile crane during hoisting motion." Mechanism and Machine theory 2005;40: 447-466
- [6] IS: 4573 1982, Edition 2.1 (1989-09) Specification for Power Driven Mobile Cranes
- [7] IS:2062(2011) Hot rolled medium and high tensile structural steel.
- [8] ISO 4309 Cranes – Wire ropes Code of practice for examination and discard
- [9] ISO 4310 Cranes- Test code and procedures
- [10] AISC "Specification for structural steel buildings – Allowable stress design and Plastic design." June1, 1989 with commentary
- [11] Richard L. Neitzel, Noah S. Seixas and Kyle K. Ren, "A review of crane safety in the construction industry"2001;16(12):1106-1117