



**ISSN: 2454-9940**



**INTERNATIONAL JOURNAL OF APPLIED  
SCIENCE ENGINEERING AND MANAGEMENT**

**E-Mail :**  
**editor.ijasem@gmail.com**  
**editor@ijasem.org**

**[www.ijasem.org](http://www.ijasem.org)**

# Recent Mimo Wireless System In antenna design schemes

Dr.Tejawath Ramakrishna<sup>1</sup>,T.Sravanth<sup>2</sup>,K.Ram Mohan Rao<sup>3</sup>

---

## Abstract:

*Multi-input Multi-output (MIMO) and diversity technology have recently attracted considerable attention in both industry and academia due to high data rates and high spectrum efficiency. The multiple/MIMO techniques can increase the number of antennas on the transmitter and/or receptor side of the wireless link without needing additional power or spectrum in a rich scattering environment. However, the correlation coefficients between MIMO antenna elements are usually very high, due to the small space of mobile devices and the overall efficiency of MIMO elements would be severely degraded by the interconnected connections. Furthermore, the human body causes high electromagnetic waves losses. The presence of users in actual applications could significantly reduce the total efficiency of the antenna, and the correlations of MIMO antenna systems are also greatly affected. This chapter examines the performance of some basic MIMO antennas as well as the recent technologies to improve the performance of MIMO antennas on mobile devices and terminals. In mobile terminal applications, the interactions between MIMO antennas and human body are also targeted.*

---

**Keywords:** Multiplexing Antenna array Mobile handset antenna Long Term Evolution (LTE) WiFi Over-The-Air (OTA) performance Human body effect Specific Absorption Rate (SAR)

---

## 1. Introduction

For many years since 1960, antenna diversity techniques have been introduced into communication systems (Pierce and Stein 1960; Schwartz et al. 1965; Jakes 1974). In the late 1970s, the diversity technique was used with multi-antenna systems to overcome degradation by decaying environments (Taga 1990; Pedersen and Andersen 1999; Ogawa et al. 2001). In order to achieve good performance of diversity, multi-antenna systems typically require low reciprocal loss and a low pattern correlation between radiating elements. Independent fading signals (branches of diversity) are achieved not only via spaced antennas, spatial diversity and other techniques such as frequency diversity, angle of arrival diversity, polarization diversity, time diversity and multipath diversity. A system's overall diversity performance usually results from different diversity mechanisms. Since 1985, mobile communications systems have evolved quickly from analogue system

(1G) to digital (2G: second-generation system) and later to third-generation (3G), supporting multimedia transmission. MIMO technology has become an important feature in the LTE wireless communication systems in order to increase data transmission further (4G: fourth generation system). In the last decade, MIMO has been a great success in Wireless communication and can linearly increase the channel capacity by increasing the number of antennas without the need for additional frequency spectrum or power. In addition, the most popular wireless communication systems typically operate in a wide range of dispersion environments, including LTE cell phones of 4th generation and WiFi IEEE 802.11n, where MIMO uses the above-mentioned high-performance gains. A multi-antenna system can operate in the latest modern Smartphone under a rich dispersion schema, depending on the signal-to-noise (SNR) level.

---

*Professor<sup>1</sup>, Assistant Professor<sup>2,3</sup>  
Department of ECE Engineering,  
Pallavi Engineering College,  
Mail ID:pectejawath@gmail.com, Mail.id: ec\_sravanthi@pallaviengineeringcollege.ac.in, Mail ID:rammohan9@gmail.com,  
Kuntloor(V),Hayathnagar(M),Hyderabad,R.R.Dist.-501505.*

---

The phone supports multi-band and multimode operations as well. Due to a limited space of the mobile terminal, the coefficient of correlation between multiple antenna elements could be very high, thereby seriously degrading the corresponding bandwidth and overall efficiency. In addition, the human body causes high electromagnetic energy losses. In practical applications, the presence of users generally reduces total antenna efficiency significantly and changes the correlation within a MIMO antenna system. Different standards and requirements must be met by mobile terminals. For example, many telecommunications operators required the RF OTA performance of mobile telephones with impact. Furthermore, SAR of a mobile terminal shows how much RF radiation a human body can emit via radio. Mobile terminals' SAR values are strictly restricted by government regulations. It is true that MIMO technology can increase the system's channel capacity, but the complexity of the SAR issue is thus increased.

## 1. Performance Characterization of Diversity and MIMO Antennas

### Diversity Technology in Mobile Communications

#### 1.2 Temporary diversity

Space or spatial diversity is the most common and perhaps the simplest mechanism to achieve diversity. With two separate antennas at a distance, the phase delay makes it possible to differentiate between the signals reaching the antenna elements. The minimum distance between the antenna elements at a mobile terminal is usually 0.5 wavelengths, which are calculated by the zero-order Bessel function, to obtain a low enough correlation between fading signals. This does not include the effects of mutual connections that could be relevant for the system. Other diversity mechanisms should be incorporated in antenna spacing less than 0.5 wavelengths. Recently, as the operating frequency of mobile systems is increasing, space diversity has again drawn the attention of researchers.

#### 1.3 Diversity of frequency

Frequency diversity is described as the transmission of a signal on two or more different frequency transmissions so that different versions of signals can be achieved with different independent fadings. It is a costly mechanism due to the complexity of generating several transmitted signals and of combining signals at different frequencies on the receiver.

#### 1.4 Diversity of Angles

Signals coming from different angles or directions on antennas. These signals, regardless of their fading variations, can be used for angle or angular diversity. At a mobile terminal, the variety of angles can be achieved by using two omnidirectional antennas [1482]. Z. Ying et al. that act as parasites. The radiation patterns can be switched to manage signal reception at different angles.

#### 1.5 Diversities in time and time

Time and diversity are associated mechanisms that are most likely used for digital transmission. Time diversity is achieved through the repetitive transmission of a single bit of information at different times. Fading variations will become independent for these various signal repetitions. Multipath diversity in multipath environments uses time diversity. Repetitive signals will be transmitted to the recipient on various routes.

#### 1.6 Diversity of polarization

The transmission of one (depolarized by the propagating medium) polarization gives uncorrelated possibility of two orthogonal polarizations with fading variations. This diversity mechanism is relatively practical because antennas can be used in much smaller sizes. It is also the most commonly combined mechanism with spaced diversity.

## 2. Wireless Communications

### MIMO

There is one transmitter and one recipient in a conventional wireless system called a single-input single-output system (SISO). In a narrow band condition and the static environment (invariant frequency and time), the scalar signal mode can be indicated.

$$y = hx + n, \quad (1)$$

Where  $y$  is received signal,  $x$  is the transmitted signal, and  $n$  is marked by the Gaussian additive noise (AWGN) of nil mean and variance. The channel capacity of SISO is limited by Shannon for a bandwidth of 1 Hz.

$$C = \log_2 \left( 1 + \frac{E_s}{N_0} |h|^2 \right) \quad (2)$$

Where  $E_s$  and  $|h|^2$  are the scalar channel's total transmitting power and gain. The channel capacity of a SISO system is noted logarithmically increased with an increase in transmission power. It allows several antennas to be applied to transmit and receive ends in a MIMO system. Several pioneering works were carried out on MIMO systems (Winters 1987, Foschini and Gans 1998; Telatar 1999). The response from the channel is now a channel matrix  $H$  and can be expressed as (1948) and Winters (1987): Winters:

$$\begin{bmatrix} h_{11} & \dots & h_{1M_R} \\ \vdots & \ddots & \vdots \\ h_{M_T 1} & \dots & h_{M_T M_R} \end{bmatrix} \quad (3)$$

Where  $r$  is the number of orthogonal sub channels (i.e., rank) and  $\lambda_i$  is the Eigenvalues of the matrix  $HH^H$  (if  $M_T < M_R$ ) or  $H^H H$  (if  $M_T > M_R$ ).  $(\bullet)^H$  denotes the conjugate transpose (or Hermitian) operator. Eq. 5 can reveal that the high data rate signal of a MIMO system is achieved by providing multiple streams between transmitters and receivers with the same operating frequency channel.

## 2.1 Multiple-Antenna Performance Evaluation

A multi-antenna system can function in a rich scattering situation in different or MIMO schemes according to the SNR level. When the SNR is low, diversity can be used to fight fading. All antennas will be sent to the transmitter (or receiver) (Or receive) on the same channel the same signals. Since there is no correlating between transmitting (or receiving) antennas, the possibility for all antennas suffering from the deep fading is small. The reliability of the wireless connection can therefore be improved. In the high SNR region, the multi-antenna system functions as a MIMO system and uses fading to provide multiple uncorrelated channels. The various data can be transmitted simultaneously through various channels at the same operating frequency. The maximum data rate can therefore be achieved. The figure of metrics for multiple antenna systems is discussed in this chapter.

This helps to assess the diversity and performance of MIMO. Details of the antenna parameters (impedance bandwidth, gain, radiation pattern, efficiency, etc.) are not discussed, but can be found in Balanis (2005). Correlation Radiation pattern correlation coefficient calculation The relationship between multiple antenna systems is used to describe how independent Through various antenna ports.

Vaughan and Andersen (2003) provided the complex correlation coefficient:

$$\rho_c = \frac{\int \left( X_{PR} \cdot E_{\alpha} E_{\beta}^* P_{\alpha} + E_{\beta} X_{PR}^* P_{\beta} \right) d\Omega}{\sqrt{\int \left( X_{PR} \cdot E_{\alpha} E_{\alpha}^* P_{\alpha} + E_{\alpha} X_{PR}^* P_{\alpha} \right) d\Omega} \sqrt{\int \left( X_{PR} \cdot E_{\beta} E_{\beta}^* P_{\beta} + E_{\beta} X_{PR}^* P_{\beta} \right) d\Omega}} \quad (13)$$

Where  $E_{\alpha}$ ,  $E_{\beta}$  and  $E_{\alpha} E_{\beta}^*$  are embedded in a multi-antenna system,  $E_{\alpha}$  is the complex electrically-field patterns of two antennas  $X$  and  $Y$ . In fading Rayleigh the coefficient of envelope correlation becomes  $j2$ . The thumb rule for good diversity /The performance of the MIMO is  $S < 0.5$ . In Eq. 13, the correlation is also shown to be a parameter over some wireless circumstances. The correlation can be affected by antenna element distance, antenna directory, ground plane (or chassis), Q-factor, etc. in a real multi-antenna system.

## 2.2 S-parameters and radiation efficiency correlation coefficient calculation

The correlation coefficient can also be estimated from S-parameters in a lossless MIMO antenna system (Blanch et al. 2003). The upper limit of correlation can be calculated on the basis of the radiation efficiency (Hallbjorner 2005) (Eq. 14). Li et al. (2013) authors use a circuit-based equivalent method for determining correlations in loss antenna arrays. The equal circuit is shown in Fig. 1, where the loss is simulated by a loss component. Compared with the Hallbjorner (2005) and Li et al methods, a more precise correlation estimate can be obtained (2013).

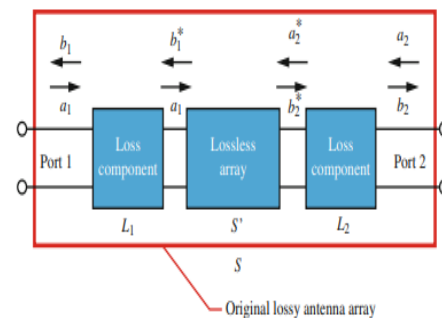

Fig. 2 Correlation coefficient calculation from S-parameters and radiation efficiency

$$|\rho_{ij}|_{\max} = \frac{\left| \frac{-S_r^* S_{ij} - S_p^* S_{ij}}{\sqrt{(1 - |S_{ii}|^2 - |S_{jj}|^2)(1 - |S_{ii}|^2 - |S_{jj}|^2)} \eta_i \eta_j} \right|}{\sqrt{\left(\frac{1}{\eta_i} - 1\right)\left(\frac{1}{\eta_j} - 1\right)}} \quad (14)$$

### 3. MIMO Performance

MIMO Capacity In the section MIMO in Wireless Communications, it has already been discussed that without the channel state information (CSI) at the transmitter, the power will be equally allocated to the transmitter, and the channel capacity of MIMO systems can be expressed by Winters (1987):

$$C_{\text{equal power}} = \sum_{i=1}^r \log_2 \left( 1 + \frac{E_t}{N_0 M_T} \lambda_i \right) \quad (18)$$

Where  $r$  is the number of orthogonal sub channels (i.e., rank) and is the eigenvalues of the matrix  $\mathbf{H}\mathbf{H}^H$  (if  $M_T < M_R$ ) or  $\mathbf{H}^H\mathbf{H}$  (if  $M_T > M_R$ ).  $(\bullet)^H$  denotes the conjugate transpose (or Hermitian) operator. If the CSI is available at the transmitter, the power allocation can be optimized by a water filling algorithm to the stronger sub channels rather than the weaker ones (Vaughan and Andersen 2003):

$$C_{\text{water filling}} = \sum_{i=1}^r \log_2(\lambda_i \cdot D) \quad (19)$$

and

$$D = \frac{1}{\lambda_i} + \mu \quad (20)$$

#### 3.1 Efficiency in Multiplexing

In order to evaluate MIMO performance in a simple way, Tian et al. introduces multiplexing efficiency (ME) or  $\xi_{\text{mux}}$  (2011). It has been defined as the power penalty of a realistic multi-antenna system for achieving that capacity as against an ideal antenna system with total efficiency of 100 percent and zero correlation (Tian et al. 2011). Tian et al. (2011) can express ME by assuming a high SNR and isotropic environment (i.e. equal likelihood of impinging waves from any direction):

$$\eta_{\text{mux}} = \sqrt{\eta_1 \eta_2 (1 - |\rho_{e1}|^2)}, \quad (21)$$

Where  $\eta_1$  and  $\eta_2$  are the total efficiencies of the elements of the MIMO antenna. In a propagation channel with a Gaussian angle of arrival distribution (AoA) in Tian et al. given by Eq. 9 (2011), the MIMO multiplexing efficiency may also be provided. The following assumptions have been evaluated: The mean direction of incidence is indicated by  $\phi_0$  and  $\Theta_0$  (unlike the isotropic channel, the probability of impinging waves is not equal in all directions, but at AoA  $\phi_0$  and  $\mu_0$ , but the maximum is  $\pm 0$ , respectively). It is assumed that both the elevation and the azimuth have the same angle spread. Equal to 30 degrees. Furthermore, the analysis is restricted to channels with balance polarization, i.e.  $XPR = 1$ . Two ideal cross-polarized antennas give a zero correlation as a reference. The multiplexing efficiency depends on the mean incidence direction according to the above conditions. This situation involves mobile MIMO terminal and diversity antennas operating at low frequencies (less than 960 MHz). Moreover, the wavelength is comparable at low frequency band (700–960 MHz). With the size of the mobile chassis. The ground plane will become an effective radiator and have similar patterns of radiation on all MIMO/diversity elements. This would eventually degrade the performance of the multiple antennas. The low mutual connection also does not reflect the low correlation and high efficiency in this situation. It is also noted. The bandwidth requirement is one of the key issues in the compact MIMO antenna design. All antenna parameters like the matching of antenna impedance, antenna efficiency, the envelope correlation between antennas, the gain in diversity and multiplexing efficiency have their own bandwidths. The bandwidth of the single antenna element is mainly affected by basic small antenna limits such as size, material loading and Q value. The bandwidth will also be affected by the size of the antenna system, the antenna imbalance and mutual coupling of the antenna elements in multiple-antenna cases, however. The performance of several basic MIMO antennas is discussed in the section "Performances of some fundamental MIMO antennas." Furthermore, the interactions between the multiple antennas and users reduce the total efficiency and absorb some radiated / received power of the antennas by changing the resonant frequencies. The presence of the human body has a major impact on correlations and efficiency in various situations (speech mode, data mode, or reading mode). Further details are discussed in the section.

## 4. Performances of Certain Fundamental MIMO Antennas

### 4.1 Parallel Dipoles

There are two dipole elements parallel to each other, at a resonance frequency of 850 MHz, at a distance between  $0.1\lambda$  and at dipole antennas lengths of  $\lambda/6$ ,  $\lambda/3$  and  $\lambda/2$  (Fig. 2). The typically resonant dipole length is  $\lambda/2$ , and the matching networks on the microphone MIMO dipoles have been added to 850 MHz to adjust their resonant frequencies. Parallel MIMO dipole performance is shown in Fig. 3. The MIMO antenna performance is evaluated using 4 different parameters including S-parameters, efficiencies (radiation efficiency (RE) and overall efficiency (TE)), the envelope correlation coefficient (ECC), and the multiplex efficiency (MUX). The antenna impedance bandwidth is usually defined with a reflective coefficient S11 less than 6 dB. However, for MIMO applications, the bandwidth of the total efficiency must also be taken into account, that the efficiency is greater than 4 dB and that

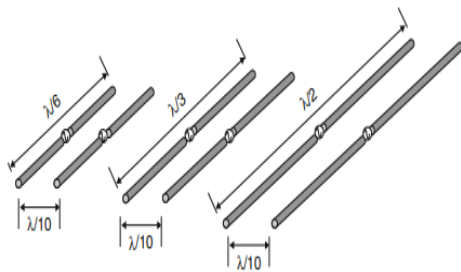

Fig. 4.1 Structures of fundamental MIMO dipole antennas

Envelope correlation coefficient bandwidth that is below 0.5. Fig. 3a shows that larger antenna volumes are capable of producing greater S11 bandwidths. Mutual connections (S21) are also available in larger antenna volumes. In general, lower. In Figure 3b, smaller dipole MIMO antennas have also lower antenna efficiency, a combined effect due to the strong mutual connection and the corresponding network. The total efficiency of  $\lambda/6$  is therefore always lower than  $\sim 4$  dB, and thus its bandwidth is zero

### 4.2 Coground Monopoles

In mobile terminals, monopole antennas are more popular than dipole antennas due to their smaller length of resonant and simple feeder structure. The MIMO performance of ideal  $\lambda/4$  MIMO monopoles with centre frequencies around 850 MHz is studied in this section. Strays are mounted on a large scale Round floor plane with radius greater than  $2\lambda$  and distance of separation approximately  $0.1\lambda$  shown in Fig. 8. Fig. 9 describes the S-parameter, total efficiency and coefficient of envelope correlation of coground monopoles. Due to the close position, the mutual coupling with this antenna configuration is fairly high and total efficiency on the resonant frequency is less than 2, dB. Like parallel MIMO dipole antennas, the coefficient of envelope correlations are mainly influenced by mutual dispersion effects (Zhang et al. 2013a). The effective bandwidth is 810 to 960 MHz for illustrated MIMO monopoles, which is better than  $\lambda/2$  dipole parallel MIMO, but worse than  $\lambda/2$  orthogonal MIMO dipoles.

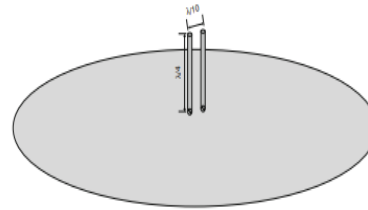

Fig. 4.2 The co-ground monopole antennas

## 5. Antenna Designs in LTE MIMO Applications

MIMO systems are an integral part of mobile terminals in present and future wireless telecommunications systems such as LTE and LTE Advanced. Several new channels are assigned to lower frequency bands in the LTE standards MHz 700–960. As stated in the section 'Compact MIMO Antenna Design Decoupling Techniques' the antenna elements in a MIMO antenna system should have low correlation and high overall efficiency to guarantee good MIMO performance in multiplexing. Contrary to higher frequency ranges, the lower frequency MIMO mobile antenna systems won't focus on reducing mutual connection but will explicitly improve the relationship and efficiency due to low radiation efficiency (Li et al. 2013). The wavelengths at the lower frequencies are much longer than at the higher frequencies and this poses new challenges for achieving good MIMO performance in mobile

terminals: (1) each element of the MIMO antenna must be redesigned to obtain

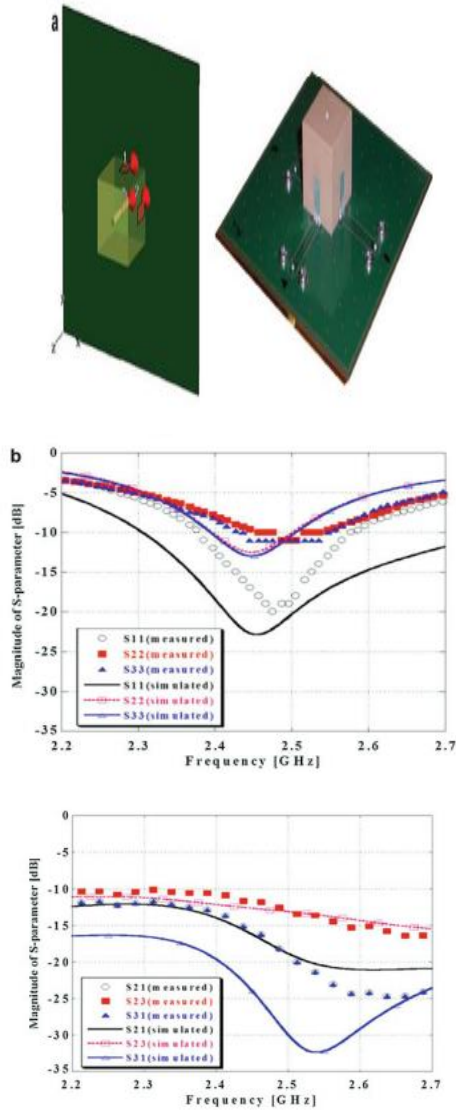

Fig.5.1 (a) Compact 3-port DRA MIMO antennas and (b) measured S-parameters

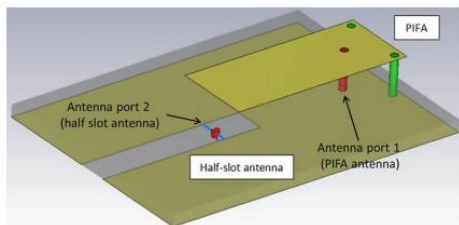

Fig. 5.2 Geometry of half-wavelength slot and PIFA antenna pair

A compact structure fitting into the device; (2) decorrelation structures should be tiny sufficiently and

function well; (3) MIMO elements and related structures should be more closely positioned, causing great correlation.

And (4) the chassis mode will be excited efficiently, which will make each MIMO element's pattern of radiation very similar, which will lead to a very high correlation. The LTE MIMO cellular antennas in the lower bands are reference values below 0, 5 and the total efficiency below 40 percent according to research, including field trials and mackereling (Ying 2012). A number of studies have been carried out recently to deal with those problems, including use of LTE MIMO single band neutralization line at Bae et al. (2010) and Park et al. (2009) or use of lower band networks at Park et al. (2011), Kim et al. (2011), and Lau and Andersen (2012). These methods can only be used for very small belt operations, however, and in practice will reduce the radiation efficiency significantly. More technologies to reduce correlations and improve efficiency in low-frequency bands will be discussed below (less than 1 GHz).

## 6. Chassis Mode and Orthogonal Chassis Mode MIMO Antennas

In Li et al. (2012b), the interactions between MIMO antennas and mobile chassis have been studied. The E-fields and H-fields of the fundamental mobile chassis characteristic mode are given in Fig. 22. The results reveal that the characteristic modes play an important role in determining the optimal placement of antennas. For example, if two electric antennas are put at the two ends of the mobile chassis, a very high mutual coupling between two antennas is expected. In mobile terminals, the orthogonal mode MIMO antennas can be realized by combining an electrical antenna (dipole) and a magnetic antenna (slot, loop).

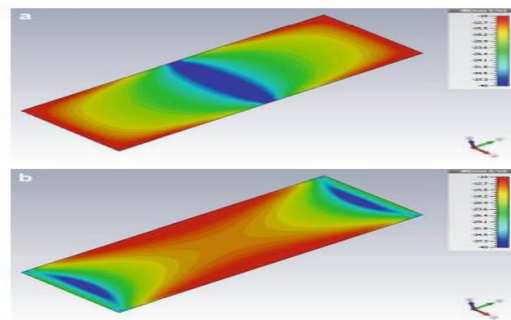
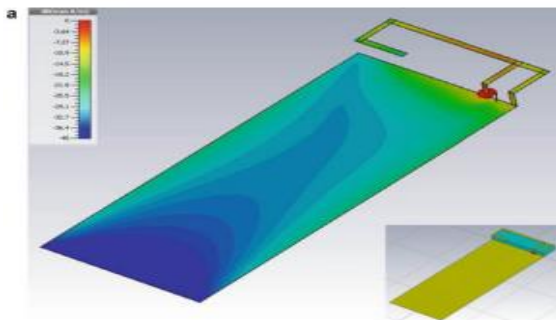

Fig. 6.1 Characteristic mode of mobile chassis: (a) E-fields, and (b) H-fields



## 6.2 Localized Mode

In some cases, when two electrical MIMO antenna elements are used in a mobile terminal, a good diversity and decoupling performance can be achieved by exciting different modes for different antennas. For example, Antenna 1 is exciting in chassis mode, whereas Antenna 2 is exciting in localized mode (Li et al. 2011). Typical directive antennas like patch, notch, and balanced dipoles are good candidates to be excited in localized mode. It shows the current distributions of a PIFA with different dielectric permittivity. With a higher dielectric permittivity, the current distribution on the PIFA is more localized. The radiation patterns of localized mode antenna will be different compared to the chassis mode antenna, thus the envelope correlation between the two antennas could be reduced. The trade-off of this design.



Would be imbalanced MIMO antenna structures. In Li et al. (2011), current distribution with different permittivity of a MIMO antenna configuration has been given, and the impact of localized mode on MIMO performance have also been presented.

## 6.3 Mutual Scattering Modes and MIMO Bandwidth Enhancement Diagonal Antenna Chassis

To achieve a correlation below 0.5 and a total efficiency higher than 4 dB per day MIMO Bandwidth Improvement has been proposed for broadband operations with low-frequency bands, mutual scattering modes (Zhang et al. 2012b, 2013a) and diagonal antenna chassis (Zhang et al. 2012c, 2013b, 2015a). For closely located MIMO antennas, the strong reciprocal dispersion effect is used to effectively decrease the MIMO antenna correlation coefficient (Zhang et al. 2012a, b). In general, MIMO antennas with high Q values have the strong mutual dispersal effect, in which impedance with lumped elements can be optimized. In Figure 25, the higher Q factor can provide a lower correlation with better total efficiency when two antennas are placed at the same extreme of the mobile terminal. Moreover, a MIMO antenna based on mutual dispersion was proposed for OTA applications in Zhang et al. (2013b). In combination with diagonal chassis mode, the low LTE band (less than 1 GHz) offers a better pattern diversity (Zhang et al. 2012c, 2013b, 2015a). The antenna element and the soil plane are seen as two arms of a dipole antenna when a terminal antenna operates at low frequency. Thus, the direction of the dipole antenna's radiation pattern is determined principally by the current ground plane distribution. The fact that the volume of the ground plane is much larger than the antenna element can be concluded. By moving the two MIMO double-element antennas in different corners of the earth, the diagonal chassis mode can be realized. The two MIMO elements can therefore form two dipole-like patterns of orthogonal radiation. It can be seen in figures 26 and 27 that the MIMO antennas placed have almost opposite patterns because of the effect of diagonal chassis mode.

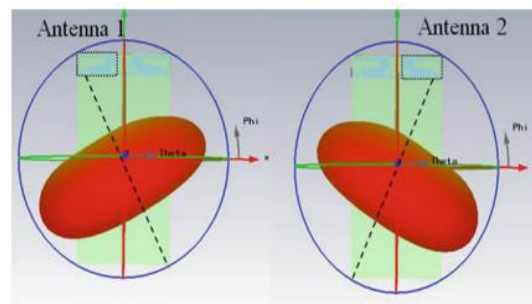



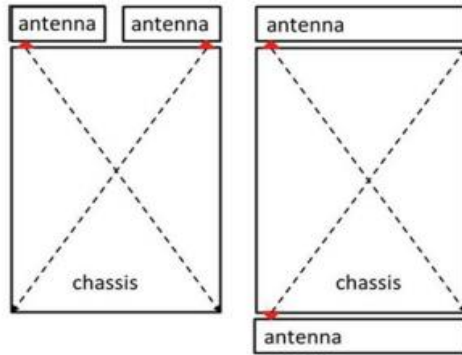

Fig. 6.3 Diagonal chassis mode in mobile terminals

Independently adjusted. In general, the two conformal scatterers can be printed outside or inside the telephone housing with the main PCB floors. It should be noted that the more distant the scattered can be thought of as a type of radiator. The ground plane helps enhance the bandwidth of the operating frequency. However, in real applications, hand effects must also be taken into account. Inserting a dispersor between two closely packed antennas can improve isolation by artificially creating an extra connecting path in which field cancellation occurs and therefore decreases the corresponding envelope correlation. In addition, dipole and slot antenna are complementary elements of electromagnetism, according to the Booker relationship (Chiu et al. 2013). The scattered design is therefore also suitable for metal chassis.

## 7. Multiantenna SAR and OTA Performance, Field Trial Body Effects on Compact MIMO Antennas in Mobile Terminals

Another important issue is the radiation performance of MIMO antennas in mobile terminals, including user effects. In the user case, test regulations for mobile terminals have been developed or are still in place. The cellular telecoms and Internet Association (CTIA)/The Wireless Association is an international organization based in the United States which serves wireless industry interests by lobbying government agencies and helps regulators (CTIA 2011). To date, in the OTA test of mobile terminals, two user cases were defined by CTIA which are the speech mode (head + manoeuvre) and data mode (single hand)

shown in Fig. 32. For the user case the correlation coefficient as well as the overall efficiency of MIMO terminal antennas is generally low. The significant loss of overall efficiency is mainly due to the antennas irradiation efficiency (body absorption) being mismatched and reduced. The mismatching can be solved by adjusting the operating frequency with lumped elements of the antenna, but it is not easy to compromise the fall in radiation efficiency. The loss of efficiency is generally related to the volume of antenna, antenna type and terminal volume. Larger antenna and terminal volume will help reduce losses, with a lower efficiency loss in magnetic antennas than electric antennas (loop, slot) (IFA, PIFA, etc.). Due to body dispersion and shadowing, the correlation coefficient is low. For a good MIMO reception, the body effect is a major concern. The loss of efficiency of MIMO terminal antennas will depend upon a number of factors, such as antenna location, frequency of operation, phone sizes etc., as shown in Fig. 33 (Zhao et al. 2013a; Zhang et al. 2013c, 2015b). Several methods were proposed in MIMO terminal antennas to prevent body loss. In Zhao et al. (2013) the hand body loss of the LTE mobile antenna can be significantly reduced through the introduction of a small space between human body and antenna in CTIA talk and data modes. An adaptive quad element MIMO antenna array has been designed in Zhang et al. (2015b) (Fig. 34). The body loss can be optimized and the performance of the MIMO improved by selecting the best two out of four elements when the terminal is held by the users.

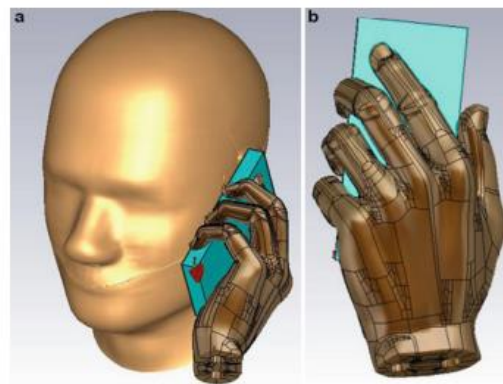

Fig.7 CTIA user cases: (a) talking mode and (b) data mode

## 8. LTE Field Trial at 700 MHz Band with Different MIMO Antenna Designs

Both mean effective gain and correlation for an LTE MIMO terminal determines the MIMO throughput performance. Antennas usually have relatively low correlation with frequency bands around 2 GHz and higher in a typical Smartphone. So the main thing The effort to achieve good MIMO performance is to design highly efficient, less coupling loss antennas within the frequency range discussed in the "Decoupling Techniques of Compact MIMO Antenna Designs" section. However, designing low correlation and low-connection MIMO antennas in low-frequency bands, particularly with 700 MHz bands, is a big challenge. In Sony's Mobile Research Laboratory and field trial with Ericsson Research, some detailed mockups in different correlation levels were built and tested. Figure 39 shows four different designs of MIMO antennas for typical 700 MHz smart phones. Design (a) has two top and bottom monopoles; the chassis mode is powerful and the correlation is therefore relatively high. Design (b) consists of a monopole and a notch in which the two antennas are arranged orthogonally. In this case, the correlation is low. Design (c) has a loop antenna placed where two ports are supplied with an antenna element. This is a design that has a very high correlation. Design (d) consists of a monopole chassis and a localized patch antenna and is found.

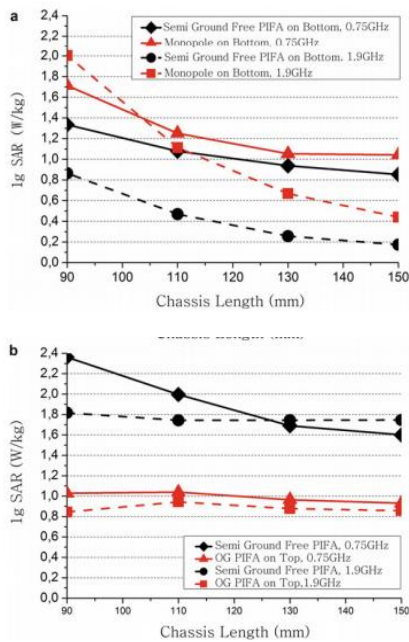

Fig. 8 Simulation SAR with different antenna type and different chassis length (a) bottom antenna (b) top antenna

The correlation is very low. The mock-ups have been tested and characterized in the Sony Mobile laboratory; the results are shown in table 5 (Fig. 40). Compared to reference antenna performance (separated orthogonal) It has been found that a compact MIMO antenna arrangement can also have a rather good MIMO performance. Even at 700 MHz the envelope correlation can be less than 0.5. Good antenna efficiency for both antennas is crucial in order to cover a wider LTE service area with good data quality Table 5 the measured MIMO antenna performance of four different mock-ups, and the field trial test results

	Mean gain of two antennas	Pattern envelope correlation	MIMO multiplexing efficiency	MIMO gain drop due to pattern correlation	Apparent diversity gain at CDF 1 % level	Field test: proportion of two streams for MIMO (separate dipole as reference) (%)
Separated dipoles	-5.5 dB	0	-5.5 dB	0	11.5 dB	100
Mock-up (a)	-5.6 dB	0.51	-7.2 dB	1.6 dB	9.5 dB	91
Mock-up (b)	-5.0 dB	0.17	-5.4 dB	0.4 dB	10 dB	95
Mock-up (c)	-5.5 dB	0.94	-11.6 dB	6.1 dB	6.5 dB	8
Mock-up (d)	-2.9 dB	0.06	-2.9 dB	0	11.5 dB	100

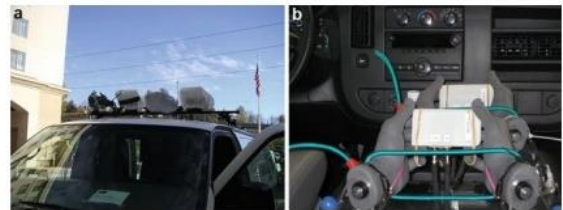

Fig. 8.1 (a) and (b) show the field trial in car roof and in the car, with and without hand phantoms (Courtesy of Ericsson AB) (Hagerman et al. 2011). In user case, the human body loading and absorption are the main impacts on the mean effective gain which determine the good data rate coverage service area; the correlation are generally low in user cases (Hagerman et al. 2011; Derneryd and Ying 2010).

**9. Conclusion** Some basic parameters characterizing diversity and MIMO antennas were discussed in this chapter. The performance and useful decoupling techniques of several key MIMO antennas were presented. Moreover, recent progress has been made. Technologies have also been reviewed for compact MIMO antennas, especially for mobile devices and terminals. For the mobile industry, the interactions between MIMO antennas and the human body and the several radio problems with SAR are important. It is shown that in an LTE MIMO field trial at 700 MHz the antenna impact can be addressed.

## References

1. Andrews MR, Mitra PP, de Carvalho R (2001) Tripling the capacity of wireless communications using electromagnetic polarization. *Nature* 1:316–318CrossRefGoogle Scholar
2. Bae H, Harackiewicz FJ, Park M, Jim T, Kim N, Kim D, Lee B (2010) Compact mobile handset MIMO antenna for LTE700 applications. *Microw Opt Technol Lett* 11:2419–2422CrossRefGoogle Scholar
3. Balanis CA (2005) *Antenna theory: analysis and design*, 3rd edn. Wiley-Interscience, HobokenGoogle Scholar
4. Bentsson E, Tufvesson F, Edfors O (2015) UE antenna properties and their influence on massive MIMO system performance. In: *European conference on antennas and propagation, Lisbon, accepted* Google
5. Blanch S, Romeu J, Corbella I (2003) exact representation of antenna system diversity performance from input parameter description. *Electron Lett* 39:705–707CrossRefGoogle Scholar
6. Bolin T, Derneryd a, Kristensson G, Plicanic V, Ying Z (2005) Two-antenna receives diversity performance in indoor environment. *IET Electron Lett* 10:1205–1206CrossRefGoogle Scholar
7. Chae SH, Yoon HS, Park SO (2008) the realization and analysis of pattern/polarization diversity in multiple input multiple output array. *Microw Opt Technol Lett* 3:561–566CrossRefGoogle Scholar
8. Chebihi A, Luxey C, Diallo A, Thuc PH, Staraj R (2008) A novel isolation technique for UMTS mobile phones. *IEEE Antennas Wirel Propag Lett* 7:665–668CrossRefGoogle Scholar
9. Chi G, Li B, Qi D (2005) Dual-band printed diversity antenna for 2.4/5.2-GHz WLAN application. *Microw Opt Technol Lett* 6:561–563CrossRefGoogle Scholar
10. Chiu CY, Yan J, Murch RD (2007a) Compact three-port orthogonally polarized MIMO antennas. *IEEE Antennas Wirel Propag Lett* 6:619–622CrossRefGoogle Scholar
11. Chiu CY, Cheng CH, Murch RD, Rowell CR (2007b) Reduction of mutual coupling between closely-packed antenna elements. *IEEE Trans Antennas Propag* 6:1732–1738CrossRefGoogle Scholar
12. Chiu CY, Yan JB, Murch RD, Yun JX, Vaughan RG (2009) Design and implementation of a compact 6-port antenna. *IEEE Antennas Wirel Propag Lett* 7:767–770CrossRefGoogle Scholar
13. Chiu CY, Liu, X, Gao F, Ying Z (2013) Reduction of envelope correlation on non-metallic and metallic chassis phones. In: *International workshop on antenna technology, Karlsruhe, vol 3, pp 31–34*Google Scholar
14. CTIA (2011) Test plan for mobile station over-the-air performance. Rev 3.1:184–189Google Scholar
15. Derneryd A, Ying Z (2010) Evaluation of different MIMO antenna designs in different correlation level for LTE 700 bands. Ericsson internal report 5Google Scholar
16. Diallo A, Luxey C, Thuc PL, Staraj R, Kossiavas G (2008) Enhanced two-antenna structures for universal mobile telecommunications system diversity terminals. *IET Microwaves Antennas Propag* 2:93–101CrossRefGoogle Scholar
17. Ding Y, Du Z, Gong K, Feng Z (2007) A four-element antenna system for mobile phones. *IEEE Antennas Wirel Propag Lett* 6:655–658CrossRefGoogle Scholar