



**ISSN: 2454-9940**



**INTERNATIONAL JOURNAL OF APPLIED  
SCIENCE ENGINEERING AND MANAGEMENT**

**E-Mail :**  
**editor.ijasem@gmail.com**  
**editor@ijasem.org**

**[www.ijasem.org](http://www.ijasem.org)**

## Growth of communication-related optical-fiber-monitoring technologies

J S S Ramaraju, Mahesh Gudivaka, R Mani Deepika,

### Abstract

*Due to its high data rate and capacity to transfer data over long distances, fibre optic technology has dominated the industry. It has been established that fibre optics is a far better technology over metal wires. Fiber optics are less susceptible to interference and have lower signal loss. Optical fibres can be employed in light transmission applications as they are waveguides. The optical fibre core is encased in an outer layer of glass or plastic that has a lower refractive index than the fibre core. To accomplish fine confinement of light within the waveguide, the entire internal reflection phenomenon is required. Most telecommunications networks employ fibre optics as their primary method of data transfer. (1) Chalcogenide glasses, fluor aluminate crystalline minerals, and fluor zirconate are used to make today's fibres.*

**KEYWORDS:** Fiber optics, silica, chalcogenide, fluor aluminate

### INTRODUCTION

Light pulses are sent over an optical fibre to transfer data from one point to another in fibre-optic communications. It's preferred to use fibre over electrical cabling when you need a high bandwidth, lengthy distance, or electromagnetic interference resistance. A local area network, a computer network or long distances can send voice, video, and telemetry utilizing this form of communication. Many telecommunications providers use optical fibre to deliver phone and Internet transmissions, as well as cable television signals. Using fibre-optic communication, Bell Labs researchers were able to achieve internet speeds of over 100 Peta bits per second on communication, fibre optics requires the following steps: To produce an optical signal from an electrical signal using a transmitter. An optical signal is obtained 4 Fibre optic transmission has several advantages, as stated below.

Fiber has a very high bandwidth compared to any other cable-based data transmission technology. Copper wires transfer less data per second than fibre optic connections. Distance: Optical cables have minimal power loss, allowing for greater signal transmission lengths compared to copper cables There is no way to prevent electromagnetic interference when working in the field. For this reason, fibre has an extremely low bit error rate (10 EXP-13). Fibre optic data transmission is virtually noiseless. In fibre optic transmission, light is used to transmit data or signals. As a result, by "listening in" to the electromagnetic energy "leaking" via the wire, there is no way to discover the data being communicated, ensuring absolute information security. Fiber optic cable has a very small diameter, which makes it ideal for use in small spaces. A single

Assistant Professor,<sup>1,2,3</sup>

Dept. of Electronics and Communication Engineering,

Bhimavaram Institute of Engineering and Technology, Bhimavaram, Andhra Pradesh, India.

E.mail id: [ramaraju404@gmail.com](mailto:ramaraju404@gmail.com), E.mail id: [mahesh.gudivaka@gmail.com](mailto:mahesh.gudivaka@gmail.com)

E.mail id: [ratnalamanideepika1@gmail.com](mailto:ratnalamanideepika1@gmail.com)

OM3 multimode fibre, for example, has a cable diameter of around 2mm, which is significantly smaller than coaxial copper cable. In fibre optic transmission, small size saves more space.

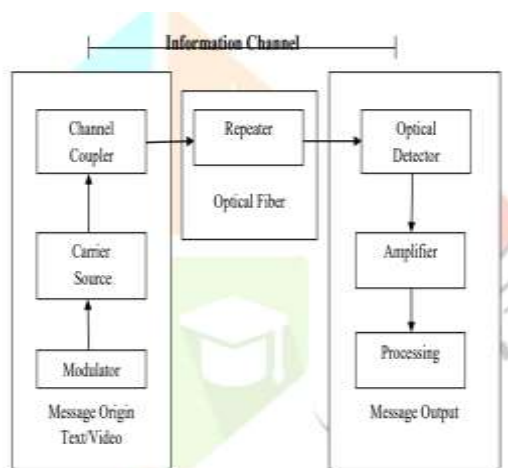

Figure 1: An Optical Fiber Communication System Block Diagram.

It is because fibre optic cable is comprised of glass or plastic that it is thinner and lighter than copper wire. As a result, they're lighter and easier to assemble. Fiber optic cable splicing is a labour-intensive operation that takes time. If they are twisted too much, they will also crack. A fibre cable's vulnerability to being cut or damaged during installation or construction is another concern. Due to all of these issues, it is difficult to install the software. Due to attenuation and dispersion as transmission lengths grow, more optical components such as EDFA will be required.

## RELATED WORKS

Optical fibre, copper-fibre half and halves, coaxial link, or turned pair would all be able to be utilized to associate client premises [15]. The expression "triple play" is ordinarily used to portray broadband administrations. Over a solitary broadband association, the help upholds phone, broadband Internet access, and TV. Present day ds innovation, like VDSL and VDSL2/2+, may convey higher than 50 Mb/s data transmission more than many meters between the client's home and the focal office. Ethernet, for instance, can convey 100 Mb/s across a brief distance of under 100 m. Copper innovation and PON are coupled in certain occasions to acquire better and lower arrangement costs. PON can interface the sign to the control, after which it tends to be conveyed to client homes through ds or Ethernet over a phone line or bent pair. These wire line access network advances, including curved pair, PON, fibre-copper half breed, ds, and coaxial link, will be examined long in the accompanying segments. PONs (Passive Optical Networks) appears to be a definitive response for fast access organizations. Optical

## Block Diagram of Optical Fiber Communication System

Fiber an optical fibre is a slender, adaptable, and straightforward wire that is utilized to communicate light.

- Light waves can't travel significant distances in air without bringing about misfortunes;
- Light waves can be controlled utilizing optical fibre to accomplish lossless light wave correspondence. Fiber optics has various benefits over copper line, including:
  - Increased data transmission: Optical filaments' high sign transfer speed gives substantially more data conveying limit. Multimode (MM) filaments regularly have transfer speeds of 200 to 600MHzkm, while single mode (SM) strands have transmission capacities of >10GHZkm.
  - Electromagnetic/Radio Frequency Interference Immunity: optical fibers are protected to electromagnetic impedance and produce no radiation;
  - Reduced cost, size, and weight: fibre optic connections are easier to present, require less channel space, and check 10% not as much as copper transports of tantamount sign passing on limit. Portions of a Fiber Optic Link To show how fibre optic applications work, we see four key sections of a fibre optic affiliation (Fig. 2). Optical Transmitter, Optical Fiber/Cable, and Optical Receiver are the three portions of an optical system.

- Transmitter The transmitter is obligated for changing over electrical to optical signs.

- Optical Fiber/Cable An optical fibre contains three concentric layers: Core: This internal part, involved silica or doped silica, is the fibber's light communicating zone; Cladding: This is the principal layer around the center. It's made of silica, albeit not a similar kind as the center. The primary non-optical layer around the cladding is the covering. At least one layers of polymer are typically present in a covering.

- Light Detectors are made up of numerous different types of photodiodes, the most prevalent of which are PIN and Avalanche Photo Diodes (APD). The light detectors reverse the light sources' operation, transforming optical energy back into electrical energy. PINs: create a single electron from each photon received, hence there

is no significant gain or signal strength improvement. Because APDs use a strong electric

field to accelerate electron transport in the semiconductor, they are more sensitive than PIN diodes.

## RESEARCH METHODOLOGY ON OPTICAL FIBER MONITORING IN COMMUNICATION SYSTEMS

Future optical fibre research directions in the twentieth century, it was wired transmission media that led to the invention of innovative transmission technologies, starting with copper twisted pairs in Morse Telegraphy and progressing to coaxial cable and eventually optical fibre (Fig. 4). However, when the demand for even higher capacities arose, conventional SMF's capacity constraints became evident. Improved or innovative transmission media are being sought with zeal. Multicore optical fibre and multimode optical fibre are two optical fibresbased possibilities for better transmission media. The former has many cores within a single clad, allowing for higher spatial density and transmission capacity. The latter has a topology that allows for multiple-input multiple-output (MIMO) transmission and multichannel propagation to enable high-capacity transmission. Next-generation research is also being carried out on the prospect of developing transmission media capable of transporting terahertz and ultraviolet light signals.

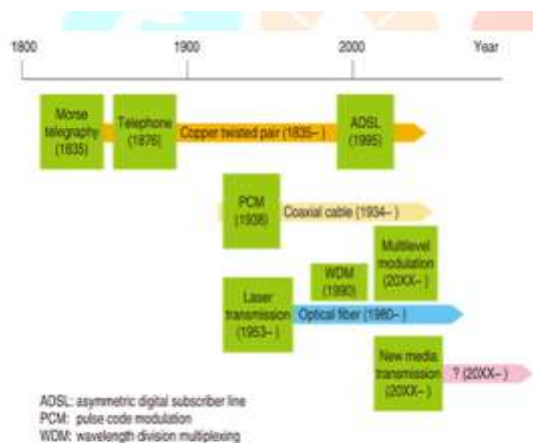
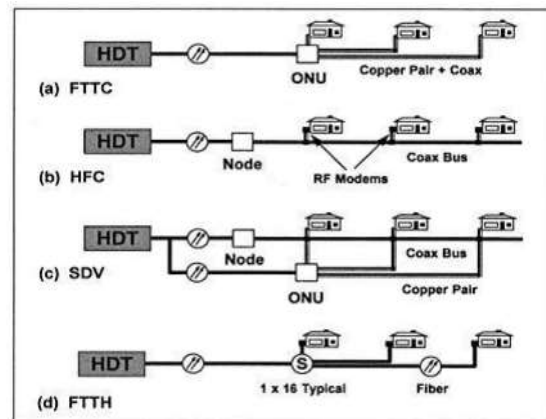

Figure 3 History of wired transmission media

The transmission capacity of high-density optical cables with decreasing diameters is increased by increasing the cable density. In contrast, the new, small-diameter, high-density optical cable under construction has an outside diameter of 15.8 mm and weighs 0.19 kilograms per meter, whereas the current cable has an outside diameter of 23 mm, and its weight is 0.45 kg/m. Installations will be very small due to the new wires. Density of certain multinational businesses' most sophisticated research product is more than 1.5 times higher than current levels. Nonetheless, the pursuit of

increasing fibre density is reaching its natural limits, and future cable R&D will likely focus on functional improvements.



The majority of recent FTTH progress has been made in Japan and Europe. Equipment has been built for NTT in Japan, as well as experiments in England, Belgium, Germany, and Denmark. FTTH is one of many "fullservice" access networks being developed by 10 network operators, two of which are from the United States. This new worldwide endeavour is encouraging. Figure 4 Telephone central offices or remote host digital terminals can be used for this purpose there are four major designs for delivering broadband information to the house (HDT). 10 000 residences are typically served by a typical central office From the HDT to the node or optical network unit (ONU), distances of 10 km or fewer are typical, as is the distance from these to the residence. The symbol is used to identify the fibers. a. It uses copper wire or coaxial cable to transmit data when the fibre is terminated at a unidirectional network unit (ONU) at the street curb in a neighbourhood, or at a major building.

This technology was employed in Germany for the large-scale OPAL installation. b. Coaxial cable is used from the node to the residence in the hybrid fibre-coax (HFC) architecture. Cable television technology is fairly similar to this one in that it carries analogue television channels, digital telephone, and data channels. c. An SDV design, which combines digital and analogy services, combines the best features of (a) and (b). There is a limited number of homes per ONU (4-24). d. In this structure, a passive optical splitter is used to share the long fibre line from the telephone office to the neighbourhood between 16 and 32 houses, therefore decreasing expenditures for each home. Aside from FTTH, there is no need for electricity to power the outside plant that connects the telephone company to your home or business. Light is used in these applications to achieve tasks that electronics cannot. Electronic technology, on the other hand, is great for most applications in information processing and sets a high bar of



performance. As a result, the use of optics to information processing is still a research issue in quest of a clear competitive advantage. The report's definition of optical information processing includes data connections, telecommunications switching, analogue and digital computing, and picture processing. The technology of choice for virtually all of these applications is silicon-based electronics. However, as more affordable and practical optical and optoelectronic technologies become accessible for use in appropriate systems, optics will become more significant. From the most advanced to the most hypothetical optical information processing devices are described in this section. Optical Data Lines Optical strands are a wonderful transmission medium, and they reign unchallenged in significant distance transmission joins, as exhibited in the main bit of this section. The possibilities for optics are quick growing over little distances, in neighbourhood (LANs) that interface PC workstations all through a ground or from one work area to another inside a structure, as costs tumble down and data transfer capacity needs keep on climbing. Optical information lines, then again, will become pertinent just when they become modest enough to rival hardware, particularly in low-end applications like associating work area PCs. Since optical information lines convey PC information and pictures, they should be very solid.

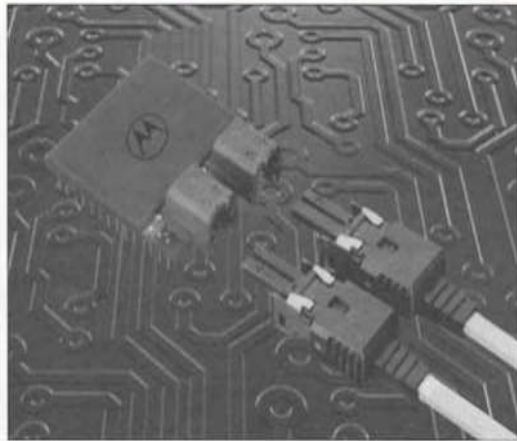

Figure 5 Optus, a Motorola system, is a good example of this.

Using arrays of lasers and detectors, Motorola's optical data connection package features a 10-fiber ribbon up to 100 meters long. In numerous datacom applications, embracing a serious level of parallelism, that is, utilizing varieties of lasers and identifiers coupled by fibre strips, lessens the expense per channel (see Figure 5 and Table 1). Equal optical connections limit link clog, board region, and data transmission requests on sources, indicators, hardware, and fibre, as well as bringing down costs. They also reduce the costly cost of electrical multiplexing by allowing numerous

alignments in a single production cycle. As a result, the packaging cost per channel is decreased, and electrical signal processing delays are eliminated.

Each laser has a fibre ribbon and a direct chip connected to it. Hewlett-Packard, Hitachi, and others have also created parallel optical data connections. By 2005, the usual price per duplex channel at 622 Mb/s is expected to drop to \$10 to \$15.

TABLE 1 Aspect of Selected Application Segments in Optical Communication

| Target Telecom           | Distance    | Data Rate      | Modem Cost Target |
|--------------------------|-------------|----------------|-------------------|
| Long-distance            | 5-100 km    | 0.6-2.5 Gb/s   | \$10,000          |
| Short distance           | 1-10 km     | 50-622 Mb/s    | 1,000             |
| Datacom high-performance |             |                |                   |
| Campus                   | 300-2,000 m | 200-1,000 Mb/s | 100               |
| Low cost                 |             |                |                   |
| Desktop                  | <100m       | <200 Mb/s      | 10                |
| Backbone                 | 100-500 m   | <200 Mb/s      |                   |

## Optical Networking and Switching

Light signals would remain light signals throughout a network made entirely of optical fibers. This is determined by the system's architecture. The most important technological problem is to define optics' capabilities so that it can play a crucial role in the assembly, management, and dispersion of a vast number of signal sources and destinations. The cost of switching is increasing as the cost of information transmission decreases. This makes switching an important problem and an important business. Today, a single fibre may completely fill the switching capacity of the biggest switch ever built. Because transmission costs are reducing rapidly, switching and networking will be the key system costs unless network topologies evolve to use longer fibre lengths between switches.

## Conclusion

Engineering, photonics, medicine, and telecommunications are just a few of the fields that have used optical fibre technology. Its performance, low loss, less interference, enhanced bandwidth, and intrinsic high data carrying capacity have attracted the attention of several investigations. Sand is a naturally abundant substance used to make optical fibres. Use of the sand fibre optic gyroscope to deploy novel sensor technologies and methods.

## REFERENCES

- [1] Sanxian Wen, Member, IEEE, Wenjun Liu, Yi Huang, Yuchen Liu, Manhua Luo, "Spun related effects on optical properties of spun silica optical fibres", DOI 10.1109/JLT.2014.2374839, *Journal of Lightwave Technology* 2015.
- [2] Jinxing Wen, Xinyi He, Jian Fei Xing, "All-Fiber OAM Amplifier With High Purity and Broadband Spectrum Gain Based on Fused Taper Vortex-Beam Coupler" *IEEE Photonics Journal*, Volume 6, Number 10, December 2018.
- [3] Tianxing Wang, Zhijun Yan, Qianqian Huang, Chuanhang Zou, Chengbo Mou "Mode-Locked Erbium-Doped Fiber Lasers Using 45° Tilted Fiber Grating" *IEEE Journal of Selected Topics in Quantum Electronics*, Year: 2018 | Volume: 24, Issue: 3.
- [4] Ming-junli, Xinchun, Daniel A. Nolan, Jiwang, James A. West, and Karl W. "Specialty fibres for optical communication systems," *optical fibre telecommunication VA: components and subsystems*, 2008.
- [5] Koch, "Specialty fibres for optical communication systems," *optical fibre telecommunication VA: components and subsystems*, 2008.
- [6] Kwangand wangand "Analysis of beat noise in coherent and incoherent time pleading CDMA," by Kitayama. *J. Lightwave Tech.*, vol. 22, no. 2, pp. 2226-2235, 2004.
- [7] G.Grosche, B.Grosche, G.Grosche, G.Grosche, G.Grosche "Transmission of an optical carrier frequency across a telecommunication fibre link," Ipphardt, H.schnatz, G. Santrarelli, P.Lemomde, S. Bize, M.lours, in *proc. Baltimore: CLEO*, 2007.
- [8] G.Avdikos, G.Papadakis, and Dimitriou, "Overview of the Application of the High-Altitude Platform (HAP) System in Future Telecom Networks," in *Proc. This is the tenth signal procedure. 1-6, Space Commons*, 2008.
- [9] Pasu Kaewplung and Tuptim Angkacw, *Feasibility of 100-Gb/s 10000-km Single-Channel Optical Transmission Using Midway Optical Phase Conjugation with Third-Order Dispersion Compensation*, *IEEE Photonics Technology Letters*, Vol.13, No.4, April 2001.
- [10] Alfred W.T. Wu and Arthur J "Efficient Multi-wavelength Dynamic Model for Erbium-Doped Fiber Amplifier". *IEEE Journal of Quantum Electronics*, Vol.34, No.8, August 1998.
- [11] T YU, W M Reimer, and V S Grigoryan, "A Mean field technique for modelling wave length-division multiplexed systems", *IEEE Photonics Technology Letters*, vol. 12, no. 4, pp. 443-445, 2000.
- [12] Robert I. Killey, "Investigation of nonlinear distortion in 40 GB/s transmission with higher order mode fibre dispersion compensators", *Journal of light wave technology*, vol. 20, no. 12, December 2002, 2282-2285.