



**ISSN: 2454-9940**



**INTERNATIONAL JOURNAL OF APPLIED  
SCIENCE ENGINEERING AND MANAGEMENT**

**E-Mail :**  
**editor.ijasem@gmail.com**  
**editor@ijasem.org**



**[www.ijasem.org](http://www.ijasem.org)**

# IOT BASED ENERGY MONITORING SYSTEM FOR RESIDENTIAL ELECTRICITY CONSUMPTION

1.MR. MUKESH GILDA, 2.AKULA DIVYA SREE YADAV 3.MADDURI ASMITHA, 4.Peddola Meghana Reddy

5.G Archana

---

## OBJECTIVE

Home automation systems are developing rapidly, along with advances in electronic and information technology. One application of the home automation system that is growing more and more today is the smart home system to assist homeowners in monitoring and controlling the function of energy consumption automatically, remotely, and centrally

## PROBLEM STATEMENT

Based on the Ministry of Energy and Mineral Resources, electricity consumption in Indonesia increased year by year [1], one of the reasons for the increase in electricity consumption is the improvidence of home electricity usage. This happens because the time of use is often incorrect, ineffective, and lack of consumer awareness to save electricity, due to consumers cannot directly monitor the use of electrical energy they use.

## ABSTRACT

Now energy management is a major issue of whole world. Due to our mistakes, lots of energy is lost. We always forgot to switch off light, fan and other appliances that consumes electricity. In the developing nations, the attempt of gathering electricity usage and recognizing illicit usage of power is a troublesome and tedious undertaking which requires abundant human resources. The network of smart home system is powerless against theft. The goals of undertaking are the measure of energy being utilized by the business. Industry, home, hospital etc. just as giving suggestion through IOT. This Smart Energy Meter Billing System will detect the cause of energy loss in our home, residential building etc. here we are using a wireless Technology to control home loads. And also, we are checking energy meter theft detection by using energy meter with help of LDR Sensor.

---

## INTRODUCTION ;

Electric energy utilization manages the use of electric energy for home-grown, horticultural, modern purposes. All out power consumed by total populace in 2012 was assessed to be 20,900 Terawatt-hour (TWh). Worldwide power request rose by 4% increment in 2018 and it's the most elevated beginning around 2010. Despite the fact that the larger part interest for electric power is met by atomic sustainable power sources, there is an expansion in arrangement of coal, internal combustion plants which drives CO<sub>2</sub> discharge undeniably. The complete energy created in India expanded from 154.7 GW to a surprising 345.5 GW in 2018, making the world's third biggest electric energy

maker falling behind China, United States. No matter what this amazing advancement, India faces a far reaching interest for power. International Energy Agency estimates that interest for power in India will significantly increase somewhere in the range of 2018 and 2040. Electric energy interest in India expanded to 65 TWh in 2018 which is in lower rate contrasted with the earlier year; the increment of force request comes from structures, where cooling is most extreme essential. This undertaking targets bringing down the use of power by productive unique power the executives utilizing IoT.

---

ASSISTANT PROFESSOR<sup>1</sup>, UG SCHOLAR<sup>2,3,4,5</sup>

g.mukesh@sphoorthyengg.ac.in , divya.akula2323@gmail.com , [asmitha.reddy0116@gmail.com](mailto:asmitha.reddy0116@gmail.com)  
peddolameghana@gmail.com , archana.sony329@gmail.com

DEPT. ELECTRONICS AND COMMUNICATION ENGINEERING SPHOORTHY ENGINEERING COLLEGE  
HYDERABAD, INDIA

---

## SYSTEM ANALYSIS

### EXISTING SYSTEM

In existing systems, we have power consuming details and the user can check the power consumption but it doesn't have adding of additional units of power and controlling of loads from long distances.

### DRAWBACKS:

In the existing system meter tampering can be done easily

Manual Work is more and errors may happen

### PROPOSED SYSTEM:

The proposed system presents friendly expense design and implementation of home load control by maintaining of power consumption. The energy meter is connected to Raspberry Pi. When the energy meter started then the LDR will read the units and displays it on LCD. The values are sent to cloud and if the units are consumed then SMS will be sent using GSM.

### BLOCK DIAGRAM

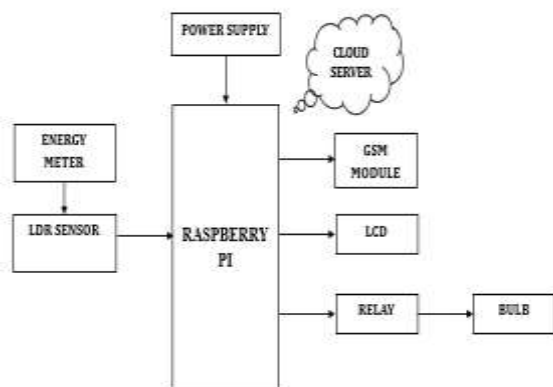

### RPI-PICO

A Raspberry Pi Pico is a low-cost microcontroller device. Microcontrollers are tiny computers, but they tend to lack large volume storage and peripheral devices that you can plug in (for example, keyboards or monitors).

A Raspberry Pi Pico has GPIO pins, much like a Raspberry Pi computer, which means it can be used to control and receive input from a variety of electronic devices

Raspberry Pi Foundation is well known for its series of single-board computers (Raspberry Pi series). But in **January 2021** they launched their first micro-controller board known as **Raspberry Pi Pico**.

It is built around the **RP2040 Soc**, a very fast yet cost-effective microcontroller chip packed with a dual-core **ARM Cortex-M0+ processor**. M0+ is one of the most power-efficient ARM processor Raspberry Pi PICO board



Raspberry Pi PICO board

Raspberry Pi Pico is a small, fast, and versatile board that at its heart consists of **RP2040**, a brand-new product launched by Raspberry Foundation in the UK. It can be programmed using **MicroPython** or **C** language.

### Raspberry Pi PICO Board Layout

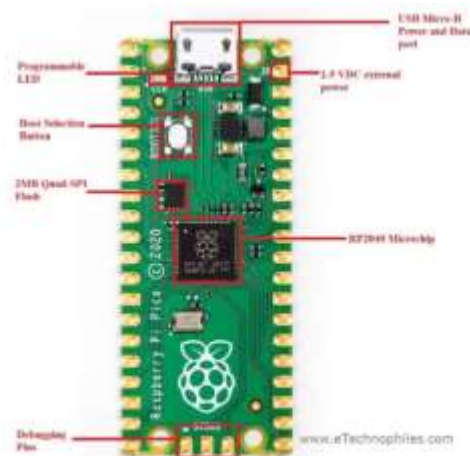

Raspberry Pi PICO Board Layout

Raspberry Pi Pico is made up of several components. The board layout given above shows some of them: **RP2040**

## Microcontroller, Debugging pins, Flash Memory, Boot selection button, programmable LED, USB port, and power pin

### LDR

A photo resistor or Light Dependent Resistor or CdS Cell is a resistor whose resistance decreases with increasing incident light intensity. It can also be referred to as a photoconductor. A photo resistor is made of a high resistance semiconductor. If light falling on the device is of high enough frequency, photons absorbed by the semiconductor give bound electrons enough energy to jump into the conduction band. The resulting free electron (and its hole partner) conduct electricity, thereby lowering resistance.

A photoelectric device can be either intrinsic or extrinsic. An intrinsic semiconductor has its own charge carriers and is not an efficient semiconductor, e.g. silicon. In intrinsic devices the only available electrons are in the valence band, and hence the photon must have enough energy to excite the electron across the entire band gap. Extrinsic devices have impurities, also called dopants, added whose ground state energy is closer to the conduction band; since the electrons don't have as far to jump, lower energy photons (i.e., longer wavelengths and lower frequencies) are sufficient to trigger the device. If a sample of silicon has some of its atoms replaced by phosphorus atoms (impurities), there will be extra electrons available for conduction. This is an example of an extrinsic semiconductor.



A Light Dependent Resistor (LDR, photoconductor, or photocell) is a device which has a resistance which varies according to the amount of light falling on its surface. They will be having a resistance of 1 MOhm in total darkness, and a resistance of a 1 to 10 of kOhm in bright light. A photoelectric device can be either intrinsic or extrinsic.

### GSM

GSM (Global System for Mobile communications) is a cellular network, which means that mobile phones connect to it by searching for cells in the immediate vicinity. GSM networks operate in four different frequency ranges. Most GSM networks

operate in the 900 MHz or 1800 MHz bands. Some countries in the Americas use the 850 MHz and 1900 MHz bands because the 900 and 1800 MHz frequency bands were already allocated.

The rarer 400 and 450 MHz frequency bands are assigned in some countries, where these frequencies were previously used for first-generation systems.

GSM-900 uses 890–915 MHz to send information from the mobile station to the base station (uplink) and 935–960 MHz for the other direction (downlink), providing 124 RF channels (channel numbers 1 to 124) spaced at 200 kHz. Duplex spacing of 45 MHz is used. In some countries the GSM-900 band has been extended to cover a larger frequency range. This 'extended GSM', E-GSM, uses 880–915 MHz (uplink) and 925–960 MHz (downlink), adding 50 channels (channel numbers 975 to 1023 and 0) to the original GSM-900 band. Time division multiplexing is used to allow eight full-rate or sixteen half-rate speech channels per radio frequency channel. There are eight radio timeslots (giving eight burst periods) grouped into what is called a TDMA frame. Half rate channels use alternate frames in the same timeslot. The channel data rate is 270.833 kbit/s, and the frame duration is 4.615 ms.

### ADVANTAGES

1. It is not difficult to work.
2. Practical.
3. One more benefit of the prepaid framework is that the human blunders in taking meter readings and handling bills can be diminished generally.

### APPLICATIONS

- In Houses
- In Workplaces
- In Factories

### CONCLUSION

In this task, a productive unique power the executives framework for family consumables utilizing Internet of things is introduced, proposed work is made utilizing Raspberry Pi, and its related peripherals, the framework cautions the client once the current or voltage scopes to greatest, it closes down power

naturally with auto shut down element, resumes power once qualities become typical.

## REFERENCE

1. Nouby M. Ghazaly, M. M. A. . (2022). A Review on Engine Fault Diagnosis through Vibration Analysis . International Journal on Recent Technologies in Mechanical and Electrical Engineering, 9(2), 01–06. <https://doi.org/10.17762/ijrmee.v9i2.364>
2. Pawan Kumar Tiwari, Mukesh Kumar Yadav, R. K. G. A. . (2022). Design Simulation and Review of Solar PV Power Forecasting Using Computing Techniques. International Journal on Recent Technologies in Mechanical and Electrical Engineering, 9(5), 18–27. <https://doi.org/10.17762/ijrmee.v9i5.370>
3. Ghazaly, N. M. . (2022). Data Catalogue Approaches, Implementation and Adoption: A Study of Purpose of Data Catalogue. International Journal on Future Revolution in Computer Science & Communication Engineering, 8(1), 01–04. <https://doi.org/10.17762/ijfrcsce.v8i1.2063>
4. Chaudhary, D. S. . (2022). Analysis of Concept of Big Data Process, Strategies, Adoption and Implementation. International Journal on Future Revolution in Computer Science & Communication Engineering, 8(1), 05–08. <https://doi.org/10.17762/ijfrcsce.v8i1.2065>
5. Malla, S., M. J. . Meena, O. . Reddy, R, V. . Mahalakshmi, and A. . Balobaid. “A Study on Fish Classification Techniques Using Convolutional Neural Networks on Highly Challenged Underwater Images”. International Journal on Recent and Innovation Trends in Computing and Communication, vol. 10, no. 4, Apr. 2022, pp. 01-09, doi:10.17762/ijritcc.v10i4.5524.
6. A. Chawla, “Phishing website analysis and detection using Machine Learning”, Int J Intell Syst Appl Eng, vol. 10, no. 1, pp. 10–16, Mar. 2022.
7. M. Dursun and N. Goker, “Evaluation of Project Management Methodologies Success Factors Using Fuzzy Cognitive Map Method: Waterfall, Agile, And Lean Six Sigma Cases”, Int J Intell Syst Appl Eng, vol. 10, no. 1, pp. 35–43, Mar. 2022.