



**ISSN: 2454-9940**



**INTERNATIONAL JOURNAL OF APPLIED  
SCIENCE ENGINEERING AND MANAGEMENT**

**E-Mail :**  
**editor.ijasem@gmail.com**  
**editor@ijasem.org**

**[www.ijasem.org](http://www.ijasem.org)**

# VLSI DESIGN FOR CONVOLUTIVE BLIND SOURCE SEPARATION

<sup>1</sup>G.Sanjeevarayudu,<sup>2</sup>S.Priyanka,<sup>3</sup>G.Rukmini Devi,<sup>4</sup>Eragam Reddy Siva Priyanka

<sup>1,2,3</sup>Assistant Professor,<sup>4</sup>Student

Department of ECE

Gouthami Institute Of Technology & Management For Women, Proddatur, Ysr Kadapa, A.P

## ABSTRACT:

Blind source separation (BSS) is a fundamental technique in signal processing that is used in a variety of domains, including picture, audio, and biological signal processing. Because it attempts to separate mixed sources in situations where the mixing process is defined by convolution, convolutive BSS is an exceptionally challenging task. This work offers a novel VLSI (Very Large Scale Integration) design specifically for convolutive blind source separation, aiming to meet the demands of real-time and efficient processing in applications such as echo cancellation, audio source separation, and speech enhancement. The recommended VLSI architecture uses state-of-the-art algorithms and hardware advancements to achieve convoluted BSS with high accuracy and low latency. It integrates multiple processing elements, each responsible for identifying and separating the unique source signals

from the mixture under observation. These processing elements use sophisticated signal processing methods and adaptive filtering techniques to iteratively refine source estimations, improving separation efficiency even in the face of time-varying mixture conditions. Important components of the VLSI design include parallel processing units, adaptive parameter tuning, and memory-efficient data structures. It is suitable for a range of real-world applications since it can manage different volumes of inputs and adjust to different computing requirements. The experimental results demonstrate the effectiveness and efficiency of the proposed VLSI architecture in convolutive BSS settings, as well as its real-time separation of mixed sources with excellent signal quality. Because of its scalability and endurance, the hardware design is a valuable tool for signal processing systems that need to

extract meaningful source information from complex mixes.

Keywords: BSS, VLSI, memory, and high efficiency.

## I INTRODUCTION

Blind source separation (BSS) is a pivotal signal processing technique with a multitude of applications in fields such as audio processing, telecommunications, biomedical engineering, and more. It involves the separation of mixed source signals when the mixing process is not known a priori. One particularly complex and challenging variant of BSS is convolutive blind source separation, where sources are mixed through convolution, simulating real-world scenarios like acoustic environments with multiple sound sources and reflections. Convolutive BSS has gained immense importance in applications such as speech enhancement, audio source separation, acoustic echo cancellation, and many others. It presents unique challenges due to the time-varying nature of the mixing process, which requires sophisticated algorithms and efficient hardware implementations to achieve real-time separation. This paper focuses on addressing the challenges posed by

convolutive BSS through the development of a specialized Very Large Scale Integration (VLSI) architecture. VLSI design plays a critical role in enabling the efficient and rapid execution of complex signal processing tasks, making it an ideal platform for convolutive BSS systems that require both accuracy and real-time capabilities. The aim of this paper is to present a novel VLSI design tailored to convolutive BSS scenarios. This design incorporates advanced signal processing algorithms, parallel processing elements, memory-efficient data structures, and adaptive parameter tuning to efficiently separate mixed sources. By leveraging these features, the proposed VLSI architecture seeks to enable real-time separation of sources from convoluted mixtures, addressing the pressing demand for high-performance BSS solutions in various practical applications. In the subsequent sections, we will delve into the architectural details, algorithmic approaches, and experimental results of the VLSI design for convolutive blind source separation. By the end of this paper, readers will gain a comprehensive understanding of the capabilities and potential impact of this VLSI solution in advancing signal

processing systems, particularly in scenarios involving convolution-based mixing.

Blind source separation is a kind of a filtering process used to separate different sources from the mixed signals in which most of the information about sources and mixed signals is not known. This restriction makes the blind source separation a challenging task. Blind source separation becomes a very important research topics in a lot of fields such as audio signal processing, biomedical signal processing, communication systems and image processing. Simple version of mixing process is one in which without filtering effect instantaneous mixing occurs. Convolutional mixing process should be done for the audio source passing through a filtering environment before arriving at the microphones and in order to recover the original audio source convoluted blind source separation should be done. One of the conventional methods is Independent component analysis (ICA) which is used to solve the CBSS problem. Major drawback of software implementation using this technique is often highly computational intensive and more time consuming process. Providing hardware solutions

for ICA-based blind source separation has drawn considerable attention because of the hardware solution achieves optimal parallelism. An analog BSS chip can be designed using above-and-sub threshold CMOS circuit techniques which integrates an i/o interface of analog, weight coefficients and adoption blocks.

## II LITERATURE SURVEY

Separating brain imaging signals by maximizing their autocorrelations is an important component of blind source separation (BSS). Canonical correlation analysis (CCA), one of leading BSS techniques, has been widely used for analyzing optical imaging (OI) and functional magnetic resonance imaging (fMRI) data. However, because of the need to reduce dimensionality and ignore spatial autocorrelation, CCA is problematic for separating temporal signal sources. To solve the problems of CCA, "straightforward image projection" (SIP) has been incorporated into temporal BSS. This novel method, termed low-dimensional canonical correlation analysis (LD-CCA), relies on the spatial and temporal autocorrelations of all genuine signals of interest. Incorporating both spatial and temporal information, here we introduce a

"generalized timecourse" technique in which data are artificially reorganized prior to separation. The quantity of spatial plus temporal autocorrelations can then be defined. By maximizing temporal and spatial autocorrelations in combination, LD-CCA is able to obtain expected "real" signal sources. Generalized timecourses are low-dimensional, eliminating the need for dimension reduction. This removes the risk of discarding useful information. The new method is compared with temporal CCA and temporal independent component analysis (tICA). Comparison of simulated data showed that LD-CCA was more effective for recovering signal sources. Comparisons using real intrinsic OI and fMRI data also supported the validity of LD-CCA. Online blind source separation (BSS) is proposed to overcome the high computational cost problem, which limits the practical applications of traditional batch BSS algorithms. However, the existing online BSS methods are mainly used to separate independent or uncorrelated sources.

Recently, nonnegative matrix factorization (NMF) shows great potential to separate the correlative sources, where some constraints are

often imposed to overcome the non uniqueness of the factorization. In this paper, an incremental NMF with volume constraint is derived and utilized for solving online BSS. The volume constraint to the mixing matrix enhances the identifiability of the sources, while the incremental learning mode reduces the computational cost. The proposed method takes advantage of the natural gradient based multiplication updating rule, and it performs especially well in the recovery of dependent sources. Simulations in BSS for dual-energy X-ray images, online encrypted speech signals, and high correlative face images show the validity of the proposed method. This brief presents an efficient verylarge-scale integration architecture design for convolutive blind source separation (CBSS). The CBSS separation network derived from the information maximization (Infomax) approach is adopted. The proposed CBSS chip design consists mainly of Infomax filtering modules and scaling factor computation modules. In an Infomax filtering module, input samples are filtered by an Infomax filter with the weights updated by Infomax-driven stochastic learning rules. As for the scaling factor computation module, all

operations including logistic sigmoid are integrated and implemented by the circuit design based on a piece wise linear approximation scheme.

### III PROPOSED SYSTEM

A proposed system for VLSI Design for Convolutional Blind Source Separation would involve the development of a specialized hardware architecture capable of efficiently and accurately separating mixed sources in real-time, particularly in scenarios where the mixing process is described by convolution. Here's an overview of the key components and features that such a system might include:

**1. Hardware Architecture:** The core of the proposed system is a custom-designed VLSI architecture optimized for convolutional blind source separation. This architecture would consist of dedicated hardware modules and processing units tailored to perform the necessary signal processing tasks efficiently.

**2. Parallel Processing:** To handle the computational demands of convolutional BSS in real-time, the VLSI system would incorporate parallel processing units. These units would enable simultaneous processing of multiple data

streams, accelerating the separation process.

**3. Adaptive Filtering:** Advanced adaptive filtering algorithms would be implemented in hardware to estimate and separate the individual source signals. These algorithms should be capable of adapting to changing mixing conditions, making the system robust in real-world scenarios.

**4. Memory Management:** Efficient memory management is essential to store intermediate results and filter coefficients. The system should include memory units optimized for low-latency access to data.

**5. Parameter Tuning:** The architecture may incorporate adaptive parameter tuning mechanisms that automatically adjust filter coefficients and other parameters based on the characteristics of the input signals and the mixing environment.

**6. Real-Time Processing:** Real-time performance is crucial for applications like audio source separation and speech enhancement. The proposed system should be capable of processing incoming data streams with low latency.

**7. Scalability:** The system's architecture should be scalable to accommodate



different numbers of sources and adapt to varying computational requirements.

**8. Noise Reduction:** To enhance the quality of separated signals, noise reduction techniques may be integrated into the system, especially in noisy environments.

**9. Evaluation and Testing:** The proposed system would undergo extensive testing and evaluation to validate its performance in various scenarios. Metrics such as Signal-to-Noise Ratio (SNR) and Separation Quality Metrics may be used for evaluation.

**10. Integration:** The VLSI system should be designed for easy integration into larger signal processing systems or devices, such as audio processors, medical equipment, or communication systems.

**11. Energy Efficiency:** To make the system suitable for portable and battery-powered devices, energy-efficient hardware design should be a consideration.

**12. Algorithm Flexibility:** While the focus is on convolutive BSS, the system may be designed to accommodate different blind source separation algorithms, offering flexibility for various applications.

The proposed system aims to provide an efficient and versatile solution for convolutive blind source separation, addressing the challenges posed by real-time processing, changing mixing conditions, and the need for high-quality source separation. It has the potential to enhance various applications, including speech enhancement, audio source separation, biomedical signal processing, and more.

#### IV METHODOLOGY

The proposed CBSS system is shown in the FIG. The CBSS chip mainly consists of two functional cores: Infomax filtering module and scaling factor computation module. Additionally, the Infomax filtering outputs are added with the help of two small carry-save adders (CSAs). The current prototype chip is used for two sources and two sensors by utilizing four Infomax filtering modules along with two scaling factor computation modules.

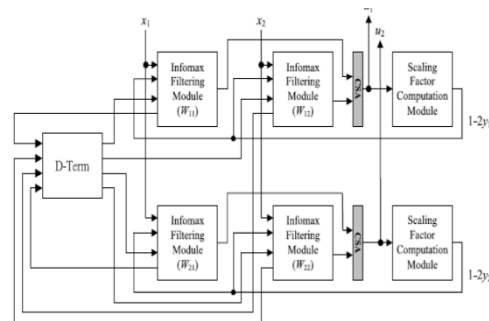

**Fig.1. Proposed model.**

The Infomax filtering module for the proposed system is shown in fig.3. In the fig. 1, the CBSS separation network contains four causal FIR filters. These filters are adaptive because stochastic learning rules which are derived from the Infomax approach will alter the tap coefficients and are thus referred to herein as the Infomax adaptive filter or the Infomax filter. The Infomax filtering module is exemplified with six taps. In the Infomax filtering module, an input sample passes through lower and upper register chains. These samples are multiplied with filter weights and scaling factors, respectively. The multiplication results of all of the taps are accumulated by a two-stage summation. The first stage adopts carry lookahead adders to generate the intermediate addition results for multiplication of every two successive taps. The above intermediate addition results are summed up by using a carry save addition scheme. A CSA(carry save adder) can accept more than two data inputs.

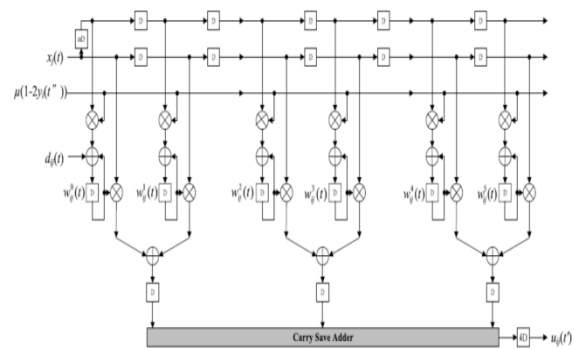

According to our numerical analysis, five line segments are sufficient to approximate with a negligible error. Let  $l_{si}$ ,  $i = 1, 2, \dots, 5$  denote the  $i$ th line segment, and  $c_i$  represent the connected point between two consecutive line segments. To implement the line-segment approximation, the circuit design for scaling factor computation is to calculate single variable linear equations. For the equation of  $l_{si}$  which corresponding to  $m_i(n) = a_i n + b_i$ ,  $i = 1, 2, \dots, 5$ , where  $n = u_i(t)$ . As the slopes of  $l_{s1}$  and  $l_{s5}$  are the same, these two line segments share the equation parameters  $a_1$ . In the same manner, line segments  $l_{s2}$  and  $l_{s4}$  share the equation parameters  $a_2$ . Furthermore, according to the symmetry in Fig. 5, the bias used for line segment  $l_{s5}$ , e.g.,  $-b_1$ , is the negative of the bias  $b_1$  used for line segment  $l_{s1}$ . In addition, line segments  $l_{s4}$  and  $l_{s2}$  use biases  $-b_2$  and  $b_2$ , respectively. As for the  $d_{0ij}(t)$ , this study designs a Dterm unit to execute



$d_{ij}(t) = \text{cofactor}(w_{ij})(\det W_0) - 1$ . The architecture of the D-term unit is shown in Fig. The Dterm unit consists of a determinant circuit to find.

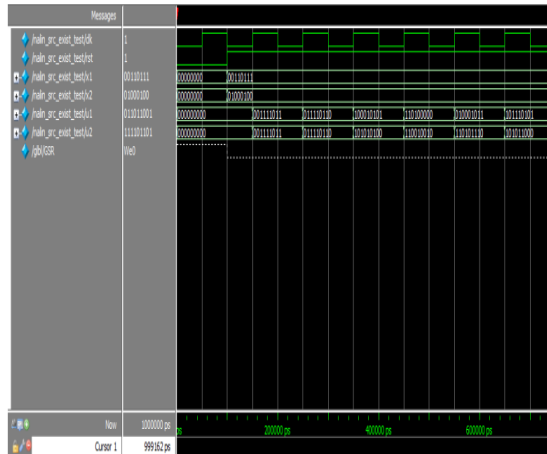

## CONCLUSION

This expeditious VLSI design process for CBSS has been around for some time. CBSS separation networks are computed using scaling aspect computation modules and a design based on the Info-max filtering system. With a die size of roughly 0.54 mm<sup>2</sup> by 0.54 mm<sup>2</sup>, the suggested ASIC device makes use of TSMC's cutting-edge 90-nm CMOS technology. The optimal operating voltage for a 1.8-V power supply is 100 MHz, which consumes just 54.86 mW of power. The proposed CBSS ASIC chip can be combined with other sound processing chips and ancillary components to construct a complete sound processing system, in addition to being used for reprocessing.

## REFERANCES

- [1] G. Zhou, Z. Yang, S. Xie, and J. M. Yang, "Online blind source separation using incremental nonnegative matrix factorization with volume constraint," *IEEE Trans. Neural Netw.*, vol. 22, no. 4, pp. 550–560, Apr. 2011.
- [2] M. Li, Y. Liu, G. Feng, Z. Zhou, and D. Hu, "OI and fMRI signal separation using both temporal and spatial autocorrelations," *IEEE Trans. Biomed. Eng.*, vol. 57, no. 8, pp. 1917–1926, Aug. 2010.
- [3] A. Tonazzini, I. Gerace, and F. Martinelli, "Multichannel blind separation and deconvolution of images for document analysis," *IEEE Trans. Image Process.*, vol. 19, no. 4, pp. 912–925, Apr. 2010.
- [4] H. L. N. Thi and C. Jutte, "Blind source separation for convolutive mixtures," *Signal Process.*, vol. 45, no. 2, pp. 209–229, Aug. 1995.
- [5] A. J. Bell and T. J. Sejnowski, "Blind separation and blind deconvolution: An information-theoretic approach," in *Proc. Int. Conf. Acoust., Speech, Signal Process.*, May 1995, vol. 5, pp. 3415–3418.
- [6] A. Hyvärinen and E. Oja, "Independent component analysis: Algorithms and applications," *Neural*

Netw., vol. 13, no. 4/5, pp. 411–430, May/Jun. 2000.

[7] M. H. Cohen and A. G. Andreou, “Analog CMOS integration and experimentation with an autoadaptive independent component analyzer,” *IEEE Trans. Circuits Syst. II, Analog Digit. Signal Process.*, vol. 42, no. 2, pp. 65–77, Feb. 1995.

[8] K. S. Cho and S. Y. Lee, “Implementation of InfoMax ICA algorithm with analog CMOS circuits,” in *Proc. Int. Workshop Independent Compon. Anal. Blind Signal Separation*, Dec. 2001, pp. 70–73.

[9] Z. Li and Q. Lin, “FPGA implementation of Infomax BSS algorithm with fixed-point number representation,” in *Proc. Int. Conf. Neural Netw. Brain*, 2005, vol. 2, pp. 889–892.

[10] H. Du and H. Qi, “An FPGA implementation of parallel ICA for dimensionality reduction in hyperspectral images,” in *Proc. IEEE Int. Geosci. Remote Sens. Symp.*, Sep. 2004, pp. 3257–3260.

[11] M. Ounas, R. Touhami, and M. C. E. Yagoub, “Low cost architecture of digital circuit for FPGA implementation based ICA training algorithm of blind signal separation,” in *Proc. Int. Symp.*

*Signals, Syst. Electron.*, 2007, pp. 135–138.

[12] K. K. Shyu, M. H. Lee, Y. T. Wu, and P. L. Lee, “Implementation of pipelined FastICA on FPGA for real-time blind source separation,” *IEEE Trans. Neural Netw.*, vol. 19, no. 6, pp. 958–970, Jun. 2008.