



**ISSN: 2454-9940**



**INTERNATIONAL JOURNAL OF APPLIED  
SCIENCE ENGINEERING AND MANAGEMENT**

**E-Mail :**  
**editor.ijasem@gmail.com**  
**editor@ijasem.org**

**[www.ijasem.org](http://www.ijasem.org)**

# IMPLEMENTING SPEED CONTROL OF INDUCTION MOTORS WITH ANDROID-BASED CYCLOCONVERTER TECHNOLOGY

<sup>1</sup>K.Kusal Kumar,<sup>2</sup>DR.P.H.K Prasad,<sup>3</sup>T.Lingaiah,<sup>4</sup>Balisetty Vennela

<sup>1,3</sup>Associate Professor,<sup>2</sup>professor,<sup>4</sup>Student

Department of EEE

G V R & S College of Engineering & Technology, Guntur, AP

**ABSTRACT**— The main objective of this paper is to design a model to control the speed of induction motor such as fan using android based smart phone. In this case, IOT can be used to remotely control the speed of an induction motor. The Android phone acts as a transmitter, while a WIFI module receiver connected to a PIC controller receives the signal. Each time, data is transmitted by the Android application (Blynk) in accordance with the written code, which is then carried out by the microcontroller to deliver the supply signal to the TRIAC through opto isolators. As a result, the received signal is used to control the power to a load linked in series with a TRIAC and to control the induction motor's speed. The host in this design is also given feedback. In order to display the speed to the user, a speed counter is attached to the induction motor's load. An android application (Blynk) is given control of the induction motor, and it displays the options for controlling the motor's speed. In this project, we use an AC-to-AC conversion, or cycloconverter, together with thyristors to control the speed of an induction motor in three steps.  $F$ ,  $F/2$ , and  $F/3$  are the three steps in question. Domestic appliances like washing machines and vacuum cleaners frequently employ single-phase induction motors. By employing a cycloconverter, we can get over the fundamental drawback of induction motors, which is that it is highly expensive to change their speed using other devices like VFDs (variable frequency drives). The PIC18F458 microcontroller is utilized in the functioning of an induction motor speed control to select the speed ranges ( $F$ ,  $F/2$ ,  $F/3$ , and  $F/4$ ). We employed thyristors i.e., TRIACS for its functioning since it is quite challenging to change the frequency of the AC supply at a low cost with great accuracy. The three-phase induction motor can also use this by connecting this in each phase.

**Keywords:** Cycloconverter, Induction Motor, Optocoupler.

## I. INTRODUCTION

By employing various techniques to regulate the operation of the cyclo-converter, which in turn regulates the performance of the motor, the speed management of an induction motor can be made simple and cost-effective. There are two ways to change the motor's speed: one is by altering the number of poles, and the other is by altering the frequency. The first way of controlling speed is not only inefficient, but it also limits the machine's ability to change its size and number of poles while it is in operation. The second approach can be used to solve these issues. This approach keeps the motor's size constant while allowing for frequency variation even while it is running. The Cyclo-converter serves as the frequency-changing gadget in this project. In order to convert constant voltage, constant frequency AC power to adjustable voltage, adjustable frequency AC power without a DC link, a cyclo-converter is a power electronic device. This method is among the easiest, most trustworthy, and least expensive ones. By adjusting the supply frequency with a cycloconverter, an induction motor can run at a variety of speeds.

Speed control of Induction motor play's important role in industries, there are various ways to control speed of motor but considering its efficiency, we proposed is designed to control the speed of a single-phase induction motor in three steps by using cyclo-converter technique by thyristors. AC motors have the great advantages of being relatively inexpensive and very reliable. Induction motors in particular are very robust and therefore used in many domestic appliances such as washing machines, vacuum cleaners, water pumps, and used in industries as well. The induction motor is known as a constant-speed machine, the difficulty of varying its speed by a cost-effective device is one of its main disadvantages. Cycloconverter have several important features, cycloconverter frequency can be varied by conduction period for each MOSFET. However, control of induction motor is challenging task, many authors have suggested different techniques for speed control of induction of induction motor. These include sliding mode control, fuzzy logic control and model predictive control and cycloconverter etc.

## II. LITERATURE SURVEY

Richa Gajbhiye et al., [1] "Speed Control of Induction Motor Using Single Phase Cycloconverter" In various application of electrical energy especially in industrial areas there are two types of current, Direct Current and Alternating Current are used. Generally fixed voltage, constant frequency single phase or three phase AC is easily available, yet for different applications various type of magnitudes or frequencies are essential. The project is designed to control the speed of a single-phase induction motor in three steps by using cycloconverter technique by thyristors. AC motors have the great advantages of being relatively inexpensive and very reliable. Induction motors in particular are very robust and therefore used in various industries like rice mill, shipping industries, etc. The induction motor is known as a constant-speed machine, the difficulty of varying its speed by a cost-effective device is one of its main disadvantages. As the AC supply frequency cannot be changed, so this project uses a thyristor controlled cyclo-converter which enables the control of speed in steps for an induction motor. This project is used to control the speed of induction motor by using SCR based cyclo-converter, here we used single phase induction motor which is generally applicable in various industries. By using SCR based cyclo-converter we can control the speed of AC motors, by using the V/F control method

S. V. THIGALE et al., [2] "Speed control of Induction motor using Cycloconverter with thyristor" Traditionally we use the converter and inverter to vary the AC supply frequency (i.e., it converts AC to DC by using converter and then inverter for DC to AC) to change the frequency which is very costly and complicated. Due to this switching of AC to DC and DC to AC the noise produces also the harmonics creates so the sensitive electronic devices may get damaged, if the input and output

waveforms is small then subharmonics also get produced and this limitation is overcome by using the cycloconverter i.e., Intermediate DC stage is not used in this conversion.

The Cycloconverter for the ease of operation. Cycloconverter means to convert the AC supply frequency from one input frequency to another output frequency. Cycloconverter is used for high power applications for driving Induction and synchronous motor. So, cycloconverter is used for providing a variable frequency due to its 4-quadrant operation. Intermediate DC stage is not used in this conversion. In cycloconverter power flow is bidirectional

ABHIJIT MULE,[3]" Android based speed control of induction motor" For the improvement of quality product, many industrial applications require adjustable speed and constant speed due to rapid advance in automation and process control. In recent technology, various alternate techniques are available for the selection of speed drive system. Up to the 1980's the dc motor was the choice for variable speed drive application. In past few years there has been a great demand in industry for adjustable speed drives. Fan, pump, Compressors, domestic applications and paper machines etc. In this area DC motor was very popular but having many disadvantages. So, the microcontroller transformed research and development toward control of ac drive. When the three-phase supply is not available for domestic and commercial application, there we are using single phase induction motor which is one of the most widely used type of low power motor in the world. There are various methods for controlling the speed of AC motors. One of the methods is to vary frequency and voltage of motor. One very nice example is fan regulator in which a fan motor is an AC motor used and its speed is varied using TRIAC method. In our project, the speed of induction motor is controlled with the help of android application that comes under wireless technology. Android application use here as a transmitter and remote control in order control the speed of induction motor with the help of Bluetooth as a receiver. The speed of the motor is counted with the help of a speed counter and it is displayed to the user.

B. SAI SINDURA et al., [4]" Speed Control of Induction Motor using Cycloconverter" Speed control of induction motor is necessary in industrial applications. There are several methods for the speed control of induction motor. Cyclo-converters are used in very large variable frequency drives with ratings from few megawatts up to many tens of megawatts. A cycloconverter is controlled through the timing of its firing pulses, so that it produces an alternating output voltage. It can also be considered as a static frequency changer and typically contains silicon controlled rectifiers. The development of the semiconductor devices has made it possible to control the frequency of the cycloconverter according to the requirement and deliver a large amount of controlled power with the help of semiconductor switching devices like Thyristors, MOSFET's in order to get alternating output of variable frequency. The quality of the output waveform improves if more switching devices are used. Split-phase induction motors are widely used in many applications due to their energy efficient characteristics. Improvements in its performance mean a great saving in electrical energy consumption. Thus, a cycloconverter has the facility for continuous and independent control over both its output frequency and voltage. Cycloconverter eliminates the use of flywheel because the presence of flywheel in machine increases torsional vibration and fatigue in the component of power transmission system.

P. R. Lole et al., [5]" Speed Control of Induction Motor by Using Cyclo-converter" This paper is used to control the speed of the induction motor. The speed control of Induction Motor is simple and

can be made economical by using different methods to control the operation of Cyclo-converter which in turn controls the performance of motor. The speed of the motor can be varied in two ways, one is by changing the number of poles and the second method is by changing the frequency. The speed control through the first method is uneconomical and the number of poles can't be varied under running conditions and the size of the machine also becomes bulky. These problems can be overcome by the second method. In this method, the frequency can be varied under running conditions also and there is no change in the size of the motor. In this method, the frequency changing device is Cyclo-converter. A Cyclo-converter is a power electronic device used to convert constant voltage constant Frequency AC power to adjustable voltage adjustable frequency AC power without a DC link. In among all the methods this method is simple, reliable and economical. The various speed of induction motor is obtained by varying the supply frequency by using Cycloconverter.

### III. PROPOSED METHODOLOGY

Android based Speed control of induction motor using cycloconverter is shown in figure 1. The block diagram is divided into 6 major parts: The power supply, Microcontroller board, Cycloconverter board, zero crossing detector circuit, Wi-Fi module and single-phase AC induction motor. Block diagram of the project is shown in figure 1.

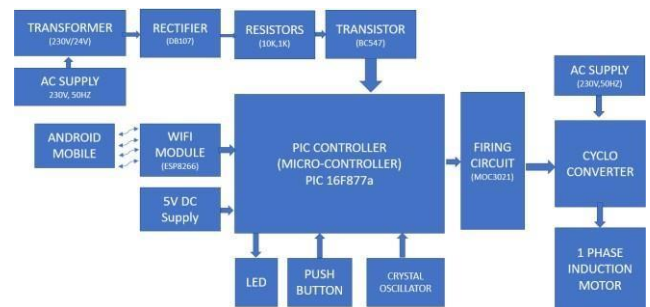

Fig 1. Block diagram

Induction motor used here is single phase capacitor start induction motor. Speed of an induction motor is given by formula  $N_s = 120f/P$ , using this formula the speed of an induction motor can be controlled in 2 ways i.e., either by changing number of stator poles or by changing the supply frequency. It is very difficult to change the poles of an induction motor once the construction is designed. Hence it is preferred to control the speed of an induction motor by changing the frequency.

Cyclo-converter is a device which changes fixed voltage and frequency into variable voltage and variable frequency. In this project, A step-down Bridge type cyclo-converter has been used. Hence, we obtain speeds only below the rated speed of induction motor. ESP8266 Wi-Fi module is used here in order to receive commands from the android mobile. The motor is operated in 4 different modes changing the frequency in 4 steps.

### IV. HARDWARE COMPONENTS



Fig.2 Hardware Design

#### A. POWER SUPPLY:

Here, in this project there are two types of supply voltages used (1)230V, AC which is supplied to cycloconverter and zero detector circuit, (2)5V, DC is used to supply microcontroller.

#### B. ZERO CROSSING CIRCUIT:

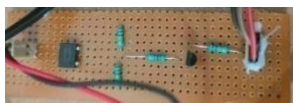

Fig.3 Zero crossing circuit

The opto isolator using for triggering of the triacs doesn't follow zero crossing. Hence, additional zero crossing circuit is used which consists of the transformer, rectifier circuit, resistors (voltage divider) and a transistor. Zero crossing circuit detector is required to notice when the input voltage crosses zero. Every time when supply voltage crosses zero, a +5V signal will be given to microcontroller. This signal is used to write the program. The zero-crossing circuit used in the project is shown in figure 3.

(i) **Transformer:** A 230V to 24V stepdown center-tapped transformer is used in the project. But only 12V is used in zero crossing detection circuit. Transformer used is shown in figure-4



Fig.4 Step down transformer

(ii) **Bridge rectifier:** A bridge rectifier IC is used to convert 12VAC into unidirectional current



Fig.5 Bridge rectifier

(iii) **Voltage divider circuit:** It will reduce this 12VDC in to a safe value to energize the gate of the transistor

(iv) **Transistor:** The emitter and collector of the transistor are connected to +5V and ground respectively. The transistor used is shown in figure 6. The gate will receive triggering every time the input voltage wave crosses zero. Hence, it sends a 5V signal to microcontroller as step pulse input every time input signal crosses zero.



Fig.6 Transistor (BC-547)

#### C. CYCLOCONVERTER BOARD:

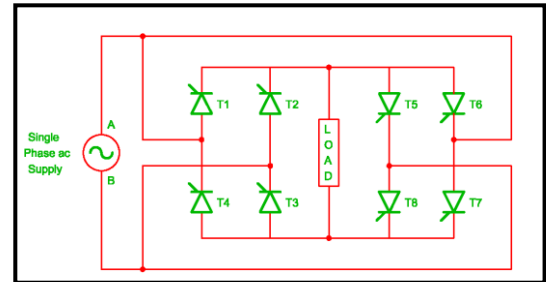

Fig.7 Cycloconverter circuit diagram

Figure 7 shows the Step-down bridge type cycloconverter. This circuit changes fixed frequency into some lower frequency's using power electronic devices. This board contains two essential parts

(i) **Opto isolators:** It is a combination of LED and photo transistor. This maintains isolation between power circuit and electronic circuit. These isolators get signals from the GPIO pins of the PIC microcontroller. When digital signal is obtained by the opto isolator, they provide high output signal to gate of the triacs allowing triggering.



Fig.8 Opto isolator

(ii) **TRIACS:** These are the power electronic devices which are used as switches in the cycloconverter to convert the input AC fixed frequency waveform into lesser frequency. The gate terminal of this triac is connected to isolator to get triggering pulse according to the program.



Fig.9 TRIAC

The cycloconverter consists of a positive and negative sequence bank. The positive circuit converts any signal into positive half cycle whereas the negative circuit converts any signal into negative half cycle. Together these two circuits can convert frequency into  $F/2, F/3$  and  $F/4$

#### D. PIC MICROCONTROLLER:

This is the main block of our project. This is the brain behind the total operation of the cycloconverter. This microcontroller gives signal to the opto isolators based on the code provided to it. It is also interface with the Wi-Fi module ESP8266 to receive commands from the android mobile. PIC16F877A is shown in figure 10.



Fig.10 PIC Microcontroller (PIC16F877A)

It uses 16 Bit instructions for its operation. A push button is connected to the RST pin of the microcontroller to restart the code every time operation is started. Two LEDs are connected in the circuit to indicate whether the board is operating or not. This simply takes the input from the user and processes it according to the code and sends output to the cycloconverter to operate.

**E. ESP8266:**

ESP8266 is a WIFI module which is pre-programmed and can be easily interfaced with the microcontroller used by us. In this project it is interfaced with PIC to control the speed of the motor in 4 different modes. It enables Wi-Fi options to the whole system and sends all the essential information to the cloud if required. This is the module with enables IOT in the circuit. Using this module, we can send signal to microcontroller from anywhere around the globe. *ESP8266 is shown in figure 11.*

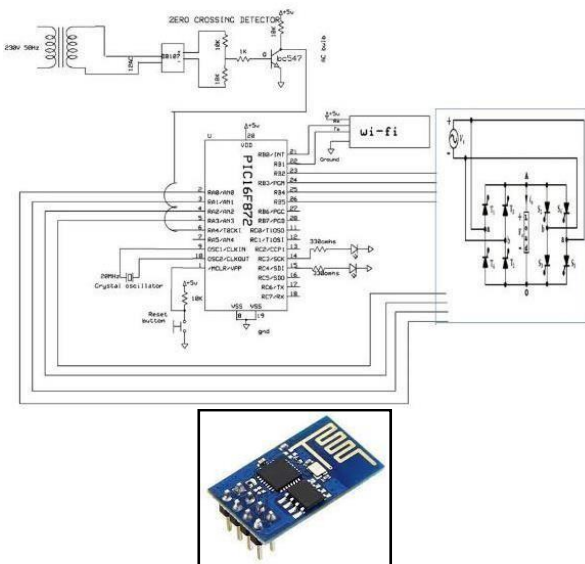

Fig.11 Wi-Fi Module (ESP8266)

**F. INDUCTION MOTOR:**

Single phase capacitor start induction motor is used in this project. There are two major parts in this motor. They are 1) Stator 2) rotor. Stator is the stationary part of the motor which is supplied with the single phase 230v AC. While rotor is the rotating part of the induction motor which induces some voltage into it using the principle of mutual induction from the stator. The induction motor used in the project is shown in figure 12.



Fig.12 Single Phase Induction Motor

Interaction of both stator and rotor flux causes motor to rotate. But, according to double field revolving theory, both stator flux and rotor flux cancel each other. Hence, single phase induction motor is not self-starting. To make induction motor self-starting, a starting capacitor is used in the auxiliary winding of the induction motor. This creates a phase difference between stator flux and rotor flux; hence the rotor tends to rotate at synchronous speed.

$$N_s = 120f/p$$

**V. SOFTWARE DESCRIPTION**

**A. BLYNK APPLICATION:**

Blynk is a new application which enables us to easily built interface with our hardware and enables us to make changes or control the equipment from a remote location. The application interface consists of a project profile where we can create various widgets and control switches. We link them with our virtual pins which are in turn associated with the digital pins of our microcontroller. Hence controlling those switches and widgets we can make changes in our hardware circuit.



Fig.13 Blynk logo



Fig.14 PIC C Compiler

**B. PIC C COMPILER:**

This is the IDE used for PIC microcontroller. This is similar to Arduino IDE for Arduino Uno. Program is written in this software using embedded C language and is dumped into our PIC microcontroller selecting the right port.

**VI. WORKING**

Fig.15 CIRCUIT DIAGRAM

The circuit diagram of the project is shown in figure 15. This project mainly works depending upon cyclo-converter operation. Cyclo-converter consists of Two single phase full bridge circuits. Our load (induction motor) is connected between these two bridges. These bridges consist of TRIACS which operates as switches to switch the AC frequency from 50Hz to some lower frequency. Gatepulses to this TRIACS are provided with the help of opto isolators. Here MOC3021 opto isolators are used for the triggering. These opto-isolators consists of IR LED one side and photo transistor or diode at the other end. Whenever a high signal is provided to the opto isolator it turns LED on. LED emits light onto the photo diode or transistor, Photo transistor is a device which operates or conducts only when there is light directed on it

I.e., whenever it is subjected to photons, electronic-hole pairs are generated near the depletion layer. This causes the diode or transistor to conduct. When this photo transistor conducts, TRIAC receives an active high gate signal. Hence the TRIAC starts conducting. In this way each TRIAC is provided with an opto isolator to control its switching.

Microcontroller GPIO pins are connected to the opto isolators to turn on and off the LEDs inside them. Opto isolators also provide isolation between the high voltage cyclo-converter circuit and low voltage micro controller circuit. Program is written and dumped in PIC microcontroller using PIC C compiler. The sequence of which TRIAC should be triggered when is written clearly in program to convert usual frequency (50Hz) into F/2, F/3, F/4 frequencies. These waveforms can be seen in figure 16.

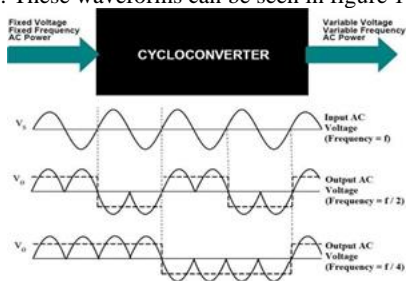

Fig.16 CYCLOCONVERTER WAVEFORMS

To convert the frequencies accurately zero crossing circuit will help the microcontroller to detect the point where the input frequency crosses zero and when to trigger the TRIACS. The TRIACS are usually triggered at every zero crossing of the input voltage frequency. Zero crossing detector circuit consists of a transformer, Bridge rectifier, voltage divider circuit and transistor. An active 5V will be given to the microcontroller pin every time input voltage crosses zero. Hence using this pin, program will be written.

Microcontroller is interfaced with the esp8266 Wi-Fi module to select the modes. There are 4 modes of operation for the cyclo-converter. Each mode will provide a different frequency to the induction motor to control the speed. Using blynk IOT, we can send the information from our mobile to the Wi-Fi module to switch the mode. A slider containing 5 different levels is used in the blynk Android interface to select the mode. Whenever the mode is changed in our mobile, information will be sent to Wi-Fi module. Which in turn provides information to the microcontroller about triggering. Finally, the induction motor speed is controlled easily and below rated speeds are obtained. The interface of blynk and the slider settings used in the project are shown in figures 17 & 18.



Fig.17 Slider settings

Fig.18 Blynk Android interface

## VII. RESULTS

S. No	Frequency (HERTZ)	Actual Frequency (HERTZ)	Period	Speed of the motor (RPM)
1	F	50	0.02	1440
2	F/2	25	0.04	720
3	F/3	16.7	0.06	480
4	F/4	12.5	0.08	360

Speed is controlled in 4 modes as shown in below table and these modes are controlled using our android mobile using Blynk application.

## VII. CONCLUSION

The demand for wireless control of electric equipment is increasing day by day. All industries and households are seeking for efficient and economical wire-less control over their appliances. Here we are controlling speed of an induction motor using WIFI module and Blynk application wirelessly. The objective of the project has been achieved which is to develop the hardware and software to control the speed of an induction motor (below rated speeds) using an Android application. A prototype has been successfully developed which satisfies all the proposed requirements of the project. From our study on this project, we conclude that, this project meets the desired requirements of industries and households about Speed control of an induction motor using Android application.

## REFERENCES

- [1] RICHA GAJBHIYE et al., "Speed Control of Induction Motor Using Single Phase Cycloconverter" Dept. of Electrical Engineering, 2017.
- [2] S. V. THIGALE et al., "Speed control of Induction motor using Cycloconverter with thyristor" Department of ELEC, 2017.
- [3] ABHIJIT MULE, "Android-based speed control of induction motor" Dept of Electrical Engineering, 2017.
- [4] B. SAI SINDURA et al., [4] "Speed Control of Induction Motor using Cycloconverter" Department of Electrical and Electronics Engineering, 2013.
- [5] P. R. Lole et al., "Speed Control of Induction Motor by Using Cyclo-converter" IOSR Journal of Electrical and Electronics Engineering, 2017.