



**ISSN: 2454-9940**



**INTERNATIONAL JOURNAL OF APPLIED  
SCIENCE ENGINEERING AND MANAGEMENT**

**E-Mail :**  
**editor.ijasem@gmail.com**  
**editor@ijasem.org**

**[www.ijasem.org](http://www.ijasem.org)**

# AI-BASED ACCIDENT DETECTION LOCATION TRACKING WITH SOS FEATURE

Pagala Ruthika<sup>1</sup>, Erukali Balakrishna<sup>2</sup>,  
Korva Sampath<sup>3</sup>, Dr. Pradeep Kumar<sup>4</sup>

<sup>1,2,3</sup> UG Student, Dept. of ECE, CMR Institute of Technology, Hyderabad

<sup>4</sup> Associate Professor, Dept. of ECE,  
CMR Institute of Technology, Hyderabad

## ABSTRACT

Road accidents rates are very high nowadays, especially two wheelers. Timely medical aid can help in saving lives. This system aims to alert the nearby medical center about the accident to provide immediate medical aid. The attached accelerometer in the vehicle senses the tilt of the vehicle and the a heartbeat sensor on the user's body senses the abnormality of the heartbeat to understand the seriousness of the accident. Thus the systems will make the decision and sends the information to the smartphone, connected to the accelerometer through gsm and gps modules . The Android application in the mobile phone will send text messages to the nearest medical center and friends. Application also shares the exact location of the accident and it can save time

## INTRODUCTION

Nowadays, the rate of accidents has increased rapidly. Due to employment, the usage of vehicles like cars, bikes have increased, because of this reason the accidents can happen due to over speed. People are going under risk because of their over speed, due to unavailability of advanced techniques, the rate of accidents can't be decreased. To reduce the accident rate in the country this paper introduces a solution. Automatic accident detection and alert systems are introduced. The main objective is to control the accidents by sending a message to the registered mobile, hospital and police station using wireless communications techniques. When an accident occurs in a city or any place, the message is sent to the registered mobile through GSM module in less time. Arduino is the heart of the system which helps in transferring the message to different devices in the system. Vibration sensor will be activated when the accident occurs and the information is transferred to the registered number through the GSM module. The GPS system will help in finding the location of the accident spot. The proposed system will check whether an accident has occurred

and notify nearest medical centers and registered mobile numbers about the place of accident using GSM and GPS modules. The location can be sent through a tracking system to cover the geographical coordinates over the area. The accident can be detected by a vibration sensor which is used as a major module in the system.

## LITERATURE SURVEY

- **DR.C.K.Gomathy , V.Geetha , S.Madhumitha , S.Sangeetha , R.Vishnupriya Article: A Secure With Efficient Data Transaction In Cloud Service, Published by International Journal of Advanced Research in Computer Engineering & Technology (IJARCET) Volume 5 Issue 4, March 2016, ISSN: 2278 – 1323.**

The software programs run from the systems. Data hiding is a secret information in an effective control with its original content and it's stored on servers accessed via the Internet. It denotes a major change in how its stored information and run applications. Instead of running programs and data on a systematic manner, everything is hosted in the cloud and servers access via the internet. An environment created in a user's machine from an online application stored in a cloud and run through a web browser. Security issues are becoming the major drawback of cloud. In previous work, security problems originate from Loss of control, Lack of trust, multi-tenancy. In this paper elaborates, the users are connected to the cloud through the internet and the primary and secondary keys are generated for data sharing, and the files can be encrypted by using merkle hash tree algorithm. If the user wants to download the files user have to ask permission from the data owner, only if the user is authenticated then the mutual key can be shared by the data owner in the form of steganography, so the user trust and seclusion is achieved. Cloud Computing has been anticipated as the next generation architecture of IT Enterprise. It's not the technology it is one of the computing model.

- **Dr.C.K.Gomathy, C K Hemalatha, Article: A Study On Employee Safety And Health Management International Research Journal Of Engineering And Technology (Irjet)- Volume: 08 Issue: 04 | Apr 2021**

This study is an outcome of the title called "A study on Employees Safety and Health". Employees Safety and Health look upon prevention of accidents basically as an

engineering problem to be tackled through proper designing of mechanical safety devices. In fact, accident prevention and safety are inter related and, therefore require a multidimensional approach. Its importance has increased because of large-scale industrialization in which human beings are subjected to mechanical, electrical and radiation hazards. In sample Total population is 669 from that 250 employees were selected using simple random sampling method and a well-structured questionnaire was framed in order to extract the required information from the respondents. Questionnaires were collected through personal interview. The various statistical tools like percentage method, chi square test and regression analysis were used in this study. The findings of the study reveal that major cause for the work place accident is unsafe handling of material. So the vestibule training method can be included in employee training program. Ergonomics method enables better employees safety and health. **Dr.C K Gomathy, Article: A Study on the Effect of Digital Literacy and information Management, IAETSD Journal For Advanced Research In Applied Sciences, Volume 7 Issue 3, P.No-51-57, ISSN NO: 2279-543X,Mar/2018**

Technological developments are currently playing a remarkable contribution in the life of modern society, and scientific knowledge becomes more impactful across numerous domains of society than any time ever. Digital literacy is underpinned by basic technical use of computers and the Internet. Digital literacy is the set of competencies required for full participation in a knowledge society. It includes knowledge, skills, and behaviors involving the effective use of digital devices such as Smartphone's, tablets, laptops and desktop PCs for purposes of communication, expression, collaboration and advocacy. The digital literacy initially focused on systematic digital skills and computers, the focus has moved from stand-alone to network devices including the World Wide Web and social media. Digital literacy is the marrying of the two terms digital and literacy. However, it is much more than a combination of the two terms.

**Dr.C K Gomathy, Article: An Effective Innovation Technology In Enhancing Teaching And Learning Of Knowledge Using Ict Methods, International Journal Of Contemporary Research In Computer Science And Technology (Ijcrct) E-Issn: 2395-5325 Volume3, Issue 4,P.No-10-13, April '2017**

With the rapid advancements of technology, online surveying is becoming a topic of great concern today and should be given much attention. Online surveying identifies a person and is permanently associated with the person and there will be a big blunder if the online surveying is compromised. So, it becomes the prime responsibility of an organization to store the online surveying features in a secured manner way. There are various approaches of online surveying tool and its template protection as well as the merits and demand. Surveying systems are recent advancements in the field of online tool and template protection which have strengthened public confidence and acceptance of overall the entire world. Today in the era of information technology, digital online world has become an integral part of our lives and thus are not alone selecting any product in the digital world. In this scenario, Online Surveys may be used as part of argument decision, or to importune opinions before making momentous changes or conclusions. **Dr.C K Gomathy, Article: Supply chain-Impact of importance and Technology in Software Release Management, International Journal of Scientific Research in Computer Science Engineering and Information Technology ( IJSRCSEIT ) Volume 3 | Issue 6 | ISSN : 2456-3307, P.No:1-4, July-2018.**

Today's market place is becoming gradually more dynamic and volatile as customers become more stylish and comfortable, always tend expect the right good quality developed software at the right time, at the affordable price and the right time and place. The software creation industry faces many kind pressures from the consumers to deliver the product at right time. The supply chain planning systems are companies to quick written manage the activities of the software release process. The creativity of planning and scheduling is the significant factor to attain the manufacturing task efficiently in the supply chain. Also public can find many issues regarding to software production planning and scheduling by both academic and business researchers. Software is a product delivering the computing potential embodied in computer hardware. It is also a vehicle to deliver the product as it acts as a basis for the control of the computer, the communication of information and the creation and control of other programs.

**C K Gomathy and V Geetha. Article: A Real Time Analysis of Service based using Mobile Phone Controlled Vehicle using DTMF for Accident Prevention. International**

**Journal of Computer Applications 138(2):11-13, March 2016. Published by Foundation of Computer Science (FCS), NY, USA,ISSN No: 0975-8887**

This paper explores direct phone-to-phone communication between the driver's phone & the owner's phone to support mobile sensing applications. Direct communication between driver's phone & owner's phone is an important in improving data collection efficiency and sharing participatory sensing information in an inexpensive manner. We design a practical and optimized communication mechanism for direct phone-to-phone data transfer to the driver's phone that strategically enables phone-to-phone communication. This paper makes use of the DTMF technology available on mobile phones to control the vehicle activities. We employ various sensors in the vehicle which sends us the information about the vehicle activities. In case of occurrence of any abnormalities in the functioning of vehicle, the sensors immediately detect these abnormalities & a message is sent to the vehicle owner.

## **EXISTING SYSTEM**

several existing systems and technologies address aspects of AI-based accident detection, location tracking, and SOS features. Companies and startups often develop solutions that integrate sensors, artificial intelligence algorithms, and communication technologies for enhanced vehicle safety. These systems typically leverage onboard accelerometers, gyroscopes, and GPS modules to monitor vehicle dynamics and location in real-time. Machine learning algorithms analyze this data to detect unusual patterns indicative of accidents. Some solutions include a dedicated SOS feature, allowing users to trigger emergency alerts manually. Communication is facilitated through cellular networks or dedicated IoT protocols, ensuring that relevant stakeholders receive timely notifications. These systems often come with user interfaces, such as mobile apps or web platforms, enabling users to monitor their vehicles and receive alerts. While specific implementations may vary, these technologies collectively contribute to improving road safety and emergency response capabilities. It's advisable to check for the latest developments and products in this field, as new solutions may have emerged since my last update.

## **Proposed system**



A proposed AI-based accident detection, location tracking, and SOS system aims to integrate cutting-edge technologies for enhanced vehicle safety and emergency response. The system will employ a combination of sensors, including accelerometers, gyroscopes, and GPS modules, installed in vehicles to continuously monitor real-time data. An advanced artificial intelligence algorithm will be developed to analyze this data, identifying patterns indicative of accidents with a high level of accuracy. The integration of GPS technology will enable precise location tracking, ensuring that emergency responders can quickly and accurately locate the vehicle in case of an incident. A dedicated SOS feature will be implemented, allowing users to manually trigger emergency alerts. Communication with a backend server and predefined contacts will be established through wireless technologies such as GSM or IoT protocols, facilitating real-time alerts. The system will include a user-friendly interface, accessible through mobile or web applications, enabling users to monitor their vehicles, track locations, and manage emergency settings. Privacy and security measures will be prioritized, and the system will comply with relevant regulations to ensure the protection of user data. This proposed solution aims to significantly enhance road safety and emergency response capabilities through the seamless integration of hardware, AI algorithms, and communication technologies

## BLOCK DIAGRAM

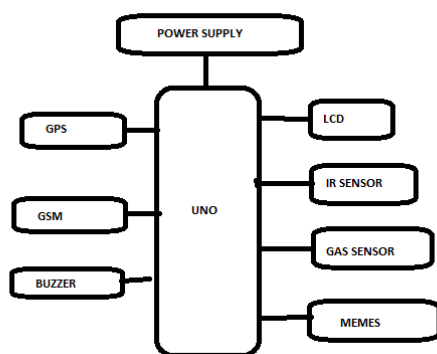

## HARDWARE COMPONENTS

### LCD (Liquid Cristal Display)

#### Introduction:

A liquid crystal display (LCD) is a thin, flat display device made up of any number of color or monochrome pixels arrayed in front of a light source or reflector. Each pixel consists of a column of liquid crystal molecules suspended between two transparent electrodes, and two polarizing filters, the axes of polarity of which are perpendicular to each other. Without the liquid crystals between them, light passing through one would be blocked by the other. The liquid crystal twists the polarization of light entering one filter to allow it to pass through the other.

A program must interact with the outside world using input and output devices that communicate directly with a human being. One of the most common devices attached to an controller is an LCD display. Some of the most common LCDs connected to the controllers are 16X1, 16x2 and 20x2 displays. This means 16 characters per line by 1 line 16 characters per line by 2 lines and 20 characters per line by 2 lines, respectively.

#### IR SENSOR

An infrared sensor is an electronic device, that emits in order to sense some aspects of the surroundings. An IR sensor can measure the heat of an object as well as detects the motion. These types of sensors measure only infrared radiation, rather than emitting it that is called a passive IR sensor. Usually, in the infrared spectrum, all the objects radiate some form of thermal radiation. These types of radiations are invisible to our eyes, that can be detected by an infrared sensor. The emitter is simply an IR LED (Light Emitting Diode) and the detector is simply an IR photodiode that is sensitive to IR light of the same wavelength as that emitted by the IR LED. When IR light falls on the photodiode, the resistances and the output voltages will change in proportion to the magnitude of the IR light received.



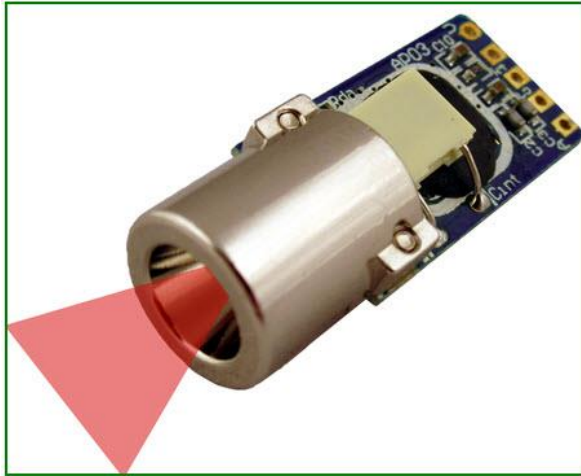

## LPG GAS SENSOR

**Description:** This is a simple-to-use [liquefied petroleum gas \(LPG\)](#) sensor, suitable for sensing LPG (composed of mostly propane and butane) concentrations in the air. The MQ-6 can detect gas concentrations anywhere from 200 to 10000ppm.



## GSM (Global System for Mobile communications)

### Introduction:

GSM (Global System for Mobile communications) is a cellular network, which means that mobile phones connect to it by searching for cells in the immediate vicinity. GSM networks operate in four different frequency ranges. Most GSM networks operate in the 900 MHz or 1800 MHz bands. Some countries in the Americas use the 850 MHz and 1900 MHz bands because the 900 and 1800 MHz frequency bands were already allocated.

## **BUZZERS**

In common parlance a Buzzer is a signaling device that is not a loudspeaker. It can be mechanical, electromechanical, or electronic (a piezo transducer). BeStar produces Buzzers in every available configuration for a wide variety of applications. A Piezo transducer can produce the sound for panel mount buzzers, household goods, medical devices and even very loud sirens. When a lower frequency is required an electromagnetic buzzer can fill the need. These are very common in automotive chimes and higher end clinical diagnostic devices. The BeStar buzzer range includes self drive units with their own drive circuitry (indicators), or external drive units, which allow the designer the flexibility to create their own sound patterns.

## **CONCLUSION**

The proposed programmed accident detection system can be a rescuer of life for the people who met with accidents. The proposed system is exceptionally easy to understand and even a non-specialized Person can use it without any problem. The system consists of equipment and programming segments. The equipment unit includes accident detection sensors that are constrained by an Arduino board and is fitted in the vehicle. Then again, the programming part is an Android application introduced in drivers Smartphones which is used to get the point by point map. In general, the benefits of this system are low cost, secure and simple to use. The system introduced in this work reduces the casualties due to accidents.

## **REFERENCES**

- [1] DR.C.K.Gomathy , V.Geetha , S.Madhumitha , S.Sangeetha , R.Vishnupriya Article: A Secure With Efficient Data Transaction In Cloud Service, Published by International Journal of Advanced Research in Computer Engineering & Technology (IJARCET) Volume 5 Issue 4, March 2016, ISSN: 2278 – 1323.
- [2] Dr.C.K.Gomathy,C K Hemalatha, Article: A Study On Employee Safety And Health Management International Research Journal Of Engineering And Technology (Irjet)- Volume: 08 Issue: 04 | Apr 2021

- [3] Dr.C K Gomathy, Article: A Study on the Effect of Digital Literacy and information Management, IAETSD Journal For Advanced Research In Applied Sciences, Volume 7 Issue 3, P.No-51-57, ISSN NO: 2279-543X,Mar/2018
- [4] Dr.C K Gomathy, Article: An Effective Innovation Technology In Enhancing Teaching And Learning Of Knowledge Using Ict Methods, International Journal Of Contemporary Research In Computer Science And Technology (Ijcrct) E-Issn: 2395-5325 Volume3, Issue 4,P.No-10-13, April '2017
- [5] Dr.C K Gomathy, Article: Supply chain-Impact of importance and Technology in Software Release Management, International Journal of Scientific Research in Computer Science Engineering and Information Technology ( IJSCSEIT ) Volume 3 | Issue 6 | ISSN : 2456-3307, P.No:1-4, July-2018.
- [6] C K Gomathy and V Geetha. Article: A Real Time Analysis of Service based using Mobile Phone Controlled Vehicle using DTMF for Accident Prevention. International Journal of Computer Applications 138(2):11-13, March 2016. Published by Foundation of Computer Science (FCS), NY, USA,ISSN No: 0975-8887
- [7] C K Gomathy and V Geetha. Article: Evaluation on Ethernet based Passive Optical Network Service Enhancement through Splitting of Architecture. International Journal of Computer Applications 138(2):14-17, March 2016. Published by Foundation of Computer Science (FCS), NY, USA, ISSN No: 0975-8887
- [8] C.K.Gomathy and Dr.S.Rajalakshmi.(2014), "A Software Design Pattern for Bank Service Oriented Architecture", International Journal of Advanced Research in Computer Engineering and Technology(IJARCET), Volume 3,Issue IV, April 2014,P.No:1302- 1306, ,ISSN:2278-1323.
- [9] C. K. Gomathy and S. Rajalakshmi, "A software quality metric performance of professional management in service oriented architecture," Second International Conference on Current Trends in Engineering and Technology - ICCTET 2014, 2014, pp. 41-47, doi: 10.1109/ICCTET.2014.6966260.
- [10] Dr.C K Gomathy, V Geetha ,T N V Siddartha, M Sandeep , B Srinivasa Srujay Article: Web Service Composition In A Digitalized Health Care Environment For Effective Communications, Published by International Journal of Advanced Research in Computer Engineering & Technology (IJARCET) Volume 5 Issue 4, April 2016, ISSN: 2278 – 1323.

- [12] Reddy, K. Niranjana, and P. V. Y. Jayasree. "Design of a Dual Doping Less Double Gate Tfet and Its Material Optimization Analysis on a 6t Sram Cells."
- [13] Reddy, K. Niranjana, and P. V. Y. Jayasree. "Low power process, voltage, and temperature (PVT) variations aware improved tunnel FET on 6T SRAM cells." *Sustainable Computing: Informatics and Systems* 21 (2019): 143-153.
- [14] Reddy, K. Niranjana, and P. V. Y. Jayasree. "Survey on improvement of PVT aware variations in tunnel FET on SRAM cells." In *2017 International Conference on Current Trends in Computer, Electrical, Electronics and Communication (CTCEEC)*, pp. 703-705. IEEE, 2017
- [15] Karne, R. K. ., & Sreeja, T. K. . (2023). PMLC- Predictions of Mobility and Transmission in a Lane-Based Cluster VANET Validated on Machine Learning. *International Journal on Recent and Innovation Trends in Computing and Communication*, 11(5s), 477–483. <https://doi.org/10.17762/ijritcc.v11i5s.7109>
- [16] Radha Krishna Karne and Dr. T. K. Sreeja (2022), A Novel Approach for Dynamic Stable Clustering in VANET Using Deep Learning (LSTM) Model. *IJEER* 10(4), 1092-1098. DOI: 10.37391/IJEER.100454.
- [17] Reddy, Kallem Niranjana, and Pappu Venkata Yasoda Jayasree. "Low Power Strain and Dimension Aware SRAM Cell Design Using a New Tunnel FET and Domino Independent Logic." *International Journal of Intelligent Engineering & Systems* 11, no. 4 (2018).