



ISSN: 2454-9940



**INTERNATIONAL JOURNAL OF APPLIED
SCIENCE ENGINEERING AND MANAGEMENT**

E-Mail :
editor.ijasem@gmail.com
editor@ijasem.org

www.ijasem.org

Smart Agriculture Using Internet of Things with Raspberry Pi

Gantenapalli Swathi¹, Yerukala Manisha²,
Bolumala Sravanya³, Dr. B.V.Krishnaveni⁴

^{1,2,3} UG Student, Dept. of ECE, CMR Institute of Technology, Hyderabad

⁴ Associate Professor, Dept. of ECE,
CMR Institute of Technology, Hyderabad

Introduction

The term used for networking of objects, equipment, vehicles, and other electronics device into the network for information exchange purpose is called Internet of Things (IoT). Nowadays, IoT is widely used for connecting device and collecting data information. Therefore, the use of IoT is very relevant for agriculture. The project is about smart agriculture system that is implemented with IoT. The system is combined with irrigation system in order to cope with the unpredictable weather in Malaysia. Raspberry Pi 4 Model B is used as the microcontroller of this system. DHT22 and soil moisture sensor is used to detect the temperature and humidity in surrounding and moisture level of the soil respectively where the output will be displayed on smartphone and computer. So, Smart Agriculture Systems using Internet of Things with Raspberry Pi brings a

tremendous impact on the farmer's working method. Plus, it will also bring a positive effect on the crop production in Malaysia. Where about 24.44% water savings rate in a year can be achieved when using IoT-based irrigation systems compared to traditional irrigation systems. This would save the expenditure for hiring workers and avoid water wastage in daily needs.

Introduction

Initially Malaysia was a country based on agriculture and fisheries, it was a service that contributed about 55 per cent of Malaysia's gross domestic product (GDP). For decades, due to the growth of the local industry and the contribution services sector, the Malaysian agriculture sector has been declining. Almost 30 percent of GDP was contributed by agriculture in 1970 but this percentage has dropped sharply to 8.2 percent in 2017 [1]. The percentage drop in GDP value is due to farmers or gardeners

are still using traditional methods which affect the production rate of crops and fruits due to low soil fertility, fertilizer abuse, water waste and climate change or diseases [2]. The most challenging threats of agriculture in Malaysia is climate change. Plus, the most challenging effects include unpredicted weather like variations and fluctuation of summer and monsoon seasons, high temperature ($>26^{\circ}\text{C}$) and shortage of rainfall [3]. Therefore, the local agriculture sector should be given some improvements, especially the source of food crops. To reach that various technologies and innovations have been introduced to the Malaysian agricultural sector, such as agriculture which has the concept of industrial revolution 4.0 or smart agriculture to keep the agricultural sector in Malaysia in decline. In order to realize the industry of revolution 4.0 there are several things to keep in mind as one of them is the internet of things (IoT). IoT can be described as a network of devices that enables communication between machine and device through internet connection. IoT can also be described as a connection that does not require physical contact either from device to machine or from person to machine and has many capabilities to transmit or receive

data over the internet due to its interrelated with any peoples, animals, devices machines, or objects [4]. Refer to the [5], obtaining communication technology is the key in order to successfully develop IoT system. Short-range and long-range communication standard is the part of communication standard. Several examples of the short-range standards are near-field communications enabled device, Bluetooth, ZigBee, passive and active and active radio frequency identification (RFID) system and LoRa, Sigfox, NB-IoT and Wi-Fi are the example for the long-range standard. Several semi-automated and automated irrigation control system have been proposed to overcome the water wastage and growth crops production. Timers, controllers and switches have been widely used as irrigation control systems to supply water to crops at specific intervals regardless of the soil moisture level. According to D. Amu and Dr. A. Amuthan [6], the use of Arduino microcontrollers, Global System for Mobile Communication (GSM) technology and soil moisture sensors can help improve irrigation systems and save water usage and increase productivity. In placing more emphasis, Rabiun Aminu [7] and Sudarshan K G [8] claimed that combination of soil moisture

sensor and GSM module enables real time monitoring of crops remotely and all statuses can be received by the farmer via short message (SMS). Accordingly, the problem of distance and range can be solved besides ensuring that the irrigation system operates based on soil moisture content and it can reduce water consumption. But the mobile communication technology has transmission range that covers only the entire cellular area [9].

Literature survey

I. Mat, M. R. Mohd Kassim, A. N. Harun, and I. M. Yusoff, "Smart agriculture using internet of things," 2018 IEEE Conf. Open Syst. ICOS 2018, pp. 54–59, 2019.

The term used for networking of objects, equipment, vehicles, and other electronics device into the network for information exchange purpose is called Internet of Things (IoT). Nowadays, IoT is widely used for connecting device and collecting data information. Therefore, the use of IoT is very relevant for agriculture. The project is about smart agriculture system that is implemented with IoT. The system is combined with irrigation system in order to cope with the unpredictable weather in Malaysia. Raspberry Pi 4 Model B is used as the microcontroller of this system. DHT22 and soil moisture sensor is used to detect the

temperature and humidity in surrounding and moisture level of the soil respectively where the output will be displayed on smartphone and computer. So, Smart Agriculture Systems using Internet of Things with Raspberry Pi brings a tremendous impact on the farmer's working method. Plus, it will also bring a positive effect on the crop production in Malaysia.

C. Siwar, M. M. Alam, M. W. Murad, and A. Q. Al-Amin, "A Review of the Linkages between Climate Change , Agricultural Sustainability and Poverty in Malaysia," Int. Rev. Bus. Res. Pap., vol. 5, no. 6, pp. 309–321, 2009.

This paper empirically explored climate change, its related impact on rice agriculture and proper policyrelated strategies and mechanism. Our current assessment provided the expected climate change impact based on observational records of inter-annual variability in precipitation and warming climatic factors up to the year 2080. In this study, an analysis of the impact due to climate change and vulnerabilities is performed using Global Circulation Models together with Crop Modelling to represent a range of plausible climate scenarios. The approach used follows a bottom-up strategy, focusing on the vulnerability of Malaysian rice agriculture under various climatic conditions and gives a wide range of potential climate outcomes for rice agriculture in Malaysia. Our projections generated likely future changes and

uncertainties on rice production, the potential path for planning strategies and, finally, prioritizing requirements and influences in investment decisions to reduce vulnerabilities.

F. Kamaruddin, N. Noordini, N. Abd, and N. A. Murad, "IoT-based intelligent irrigation management and monitoring system using arduino," Telkomnika, vol. 17, no. 5, pp. 2378–2388, 2019.

Monitoring irrigation is still the problem of agriculture in Indonesia. During the dry season, the farming fields drought while in the rainy season, floods happened. Since the farm-fields located far from the urban area, it requires an automatic tool for monitoring the availability of water that can help the farmer to monitor the farm-field. Wireless sensor network is an appropriate technology used to overcome problems related to the monitoring system. This research is using a water level sensor, pump, Arduino Nano, and XBee Pro S2C in each monitoring node. The system designed within two modules, an automation irrigation module and a monitoring module, which is connected with the communication configuration of master-slaves between Xbee Pro S2C at each node. The system examined several scenarios in order to test the performance. Based on the testing result, all the performance parameters can be adequately delivered to the user and appropriated with the real condition in the farm field. The delay between nodes only takes 5-10 seconds.

Agriculture is one of the sectors that has become the Indonesian government's program to produce an optimal agricultural product.

O. Elijah, T. A. Rahman, I. Orikumhi, C. Y. Leow, and M. N. Hindia, "An Overview of Internet of Things (IoT) and Data Analytics in Agriculture: Benefits and Challenges," IEEE Internet Things J., vol. 5, no. 5, pp. 3758–3773, 2018.

The surge in global population is compelling a shift toward smart agriculture practices. This coupled with the diminishing natural resources, limited availability of arable land, increase in unpredictable weather conditions makes food security a major concern for most countries. As a result, the use of Internet of Things (IoT) and data analytics (DA) are employed to enhance the operational efficiency and productivity in the agriculture sector. There is a paradigm shift from use of wireless sensor network (WSN) as a major driver of smart agriculture to the use of IoT and DA. The IoT integrates several existing technologies, such as WSN, radio frequency identification, cloud computing, middleware systems, and end-user applications. In this paper, several benefits and challenges of IoT have been identified. We present the IoT ecosystem and how the combination of IoT and DA is enabling smart agriculture. Furthermore, we provide future trends and opportunities which are categorized into

technological innovations, application scenarios, business, and marketability.

Existing system

The integration of Smart Agriculture using the Internet of Things (IoT) with Raspberry Pi presents a transformative approach to modern farming practices. In the existing system, IoT devices, including sensors and actuators, are deployed in agricultural fields and connected to Raspberry Pi microcontrollers. These devices facilitate the collection of real-time data on various environmental parameters such as soil moisture, temperature, humidity, and crop health. The Raspberry Pi serves as a central processing unit, collecting, processing, and transmitting the data to a cloud-based platform or a local server.

The IoT-enabled Smart Agriculture system provides farmers with valuable insights into the conditions of their fields, allowing for data-driven decision-making. For instance, soil moisture sensors help optimize irrigation practices by indicating when and how much water is needed, minimizing water wastage and promoting water conservation. Temperature and humidity sensors contribute to monitoring environmental conditions, helping farmers adjust cultivation strategies and protect crops from adverse weather effects.

Raspberry Pi's role in this system extends beyond data collection to actuation and control. Through connected actuators, farmers can remotely control irrigation systems, greenhouse conditions, or even

deploy pest control measures based on the data received. This level of automation enhances operational efficiency, reduces manual intervention, and enables farmers to manage larger areas of cultivation more effectively.

The collected data is often sent to a cloud-based platform for further analysis and visualization. Farmers can access this information through user-friendly interfaces, typically web or mobile applications, allowing them to monitor their fields in real time. Additionally, historical data analysis can aid in identifying trends, optimizing crop cycles, and improving overall farm productivity.

In conclusion, the integration of IoT with Raspberry Pi in Smart Agriculture represents a significant advancement in precision farming. This technology not only empowers farmers with real-time insights but also promotes sustainable and resource-efficient agricultural practices, ultimately contributing to increased crop yields and the overall modernization of the agricultural sector.

Proposed system

The proposed system for smart agriculture using the Internet of Things (IoT) with Raspberry Pi represents an innovative approach to modernizing and optimizing agricultural practices. The system leverages IoT technology, where a network of sensors and devices is interconnected to collect, transmit, and analyze data in real-time. In this context, Raspberry Pi serves as a cost-

effective and versatile platform for deploying IoT applications in the agricultural domain.

The core components of the system include various sensors such as soil moisture sensors, temperature and humidity sensors, and cameras, all connected to a Raspberry Pi device. These sensors are strategically placed in the agricultural field to monitor key environmental parameters. The collected data is then transmitted to a centralized database or cloud platform, enabling farmers to access information remotely through a user-friendly interface.

One of the key features of this proposed system is its ability to provide precise and timely information for decision-making. For instance, soil moisture levels can be monitored to optimize irrigation schedules, ensuring that crops receive the right amount of water. Temperature and humidity data contribute to effective climate control in greenhouses, while cameras can be used for visual monitoring of crop health and growth.

The integration of IoT technology also enables predictive analytics. By analyzing historical data and trends, the system can generate insights that help farmers anticipate crop diseases, pest infestations, or adverse weather conditions. This proactive approach allows for timely interventions, reducing the risk of crop loss and improving overall yield.

Additionally, the use of Raspberry Pi in this system ensures scalability and ease of deployment. Farmers can gradually expand

the network of sensors based on their specific needs, and the open-source nature of Raspberry Pi allows for customization and integration with other smart agriculture technologies.

In conclusion, the proposed smart agriculture system using IoT with Raspberry Pi offers a comprehensive solution to enhance productivity and sustainability in farming. By providing real-time data, predictive insights, and a scalable platform, this system empowers farmers to make informed decisions and adopt precision agriculture practices for improved efficiency and yield.

Block diagram

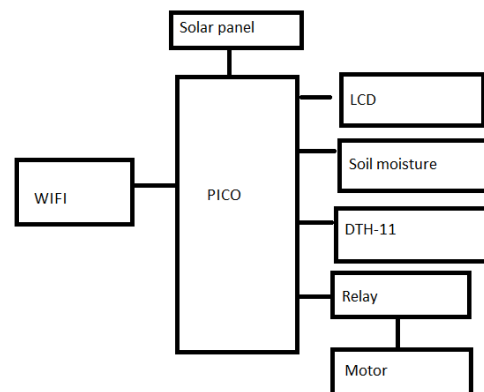

SOIL MOISTURE METER, SOIL HUMIDITY SENSOR, WATER SENSOR, SOIL HYGROMETER FOR ARDUNIO



This is Soil Moisture Meter, Soil Humidity Sensor, Water Sensor, Soil Hygrometer for **Arduinio**. With this module, you can tell when your plants need watering by how moist the soil is in your pot, garden, or yard. The two probes on the sensor act as variable resistors. Use it in a home automated watering system, hook it up to IoT, or just use it to find out when your plant needs a little love. Installing this sensor and its PCB will have you on your way to growing a green thumb!

The soil moisture sensor consists of two probes which are used to measure the volumetric content of water. The two probes allow the current to pass through the soil and then it gets the resistance value to measure the moisture value.

When there is more water, the soil will conduct more electricity which means that there will be less resistance. Therefore, the moisture level will be higher. Dry soil conducts electricity poorly, so when there will be less water, then the soil will conduct less electricity which means that there will be more resistance. Therefore, the moisture level will be lower.

DHT TEMPERATURE & HUMIDITY SENSORS.

These sensors are very basic and slow, but are great for hobbyists who want to do some basic data logging. The DHT sensors are made of two parts, a capacitive humidity sensor and a thermistor. There is also a very basic chip inside that does some analog to digital conversion and spits out a digital signal with the temperature and humidity. The digital signal is fairly easy to read using any microcontroller.

Humidity is the measure of water vapour present in the air. The level of humidity in air affects various physical, chemical and biological processes. In industrial applications, humidity can affect the business cost of the products, health and safety of the employees. So,

in semiconductor industries and control system industries measurement of humidity is very important. Humidity measurement determines the amount of moisture present in the gas that can be a mixture of water vapour, nitrogen, argon or pure gas etc... Humidity sensors are of two types based on their measurement units. They are a relative humidity sensor and Absolute humidity sensor. DHT11 is a digital temperature and humidity sensor.

RELAY MODULE

Relay modules are simply circuit boards that house one or more relays. They come in a variety of shapes and sizes, but are most commonly rectangular with 2, 4, or 8 relays mounted on them, sometimes even up to a 16 relays.

Relay modules contain other components than the relay unit. These include [indicator LEDs](#), [protection diodes](#), transistors, resistors, and other parts. But what is the module relay, which makes the bulk of the device? You may ask. Here are facts to note about it:

- A relay is an electrical switch that can be used to control devices and systems that use higher voltages. In

the case of module relay, the mechanism is typically an [electromagnet](#).

- The relay module input voltage is usually DC. However, the electrical load that a relay will control can be either AC or DC, but essentially within the limit levels that the relay is designed for.
- A relay module is available in an array of input voltage ratings: It can be a 3.2V or 5V relay module for low power switching, or it can be a 12 or 24V relay module for heavy-duty systems.
- The relay module information is normally printed on the surface of the device for ready reference. This includes the input voltage rating, switch voltage, and current limit.

Conclusion

This research has successfully implemented water irrigation system which meets the target of water-saving purposes as it is equipped with self-intelligent capability. The findings revealed that the soil moisture state is under strong control because it is proven that the planned irrigation scheme

did not conduct the watering process when the soil is above the level of excessive watering purposes or on rainy day. The network thus helps to conserve water use and to avoid overwater or contamination of the plants. For future improvement, pH sensor, light detection, soil condition checker, and crop observation could be added to make the system more efficient by using image processing. Consequently, authorities should start to think that more research on agriculture-related projects is worthwhile

References

- [1] I. Mat, M. R. Mohd Kassim, A. N. Harun, and I. M. Yusoff, "Smart agriculture using internet of things," 2018 IEEE Conf. Open Syst. ICOS 2018, pp. 54–59, 2019.
- [2] K. A. Patil and N. R. Kale, "A model for smart agriculture using IOT," *Int. J. Innov. Technol. Explor. Eng.*, vol. 8, no. 6, pp. 1656–1659, 2019.
- [3] C. Siwar, M. M. Alam, M. W. Murad, and A. Q. Al-Amin, "A Review of the Linkages between Climate Change , Agricultural Sustainability and Poverty in Malaysia," *Int. Rev. Bus. Res. Pap.*, vol. 5, no. 6, pp. 309–321, 2009.
- [4] F. Kamaruddin, N. Noordini, N. Abd, and N. A. Murad, "IoT-based intelligent irrigation management and monitoring system using arduino," *Telkomnika*, vol. 17, no. 5, pp. 2378–2388, 2019.
- [5] O. Elijah, T. A. Rahman, I. Orikumhi, C. Y. Leow, and M. N. Hindia, "An Overview of Internet of Things (IoT) and Data Analytics in Agriculture: Benefits and Challenges," *IEEE Internet Things J.*, vol. 5, no. 5, pp. 3758–3773, 2018.
- [6] D. Amu, A. Amuthan, S. S. Gayathri, and A. Jayalakshmi, "Automated Irrigation using Arduino sensor based on IOT," 2019 *Int. Conf. Comput. Commun. Informatics*, pp. 1–6, 2019.
- [7] R. Aminu and A. Sugathakumari, Deepthi Raveendrababu, "Dynamic soil moisture control system for irrigation using GSM," *Sustain. Res. Innov. Conf.*, pp. 122–129, 2018.
- [8] P. Lashitha Vishnu Priya, N. Sai Harshith, and D. N.V.K.Ramesh, "Smart agriculture monitoring system using IoT," *Int. J. Eng. Technol.*, vol. 7, no. 2.7, p. 308, 2018.
- [9] P. P. Ray, "Internet of things for smart agriculture: Technologies, practices and future direction," *J. Ambient Intell. Smart Environ.*, vol. 9, no. 4, pp. 395–420, 2017.

- [10] F. S. Dinniyah, W. Wahab, and M. Alif, "Simulation of Buck-Boost Converter for Solar Panels using PID Controller," *Energy Procedia*, vol. 115, pp. 102–113, 2017..
- [12] Reddy, K. Niranjana, and P. V. Y. Jayasree. "Design of a Dual Doping Less Double Gate Tfet and Its Material Optimization Analysis on a 6t Sram Cells."
- [13] Reddy, K. Niranjana, and P. V. Y. Jayasree. "Low power process, voltage, and temperature (PVT) variations aware improved tunnel FET on 6T SRAM cells." *Sustainable Computing: Informatics and Systems* 21 (2019): 143-153.
- [14] Reddy, K. Niranjana, and P. V. Y. Jayasree. "Survey on improvement of PVT aware variations in tunnel FET on SRAM cells." In 2017 International Conference on Current Trends in Computer, Electrical, Electronics and Communication (CTCEEC), pp. 703-705. IEEE, 2017
- [15] Karne, R. K. ., & Sreeja, T. K. . (2023). PMLC- Predictions of Mobility and Transmission in a Lane-Based Cluster VANET Validated on Machine Learning. *International Journal on Recent and Innovation Trends in Computing and Communication*, 11(5s), 477–483. <https://doi.org/10.17762/ijritcc.v11i5s.7109>
- [16] Radha Krishna Karne and Dr. T. K. Sreeja (2022), A Novel Approach for Dynamic Stable Clustering in VANET Using Deep Learning (LSTM) Model. *IJEER* 10(4), 1092-1098. DOI: 10.37391/IJEER.100454.
- [17] Reddy, Kallem Niranjana, and Pappu Venkata Yasoda Jayasree. "Low Power Strain and Dimension Aware SRAM Cell Design Using a New Tunnel FET and Domino Independent Logic." *International Journal of Intelligent Engineering & Systems* 11, no. 4 (2018).