



ISSN: 2454-9940



**INTERNATIONAL JOURNAL OF APPLIED
SCIENCE ENGINEERING AND MANAGEMENT**

**E-Mail :
editor.ijasem@gmail.com
editor@ijasem.org**

www.ijasem.org

SMART FLOOD PREDITION AND ALERT SYSTEM WITH IOT INTEGRATION

¹ Nagaraju Paidimalla, ² N.Suma Vinaya Sri

¹ASSOCIATE PROFESSOR, KAKINADA INTERNATIONAL SCHOOL OF TECHNOLOGY AND SCIENCE,
ANDHRAPRADESH, INDIA, 533294

²M.TECH ES, DEPT OF E.C.E, KAKINADA INTERNATIONAL SCHOOL OF TECHNOLOGY AND SCIENCE,
ANDHRAPRADESH, INDIA, 533294

ABSTRACT:

Natural and unexpected natural disasters can cause economic loss, disruption, and insecurity for the country. In comparison to other natural hazards, floods cause more economic harm, as well as more deaths and property damage. The major things we can do to prevent, protect from, minimize, and forecast these types of disasters. This paper primarily focuses on forecasting, which is required to provide victims in a location with a high risk of flooding with an early warning.

The victim may be able to obtain accurate flood information in real-time by integrating Internet of Things technology into the system. This creates a real-time flood monitoring and early warning system using wireless sensor nodes at a high-risk location of flooding.

The NodeMCU based technology used in this system is connected using the Blynk application.

When a flood or heavy rain happens, the wireless sensor node can assist the victims by monitoring the water levels and rain intensity and issuing an early warning. The sensor node, which is located at the designated flood region, is made up of rain and ultrasonic sensors and is controlled by NodeMCU, the system's microcontroller. As the floodreacheda particular threshold of danger, the buzzer and LED started to activate and inform the victim. With a wireless connection, the Blynk application receives data collected by the sensors. By seeing the UI and getting a push notification from the Blynk application on aniOS or Android smartphone, the victim will learn the status of the flood and rain.

INTRODUCTION

A flood monitoring system has been developed to observe the status of flood and warn people who are frequently affected by floods. The system includes a sensor node which detects the water level and rain intensity using an Ultrasonic Distance Sensor (HCSR04) and rain sensor, respectively. When the water level and rain intensity reach a certain level of hazards, the device will generate an alarm system with two different colors of LED's indicating two levels of detection for flood level. People who are in the area that is being monitored will be notified with an incoming flood alert

EXISTING SYSTEM:

On Floods so far, several literature studies have been conducted in order to gain the understanding and the knowledge to implement an advance flood monitoring system. L. Siew Khaun et al were able to invent a system that could detect the water depth when it is over the standard level as specified by the sensor. This paper was then placed where a flood always occurs. This paper had the ability to use the flashlight as a warning and also inform the control room. In this paper Radiofrequency transmitter and receiver were used for information communication.

the water level monitoring was done using the android smart and ultrasonic sensors. In this paper, the information about the flooding would be available on android applications. This system had an error rate of 1.121%.

PROPOSED SYSTEM:

The Proposed system consists of Rain Sensor, Ultrasonic Sensor, Power Source, NodeMCU ESP8266, Buzzer and LEDs and finally Blynk App. This Wireless Sensor Node is Kept in desired location Like dam, Bridge. etc. and Blynk App is downloaded by victims near the flooding area. The Schematic Diagram of the proposed flood forecasting and Monitoring System is shown in fig3.1.

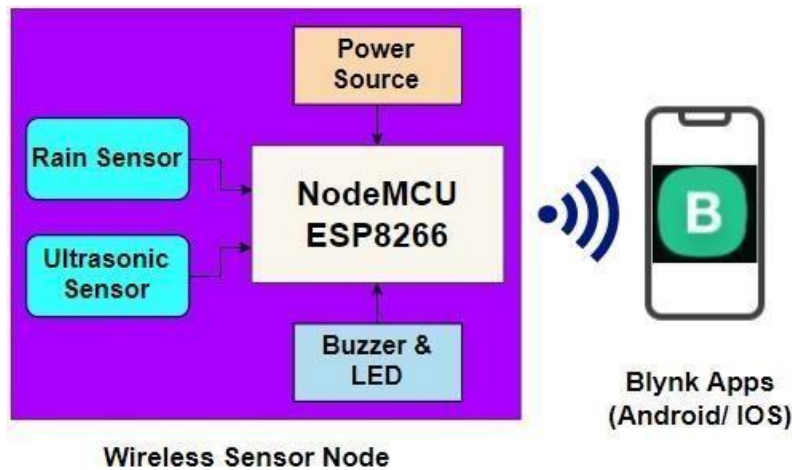

Fig – 3.1 Schematic Diagram of the Proposed Flood Warning and Monitoring System

The proposed system will help in predicting the flood with the factors of water level change and rain fall intensity. The wireless sensor node consists of rain sensor which is used to measure the rain intensity. When there is no rain fall the intensity is “0” and if rainfall starts the intensity starts increasing and the speed the rain fall the intensity increases. The intensity is sent to NodeMCU which checks the value which is defined in code. the checked value with threshold. if more than threshold then there will be a alert to victims as flood is predicted.

Even when the water level changes based on given threshold values it checks and send alerts. The warning is in three stages Safe level, Warning Level, Critical Level. The alert can of 2 types one way is send notification to victims and other one way is buzzer sound.

For Sending Notifications The victims should have Blynk App in Mobile phone. The LEDs are also displayed according to the water level, green, yellow, red. The connections of devices are done using jumper wires. The code is Written is Arduino ide and dumped into nodeMCU. The sending of information from NodeMCU to Blynk app is with the help of Esp 8266. The ESP8266 is Wi-Fi module which is in built in NodeMCU

CIRCUIT DIAGRAM

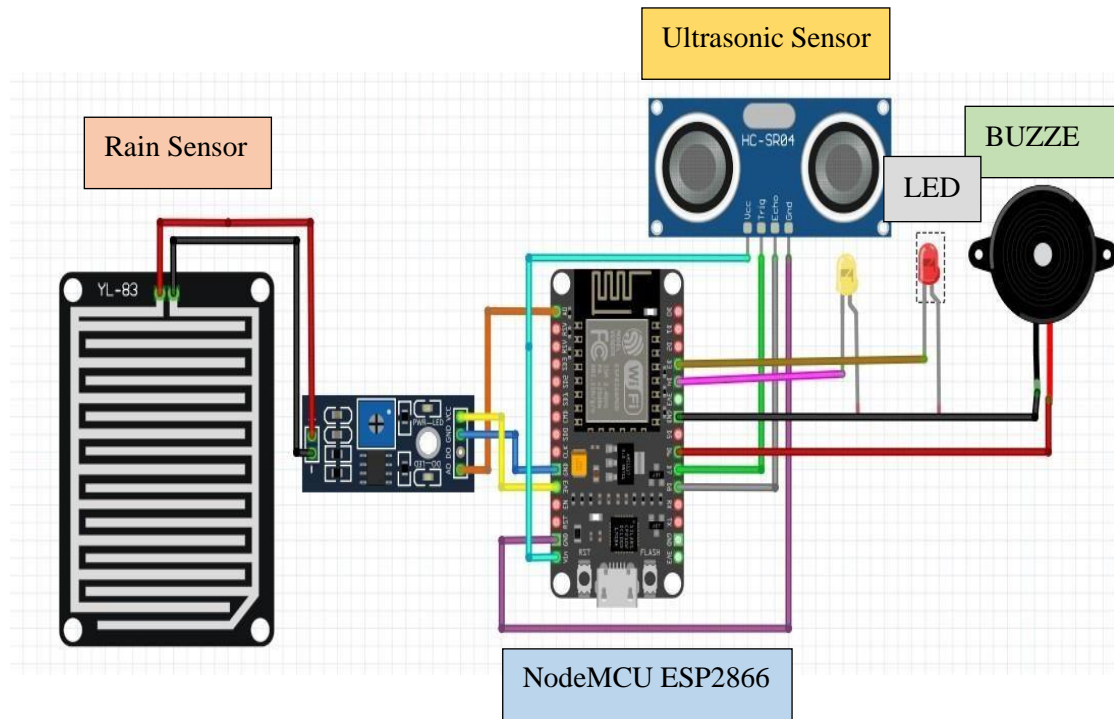

Fig - 3.2 Circuit Diagram of Proposed System

A P-N junction can convert absorbed light energy into a proportional electric current. The same process is reversed here (i.e., the P-N junction emits light when electrical energy is applied to it). This phenomenon is generally called electroluminescence, which can be defined as the emission of light from a semi-conductor under the influence of an electric field. The charge carriers recombine in a forward-biased P-N junction as the electrons cross from the N-region and recombine with the holes existing in the P-region. Free electrons are in the conduction band of energy levels, while holes are in the valence energy band. Thus, the energy level of the holes will be lesser than the energy levels of the electrons. Some portion of the energy must be dissipated in order to recombine the electrons and the holes. This energy is emitted in the form of heat and light. The electrons dissipate energy in the form of heat for silicon and germanium diodes but in gallium arsenide phosphide

(GaAsP) and gallium phosphide (GaP) semiconductors, the electrons dissipate energy by emitting photons. If the semiconductor is translucent, the junction becomes the source of light as it is emitted, thus becoming a light-emitting diode, but when the junction is reverse biased no light will be produced by the LED and, on the contrary, the device may also be damaged.

RESULTS AND DISCUSSIONS:

The prototype works accordingly, an experiment was conducted to test the measurement of water detected by wireless sensor node. Buzzer and LED started to trigger when the water level reached 40 until it reaches critical level (62) in the gauge, a notification sent to victim through Blynk and email. Rain sensor detects the rain intensity and sends an alert when rain heavily started.

There are two interface tabs mode displays on the screen of the smartphone. It displayed the water level and rain intensity to alert victims in a high prone area of flood. The distance of the water is also displayed on the widgets which used gauge as the indicator and also the show the value in labeled value widget. This history graph can be used to track the flood level in real time condition. There will be two stages which are level 1, level 2 to give alarm to the people. The data sensed by the sensor was displayed on the Blynk's interface reflecting the level indicator as well as the distance. Once the data being received, LED started to trigger when level 1 of flood level detected. Then, at level 2 white LED turn on, as well as the buzzer. Once the water level reached 40, 62 in gauge, the system will send the alert warning and critical notification to the user via email and Blynk push notification.

Water level	Level Indicator	Alert
0 - 8 cm	1	safe
9 - 12 cm	2	Warning
13 and more cm	3	Critical
Rain Intensity	Level Indicator	Alert
6.0 mm/hr	1	"Rain is falling very heavily"

FIG-6.1: Water Level and Rain intensity level indicators

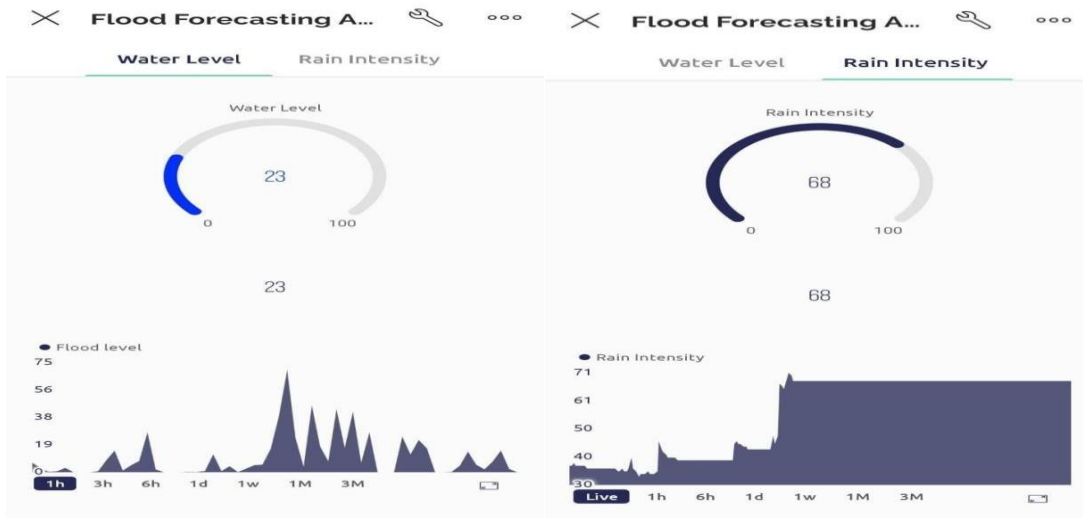

FIG-6.2: Interface of Water Level and Rain Intensity

The level of rain intensity which is in Blue colour shows that the rain just started to fall. This indicates that the people who live nearby should alert as they know their place will get a very disastrous disaster if the rain started heavily. "Rain Warning!!" notification is sent to the user fore alerting purposes.

The victims who frequently experience flooding in their neighborhood must take the rain intensity into consideration because it has reached a certain point. The reason for this is because as the rain began to pour steadily, there was a great likelihood that a flood might happen at that location at any time. "Rain is falling heavily!" is the message that the

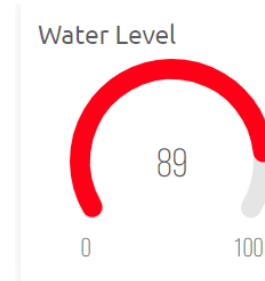
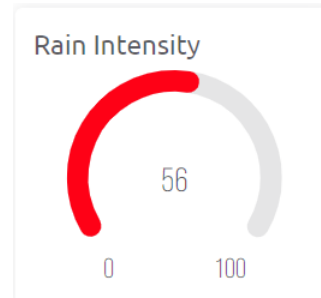
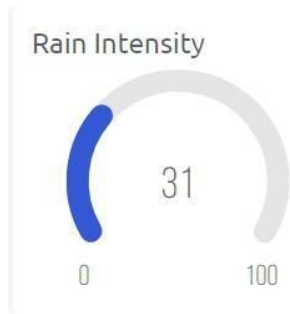

FIG-6.5: Medium Level of water

FIG-6.6: Critical water level

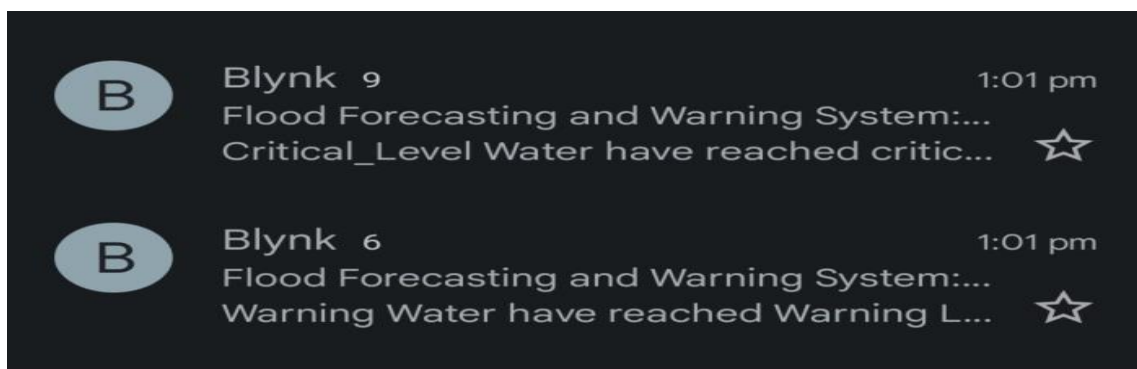

FIG-6.9: Notifications in G-Mail



Notifications in Blynk app

CONCLUSIONS:

This paper is built on creating a smart flood monitoring system with NodeMCU and Blynk application utilizing ultrasonic sensors. Flexibility, efficiency, and cheap cost are provided by the outcomes. A suitable platform for monitoring flash floods and issuing early warnings is a wireless sensor node based on the Blynk platform. In order to detect and give precise sensing data for monitoring and alerting purposes, ultrasonic sensors and a rain sensor connected with

NodeMCU are able to work. Hence, the system shows that it may be utilized for flooding area detection, monitoring, and community warning

REFERENCES

- [1] This paper was published in the Internal Journal of Engineering And Computer Science ISSN:2319-7242 Volume 2 Issue 8 August 2013 Page No. 2332-2336
- [2] DOI https://doi.org/10.1007/978-981-287-988-2_43 Publisher Name Springer, Singapore Print ISBN 978-981-287-986-8
- [3] International Journal of Management and Applied Science, ISSN: 2394-7926 Volume-2, Issue-7, Jul.-2016
- [4] https://www.electronicclinic.com/flood-monitoring-system-with-sms-alert-using-arduino-and-gsm/#Flood_Monitoring_System_Paper_Overview
- [5] This paper was published in the 2011 19th International Conference on Geoinformatics Date of Conference: 24-26 June 2011, by Yan Li Information Center of Yellow River Conservancy Committee, Ministry of Water Resources, Zhengzhou, China, School of Geographic and Oceanographic Sciences, Nanjing University, Nanjing, China Manchun Li, School of Geographic and Oceanographic Sciences, Nanjing University, Nanjing, China
- [6] This paper was published in 2017 International Conference on Smart Cities, Automation & Intelligent Computing Systems (ICON-SONICS) Date of Conference: 08-10 November 2017 by Armi Susandi Meteorology Dept, Bandung Institute of Technology, Bandung, Mamad Tamamadin Meteorology Dept, Bandung Institute of Technology, Bandung.