



ISSN: 2454-9940



**INTERNATIONAL JOURNAL OF APPLIED
SCIENCE ENGINEERING AND MANAGEMENT**

E-Mail :
editor.ijasem@gmail.com
editor@ijasem.org



www.ijasem.org

EVALUATION AND DEVELOPMENT OF A HYBRID HARMONIC SUPPRESSION SYSTEM FOR VSG TAKING NON-LINEAR LOADS AND DISTORTED GRIDS CONSIDERATIONS

¹MR.S.RAJENDER REDDY, ²SARANGI MOUNIKA, ³NENAVATH SURESH, ⁴NALLAMONI GANESH

¹(Assistant professor), EEE. Guru Nanak Institutions Technical Campus, Hyderabad.

^{2,3,4}B.Tech Scholars, EEE. Guru Nanak Institutions Technical Campus, Hyderabad.

ABSTRACT

Virtual synchronous generators (VSGs) will always experience a decline in power quality when there are localized nonlinear loads and a distorted grid. This study initially describes the conflict that arises when trying to simultaneously eliminate distortion for both the grid exchanged current and the local load voltage of the inverter. A customizable tradeoff between the two limited harmonic sources is made possible by a unified control mechanism that is described. Then, in order to further enhance VSG's flexibility, a hybrid harmonic suppression scheme is put forward. This scheme primarily comprises of an adaptive grid current-controlled loop and a local voltage harmonic control loop. The grid current-controlled compensator is designed to counteract the negative effects of a weak grid by providing an additional voltage, while the local voltage harmonic control loop uses a negative feedback loop to reduce the inverter output impedance. This results in significantly lower total harmonic distortion for both the local load voltage and the grid current at the same time. The system's resilience to parameter perturbations and stability are examined by small-signal modeling. Hardware-in-the-loop simulations are used to confirm the efficacy of the suggested technique.

1.INTRODUCTION

These days, power systems are evolving toward a more distributed and power electronics-interfaced paradigm due to the fast growing penetration of distributed generations (DGs). Because of their inertia-less nature, these electrical converters allow distributed generation to operate more freely, but they also present serious risks to the stability and controllability of the system. As a result, the idea of the virtual synchronous generator (VSG) has surfaced and grown in popularity. VSG mimics the rotor inertia and droop characteristics of synchronous generators in distributed generation (DG) applications. Numerous studies have been conducted on The National Key R&D Program of China under Grant 2016YFB0900404, the Fundamental Research Funds for the Central Universities, the Jiangsu Provincial Key Laboratory of Smart Grid Technology and Equipment, Southeast University, and the National Science Foundation of China under Grant 52007031, Jiangsu Province under Grant BK20200404, all provided partial support for this work. Southeast University's School of Electrical Engineering is located in Nanjing, Jiangsu 210096, China, and is home to G. Lou, W. Gu, X. Quan, and S. Li. Additionally, G. Lou works at Southeast University's Jiangsu Provincial Key Laboratory of Smart Grid Technology and Equipment. (glou and wgu at seu.edu.cn) Q. Yang works at the Guangdong Power Grid Company's Dongguan Power Supply Bureau in Guangdong 523000, China, and Southeast University's School of Electrical Engineering in Nanjing, Jiangsu 210096, China. J. M. Guerrero works at Aalborg University's Department of Energy Technology, Center for Research on Microgrids (CROM), located in 9220 Aalborg East, Denmark. VSG with relation to elements like dynamic performance and virtual inertia, stability assessments, parameter optimization, and the VSG concept.

VSG is expected to be an essential component in providing high-quality electricity to both local loads and the main grid, acting as a mellowed method favorable to environmentally friendly DGs. Because of their pulse-width modulation (PWM) and switching nature, power electronics-interfaced distributed generation (DG) systems are often found within recognizable electrical boundaries, where the grid is more susceptible to distortion from the higher permeability of the generation. Furthermore, using nonlinear loads intensively may result in significant harmonic currents even when a pure sinusoidal voltage is applied. Power quality problems, such as overheating, power losses, and mechanical vibrations, are caused by harmonics from a distorted grid and nonlinear load, which limits the use of VSG in the renewable energy sector.

To ensure that the total harmonic distortions (THD) for both local voltage and grid current are low—below 5% in accordance with industry regulations [11]—or, in the best case, completely eliminated, strict schemes must be implemented. Since the majority of VSG literature now in publication focuses on enhancing dynamic performance and very few take power quality issues into consideration, the related study on inverter-related droop control may be considered a reference since both research paths deal with power electronics. Installing active power filters (APFs), which functioned as harmonic conductances, or passive filters was the conventional approach of limiting harmonic currents.

A control system that is susceptible to the dispersion characteristics of DGs and high-precision measurement was put forward. It is based on the injection of distorted currents into the current reference. With an increase in the harmonic impedance, an active branch technique based on voltage feedforward control was devised to significantly reduce harmonic currents. A harmonic droop controller was presented in with marginally better results for harmonic voltage suppression by adding the harmonic voltage from Fourier analysis to the inverter voltage reference. To counterbalance the harmonic voltage drop, a virtual capacitive impedance was introduced, taking into account that the output impedance might be a crucial factor in attenuating THD. With the majority of load harmonic currents being absorbed by inverters, a negative feedforward technique was suggested to reduce the inverter output impedance. Furthermore, a number of intricately implemented control systems based on internal model concept, repeating control, and multiple proportional resonance deadbeat hysteresis were used to limit harmonic voltage and current. It is not difficult to attain low THD for either the grid current or the local voltage of the inverter. Nevertheless, no strategy has been developed to attain low THD for both the local current and the grid voltage simultaneously in the presence of distorted grid and nonlinear loads, as achieving both goals at once seems unfeasible. In particular, when the output harmonic impedance is anticipated to be minimal, it is favorable for the nonlinear load current flowing into the VSG side, but the harmonic component in the grid current would be correspondingly expanded, or vice versa. There hasn't been much study done on the quantitative investigation of this basic constraint.

As mentioned in, due to the dynamic features of VSG in the harmonic domain, the power quality issues with dual harmonic sources are more problematic than those with inverters. As far as we know, in the situation of nonlinear loads and weak grid, an impedance-based harmonic suppression strategy for VSG was developed without closed-loop control; however, since feedforwards are parameter-dependent, their resistance to nonlinear load fluctuation was not adequate. In the event of two harmonic situations, an adequate management method is needed to handle the inverter local voltage and grid current concurrently since important loads are sensitive to the local voltage quality. This work examines the contradiction of concurrent harmonic inhibition for both nonlinear loads and distorted grid statistically, driven by the research gap mentioned above. Next, a hybrid harmonic suppression strategy that is fully compatible with harmonic sources and has a configurable tradeoff is suggested. The suggested scheme's dynamics are examined using a small-signal model.

The following is a list of research contributions. (1) This study presents a unified harmonic control structure with an adjustable tradeoff between the two limited harmonic sources, revealing the main restriction of VSG harmonic inhibition in the presence of distorted grid and nonlinear loads. Using a local voltage feedback control loop and adaptive grid current compensation, a hybrid harmonic suppression approach is suggested to allow the total suppression of the dual distortions. This method can significantly attenuate the harmonics and provide a high-quality power supply for VSG. (3) The

use of a multiple harmonic sequence components observer (MHSCO) [27] makes it possible to precisely and thoroughly identify numerous harmonics at once.

2.HARMONICS

2.1 DEFINITION

"A sinusoidal component of a periodic wave or quantity having a frequency that is an integral multiple of the fundamental frequency" is the standard definition of a harmonic. Some sources define "clean" or "pure" power as having no harmonics. However, clear waveforms like this are usually seen in a laboratory. Harmonics are here to stay and have been for a very long time. Actually, from the creation of the first string or woodwind instrument, musicians have been aware of such. What makes a clarinet sound like a clarinet and a trumpet sound like a trumpet is harmonics, sometimes referred to as "overtones" in music. Electrical generators aim to generate electricity in situations when the voltage waveform exhibits a single frequency, known as the fundamental frequency. This frequency, or cycles per second, is 60 Hz in North America. The standard frequency for this frequency in Europe and other areas of the globe is 50 Hz. 400 Hz is often used as the fundamental frequency in aircraft.

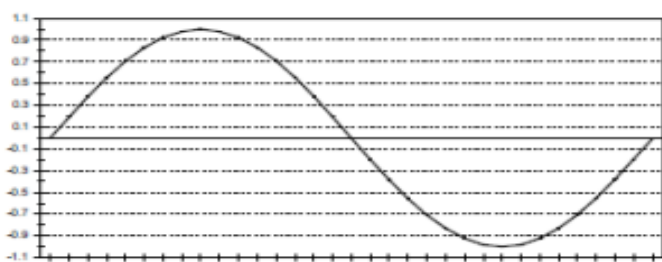

Fig. 2.1: Sine Wave

2.2 PROBLEMS WITH HARMONICS

Harmonics don't always indicate that the office or factory can't function correctly. It is dependent on the equipment's susceptibility and the "stiffness" of the power distribution system, much as other power quality problems. High harmonic voltage and/or current levels may cause a variety of equipment types to malfunction or fail, as the list below illustrates. Furthermore, a plant that is capable of operating correctly might be the cause of excessive harmonics. Harmonic pollution may affect facilities on the same system that are particularly vulnerable because it is often transferred back into the electric utility distribution system.

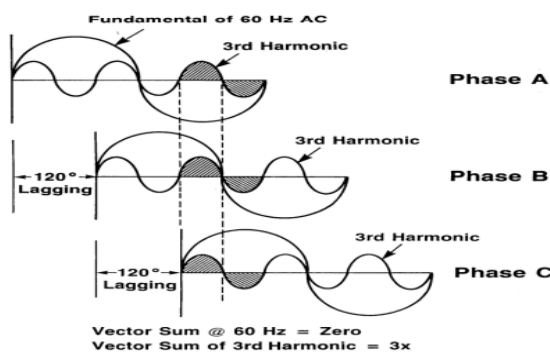

Fig.2.2: Additive Third Harmonics

Table 2.2: Typical Harmonics Found For Different Converters

TYPE OF DEVICE	NUMBER OF PULSE	HARMONICS PRESENT
Half wave rectifier	1	2,3,4,5,6,7...
Full wave rectifier	2	3,5,7,9...
Three phase, full wave	6	5,7,11,13,17,19...
(2) three phase ,full wave	12	11,13,23,25,35,37...

When operating in the presence of harmonics, a transformer should be derated from its nameplate rating by the amount specified in the Recommended Practice for Establishing Transformer Compatibility When Supplying Non Sinusoidal Load Currents.

Table 2.3: Current Harmonic Limit

RATIO Iscc / I load	Harmonics Range	Limit as % of fundamental
Less than 20	Odd number less than 11	4.0 %
Between 20 and 50	Odd number less than 11	7.0 %
Greater than 1000	Odd number greater than 11	1.4 %

As shown in Table III, the voltage level of the system is utilized to calculate the limitations for voltage harmonics. The lower restrictions are due to the fact that more consumers will be effective at higher voltages.

2.3 HARMONIC MITIGATION APPROACHES

Three fundamental methods exist for suppressing harmonic distortion in power distribution systems:

- Passive filter.
- Active power filter.
- Active hybrid power filter.

3.POWER QUALITY

3.1 Introduction:

The idea of powering and grounding sensitive equipment in a way that is appropriate for that equipment's functioning is known as power quality. The huge surge in interest in power quality may be attributed to a variety of factors. Among the primary causes are the following: • The sensitivity of electricity and electronic equipment has increased significantly. Businesses are less tolerant of production stoppages, equipment is less tolerant of voltage quality disruptions, and production processes are less tolerant of improper or erroneous equipment operation.

The primary culprits are voltage dips and interruptions; voltage dips and brief interruptions are the focus of debates in the literature. Periodically, high frequency transients are studied as potential sources of equipment failure. • Equipment is generating more current disturbances than it did in the past. An increasing amount of low- and high-power equipment is powered by basic power electronic converters that result in a wide range of distortion. There are hints that the power system's harmonic distortion is increasing, but the absence of extensive surveys prevents definitive findings from being made.

3.2 Need for Power Quality improvement:

All power utility systems now need sufficient power quality, in contrast to earlier decades of power generation, for the following technological reasons:

1. Companies are less tolerant of production stoppages, equipment is less tolerant of voltage quality issues, and production processes are less tolerant of equipment running improperly. Notice that in discussions, the first issue is often the only one raised, even if the other two could be as important. When even little interruptions happen, all of this leads to expenditures that are much higher than they were before. Voltage dips and interruptions are the main offenders; they are the subjects of discussions in the literature. High frequency transients are seldom addressed as possible causes of equipment failure in the literature, despite the fact that they are rarely covered in depth there.

2. Equipment now disrupts current more than it did before. A broad spectrum of distortion is produced by the fundamental power electronic converters used to power a growing number of low- and high-power devices. There are indications that the harmonic distortion of the electricity system is rising, but conclusive results cannot be reached in the lack of comprehensive assessments.

3.3 Power Quality Standards:

3.3.1 Purpose of Standardization:

There have been standards defining the quality of the supply for many years. Nearly every nation has regulations outlining the permissible ranges for frequency and voltage variations. Other standards provide limits on the length of an interruption, voltage variations, and harmonic current and voltage distortion. The establishment of electricity quality standards serves three purposes.

3.3.2 The European voltage characteristics Standard:

Electricity is referred to be a product under European standards, despite its drawbacks. Under typical operating circumstances, it provides the primary voltage characteristics at the customer's supply terminals in public low- and medium-voltage networks. A broad range of usual values are provided for some disturbances, real voltage characteristics are provided for certain disturbances, and certain disturbances are only noted.

Table representing voltage & frequency limits:

voltage magnitude variations	Shall be between 207 and 244 volts
Voltage unbalance	Should be up to 2%
Voltage fluctuations	Should not exceed flicker level
Frequency	Should be in between 49.5 and 50.5 Hertz

4.VOLTAGE SOURCE CONVERTERS (VSC)

A power electronic device that can produce a sinusoidal voltage with any desired magnitude, frequency, and phase angle is called a voltage-source converter. In addition to being often used in adjustable-speed drives, voltage source converters may also be employed to lessen voltage dips. The voltage may be fully replaced or the "missing voltage" can be injected using the VSC. The discrepancy between the nominal and real voltages is known as the "missing voltage."

The converter is often powered by a kind of energy storage, which provides a DC voltage for the converter. The required output voltage is then obtained by switching the converter's solid-state circuitry. Typically, the VSC is utilized to address additional power quality problems including flicker and harmonics in addition to voltage dip prevention. The voltage source rectifier works by using a feedback control loop, as shown, to maintain the dc link voltage at a specified reference value. The dc link voltage is monitored and compared with a reference VREF in order to complete this operation.

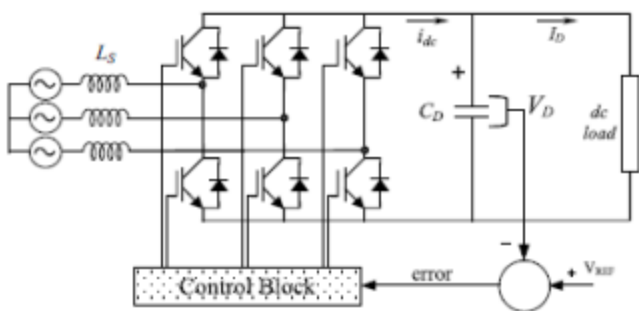

4.2 Operation principle of the voltage source rectifier:

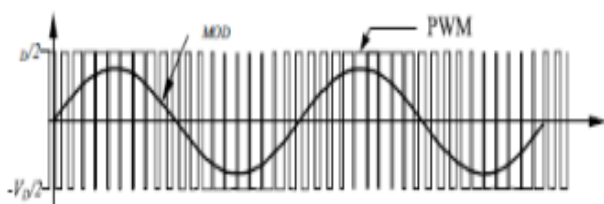

Fig. The rectifier may be operated in four quadrants: leading power factor, lagging power factor, leading power factor inverter, and lagging power factor inverter, using a PWM pattern, its basic VMOD, and its phase-shift with regard to the mains. Altering the modulation pattern, as seen in Fig., affects the VMOD's magnitude. The phase-shift is altered by shifting the PWM pattern. A phasor diagram may be used to visualize the relationship between VMOD and V (source voltage). This interaction makes it possible to comprehend this rectifier's four-quadrant capabilities. The following procedures are shown in fig.: (a) zero power factor capacitor; (b) zero power factor inverter; (c) zero power factor rectifier; and (d) zero power factor inductor. The source current's rms value is shown in Fig. The semiconductors are being driven by this current in the same manner as seen in Fig.

4.3 Three-Phase Voltage Source Inverters:

Low-range power applications are served by single-phase VSIs, whereas medium- to high-power applications are served by three-phase VSIs. These topologies are primarily intended to give a three-

phase voltage source with customizable voltages in terms of amplitude, phase, and frequency. While the majority of applications—such as ASDs, UPSs, FACTS, and var compensators—need sinusoidal voltage waveforms, certain newly developed applications—such as active filters and voltage compensators—also call for arbitrary voltages. The eight legitimate switch states are shown in Table and the typical three-phase VSI structure is displayed. The same as with single-phase VSIs, a short circuit across the dc link voltage supply would occur if the switches of any leg of the inverter—S1 and S4, S3 and S6, or S5 and S2—were turned on at the same time.

5. VSG CONTROL SCHEME

Figure shows the topological structure of the inverter-interfaced DG, where the linear and nonlinear loads are situated at the point of common coupling (PCC) and the inverter functions as a voltage-controlled VSG. By using a static switch (STS) to link PCC to the main grid, the operating mode of the distributed generator may be selected. Filter resistance, inductance, and capacitance are denoted by the letters R_f, L_f, and C_f, respectively; Z_g stands for grid impedance, which is primarily an inductive property; The line impedance between the PCC and the inverter is indicated by Z_{line}; the output voltage and current are represented by u_o and i_o, respectively, and the inverter voltage and current by u_{VSG} and i_i. The grid voltage and current are denoted by u_g and i_g, respectively; the currents of the linear and nonlinear loads are denoted by i_{Load1} and i_{Load2}.

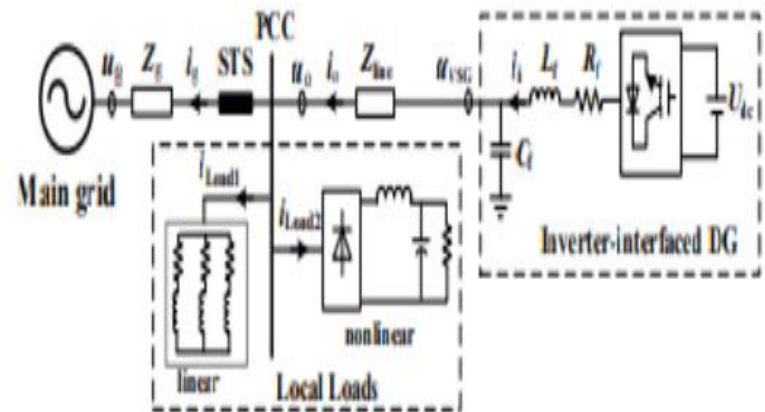

FIG:5.1.1 : Structural diagram of grid-connected DG

5.2 PROPOSED CONTROL SCHEME FOR VSG HARMONIC VOLTAGE AND GRID CURRENT SUPPRESSION

Multi-Harmonic Adaptive Observer To solve this problem, the superposition theorem is used to examine a linear circuit at each frequency independently, as is evident. In this study, an MHSCO is presented to extract the individual harmonic sequences instead of the traditional low pass filter (LPF) since precise harmonic detection is of great importance. It is possible to formulate the estimator designated for the h-th harmonic component [27].

$$\hat{x}_{k+1}^h = e^{j\omega h T_s} \hat{x}_k^h + \frac{\omega C_s}{1 + \omega C_s T_s} (v_k - \sum_n e^{j\omega n T_s} \hat{x}_k^{(n)})$$

6.SIMULATION RESULTS

6.1 SIMULATION CIRCUITS

Without Compensating :

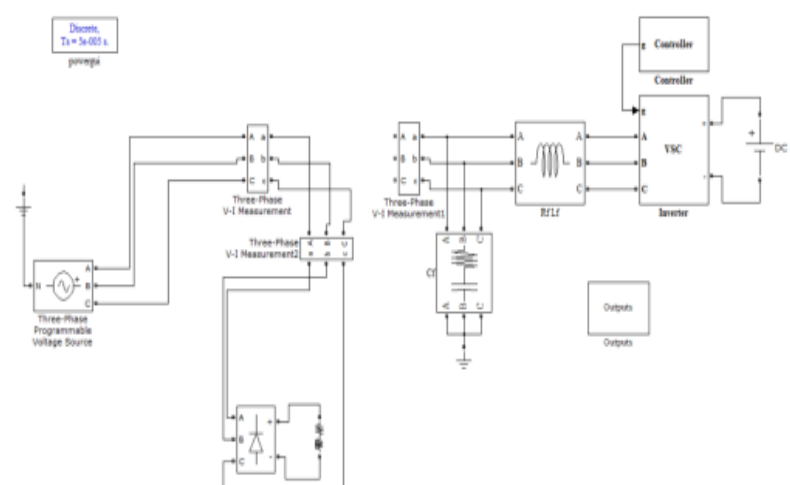

With Compensating :

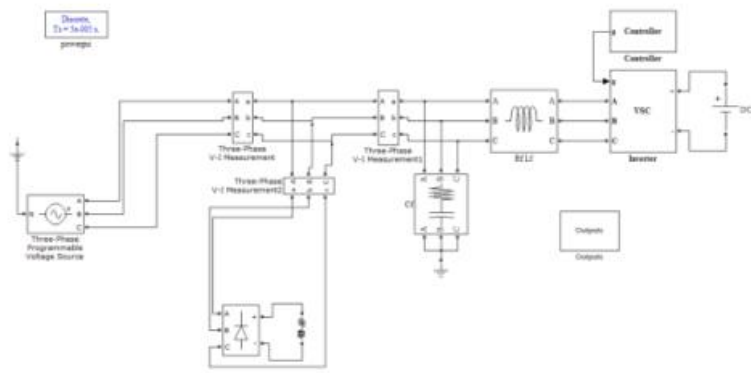

6.2 SIMULATION RESULTS

Without compensating Waveforms of Grid and Load parameters (V & I)

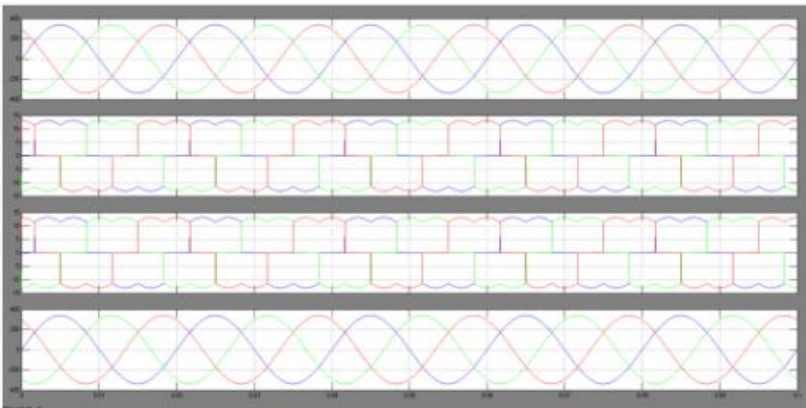

With compensating Waveforms of Grid and Load parameters (V & I)

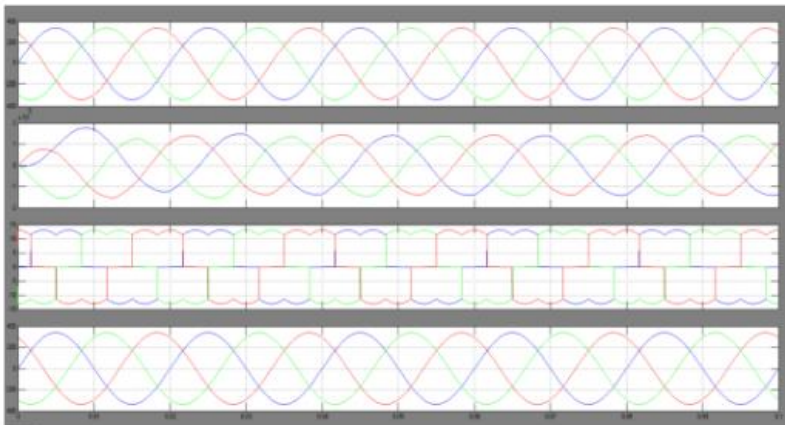

With compensating Waveforms of Active and Reactive power :

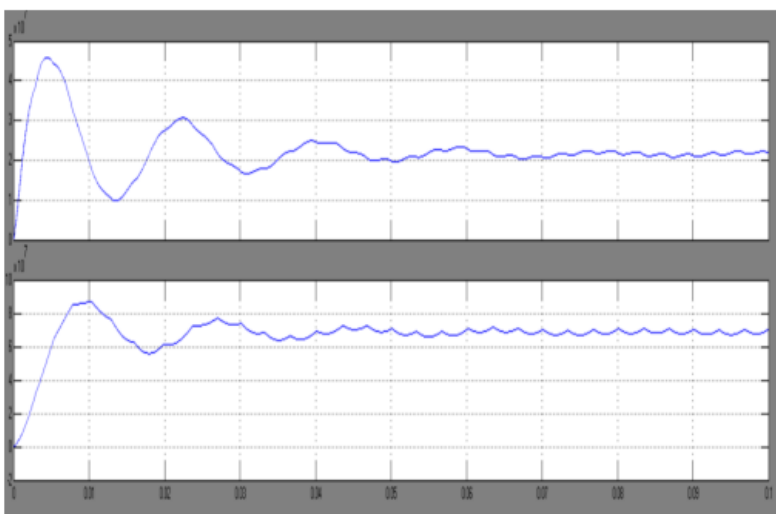

Without compensating Waveforms of Active and Reactive power :

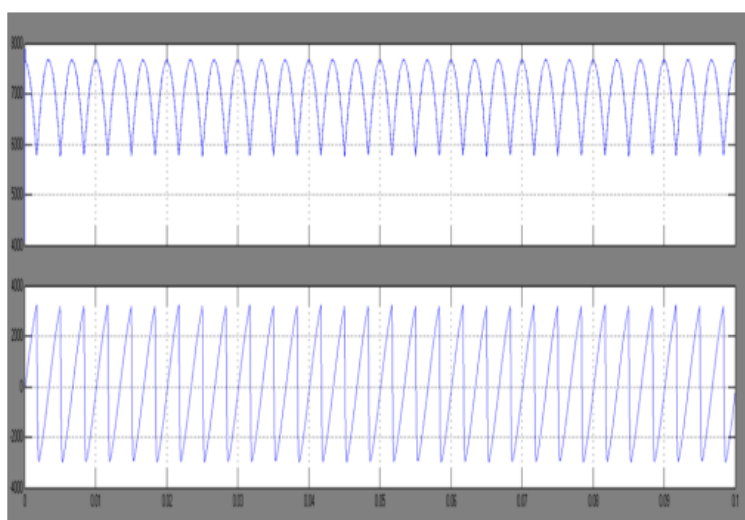

Without Compensating THD% of Grid Current:

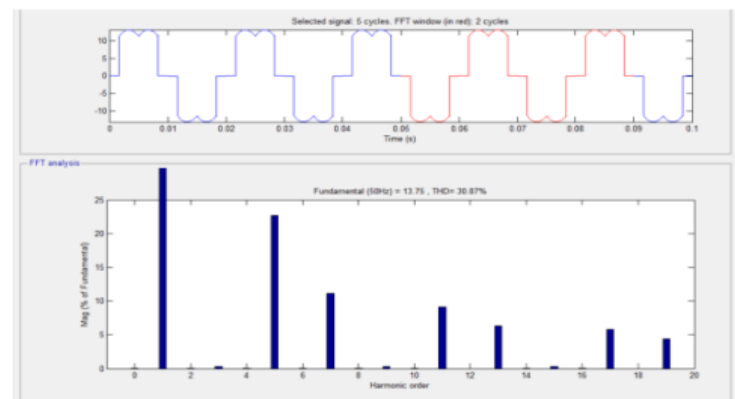

With Compensating THD% of Grid Current:

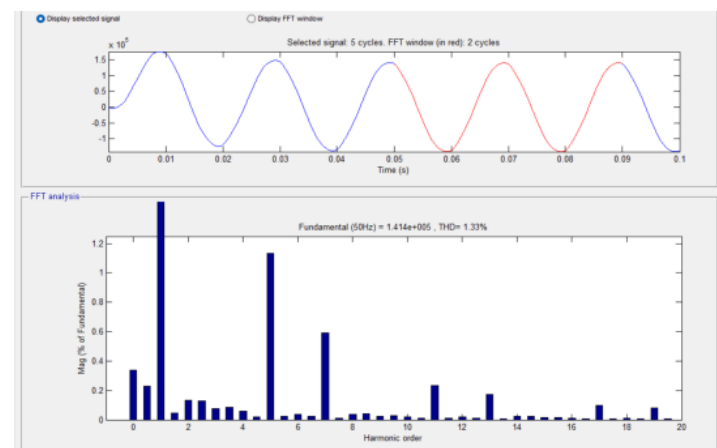

7.CONCLUSION

This study proposes adjustable tradeoff between restricted harmonic sources, given the inherent contradiction involved in attenuating deleterious effects in the presence of nonlinear loads and distorted grid. Next, a hybrid harmonic suppression technique with concurrent distortion inhibition capacity is developed. This scheme comprises of an adaptive grid current-controlled loop and a local voltage harmonic control loop. The suggested technique offers superior power supply for both local loads and the grid as compared to the current methods.

8.REFERENCES

- [1] This article has been accepted for publication in a future issue of this journal, but has not been fully edited. Content may change prior to final publication. Citation information: DOI 10.1109/TEC.2021.3063607, IEEE Transactions on Energy conversion...Analysis and design of harmonic suppression scheme for VSG Considering nonlinear loads and distorted
- [2] J. Ailpoor, Y. Miura, and T. Ise, "Power system stabilization using virtual synchronous generator with alternating moment of inertia," IEEE Journal Emerg. Sel. Topics Power Electron., vol. 3, no. 2, pp. 451-458, June 2014.
- [3] J. Liu, Y. Miura, and T. Ise, "Comparison of dynamic characteristics between virtual synchronous generator and droop control in inverter-based distributed generators," IEEE Trans. Power Electron., vol. 31, no. 5, pp. 3600-3611, May 2016. [4] D. Arricibita, P. Sanchis, and L. Marroyo, "Virtual synchronous generators classification and common trends", in Proc. IECON, 2016, pp. 2433-2438.
- [5] J. Fang, Y. Tang, H. Li, and X. Li, "A battery/ultra-capacitor hybrid energy storage system for implementing the power management of virtual synchronous generators," IEEE Trans. Power Electron., vol. 33, no. 4, pp. 2820-2824, Apr. 2018.
- [6] T. Shintai, Y. Miura, and T. Ise, "Oscillation damping of a distributed generator using a virtual synchronous generator," IEEE Trans. Power Deliv., vol. 29, no. 2, pp. 668-676, Apr. 2014.
- [7] W. Ma, Y. Guan, and B. Zhang, "Active disturbance rejection control based control strategy for virtual synchronous generators," IEEE Trans. Energy Convers., vol. 35, no. 4, pp. 1747-1761, May 2020.

[8] H. Wu, X. Ruan, D. Yang, X. Chen, W. Zhao, Z. Lv, and Q. Zhong, "Small-signal modeling and parameters design for virtual synchronous generators," *IEEE Trans. Power Electron.*, vol. 63, no. 7, pp. 1259-1267, June 2016.

[9] Z. Shuai, C. Shen, X. Liu, Z. Li, and Z. J. Shen, "Transient angle stability of virtual synchronous generators using Lyapunov's direct method," *IEEE Trans. Smart Grid*, vol. 10, no. 4, pp. 4648-4661, July 2019.

[10] J. Chen, T. O' Donnell, "Parameter constraints for virtual synchronous generator considering stability," *IEEE Trans. Power Syst.*, vol. 34, no. 3, pp. 2479-2481, May 2019.

[11] Q. Zhong, and G. Weiss, "Synchronverters: inverters that mimic synchronous generators," *IEEE Trans. Ind. Electron.*, vol. 58, no. 4, pp. 1259-1267, Apr. 2011.