



**ISSN: 2454-9940**



**INTERNATIONAL JOURNAL OF APPLIED  
SCIENCE ENGINEERING AND MANAGEMENT**

**E-Mail :**  
**editor.ijasem@gmail.com**  
**editor@ijasem.org**

**www.ijasem.org**

# Sunlight based Photovoltaic Framework Interconnection Plans with Halfway Shade

<sup>1</sup>Needudoddi Deepthi, <sup>2</sup>P.Obulesu, <sup>3</sup>Mrs.G.Pavanajyothi

---

## **Abstract:**

Photovoltaic (PV) and Concentrated Solar Power (CSP) are two methods for converting sunlight into energy (CSP). In PV, light is converted into energy through the photovoltaic effect by using semiconducting material. There are numerous sources of solar energy, such as photovoltaic, thermal heat, and fuels, all of which provide a safe, abundant, and never-ending supply of energy for humans to harness. Since this technology offers so many advantages, a great deal of study into its development has been done and is now being conducted. For academics and scientists alike, this article will serve as a useful predicting tool for the future of solar photovoltaic energy systems. Partially shaded solar photovoltaic systems are rendered ineffective because the insulation received by the cells is negatively impacted. Altering interconnection patterns is one of numerous methods recommended for reducing the partial shadowing impact. One may find a variety of connecting schemes in the literature

---

## **1. Introduction**

The use of solar photovoltaic systems has expanded significantly during the past several years. Insulation levels, temperature, partial shadowing, and the location of a solar PV system all affect the system's performance. Precise shading is

the most critical of these design aspects. It's possible to have partial shadow when nearby trees, dirt, bird droppings, buildings, and poles reduce the amount of insulation in the cells/modules/arrays[10,11].

---

<sup>1,2,3</sup> Assistant Professor

<sup>1,2,3</sup> Department of Electrical and Electronics Engineering,

<sup>1,2,3</sup> Dr.K.V.Subba Reddy College Of Engineering for Women

---

As a result, the production of cells that are shaded decreases, and this debris accumulates in the Environmental concerns have grown as conventional energy sources have been depleted due to population growth, research, industrial use, and other activities that create waste and pollute the environment. As a result, companies are looking for alternative energy sources and purchasing them to meet the rising demand. This means that renewable energy sources such as and tidal, geothermal, wind, microhydro and biomass, as well as solar power, may be converted into electricity. For solar energy, the sun serves as a major source since it emits both light and heat [9]. Furthermore, by burning and consuming fossil fuels on the Earth's surface, such as petroleum and coal, these fossil fuels emit carbon dioxide emissions that have a negative effect on the ecology and climate. In contrast, no carbon dioxide is emitted by solar power, making it an efficient use of natural resources while also being good to the environment. As the sun shines, it is converted into energy, which may be used in a variety of different ways by a solar power generating system. An estimated 42 trillion kilocalories of energy are emitted by our star each second. per. second. A single hour's worth of power would suffice

for the entire world if we were able to convert all of this 100% solar energy into electrical power. Among renewable energy sources, solar power is the most potent.

"Solar power is described as the conversion of sunshine into electricity, which may be direct by utilizing PV or indirect by using concentrated solar power (CSP)." [7].

either photovoltaic (PV) or thermal (thermal) systems

- (A) Panels installed on the roof or on the ground in a PV system provide direct conversion of sunlight into electrical energy.
- (B) A turbine is used to turn solar thermal energy into electricity in Concentrated Solar Power (CSP) installations [8].

Condensed solar power uses lenses, mirrors, and a tracking system to collect and focus sunlight into a concentrated beam. Direct sunlight is needed for concentrated solar power facilities.. Diffused sunlight is not reflected in this system, making it useless under foggy situations. CSP (concentrated solar power plants) became commercially viable in the 1980s. The 392 megawatt Ivanpah solar power plant in California's Mojave Desert is the world's biggest concentrating solar power plant. There are several benefits to using

concentrated solar energy, such as the conventional distribution network and cheap fuel costs. Nevertheless, the electricity they produce is unpredictable and susceptible, diminishing their usefulness in terms of a source of power. The use of Solar Concentrated Power Systems [1].

As  $I_{sc}$  gets lower, the output performance of the entire solar system suffers as well. So power is dissipated under this circumstance because of a decrease in short circuit current. With consistent shade, however, the solar photovoltaic power voltage characteristics lose their single-power maximum. As a result, significant currents flow through the photovoltaic cells that are shadowed [1,2,7,8]. These cells are operating at reverse voltage in this state. Consequently, the amount of electricity collected from the entire solar photovoltaic array falls during this time period, resulting in a loss in efficiency. Avalanche breakdown is caused by a high bias voltage, which results in thermal breakdown. When this happens, an issue with hot spots develops in the photovoltaic system. Diodes may be used to solve the problem of hot spots. Solar photovoltaic arrays are linked anti-parallel to these devices to reduce reverse voltage and, as a result, power loss in shaded cells. Photovoltaic cells can only be broken down to a lower voltage when reverse voltage is

applied across shaded cells[5]. This bypass diode prevents this. It is possible for cells in a module to follow a different current route when bypass diodes are used. As a result, rather than generating electricity, these cells will dissipate it, resulting in a hotspot problem under partial shadowing. Anti-parallel diodes are employed to lessen the effect [3, 5].

The reconfiguration technique can also be used to overcome the partial shading effect. Shaded modules are re-configured by modules in an adaptive bank in this method. The output power remains constant, even when the modules are shaded. Its disadvantage is that it is expensive and ineffective in making up for all of the shady cells in a photograph [5].

## 2. Interconnection Schemes

There are four different topologies evaluated in this work, including series-parallel (SP) and total-cross-tied (TCT) topologies (fig.1(a), b, and c) (d). Various shading patterns need different settings, therefore it's critical to research how each one behaves in different situations. Modules are linked in series and then in parallel to create the necessary current. [12]. As a result of the SP design, modules are first connected in parallel and then in series utilizing a TCT configuration to provide the

necessary power [6]. A portion of the TCT's connections have been severed in BL's new architecture. [9] Changes are made to the original BL setup in order to create the HC configuration. Although inspired by the honeycomb hexagon, its obliquely hatching blocks have two cells in parallel, while the unhatched blocks only reveal one cell [10]. The number of ties used in an HC setup varies according to the number of modules it contains, therefore there are three basic configurations: two, four, and six [4].

TABLE I. A single solar cell's output information.

Parameter	Value
Short-circuit current, $I_{sc}$	7.34 A
Irradiance, $I_r$	1000 $W/m^2$
Energy gap, $E_g$	1.11 eV
Open-circuit voltage, $V_{oc}$	0.6 V
Quality factor, $N$	1.5
Fixed circuit temperature	25°C

The load cannot be powered by a single solar cell. As a result, solar cells are connected in series and parallel to form modules, and

a) SP

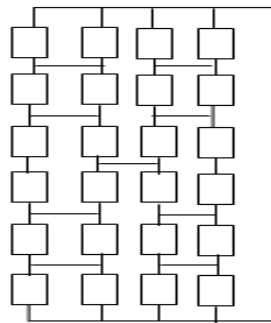
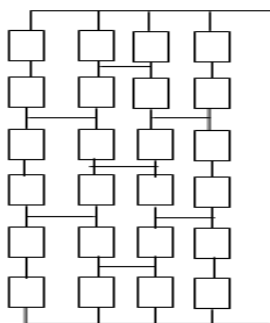

c) BL

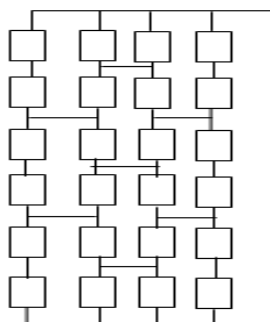

an array is constructed by connecting many of these solar cells in series and parallel to form modules, and

d) HC modules together [6]. However, the ability to include these cells in

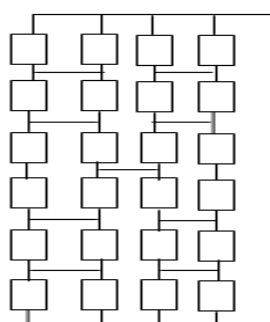

many configurations is impressive. As illustrated in Figure 4, a 6\*4 PV array with a

1000 W/m<sup>2</sup> radiation dose has been modelled using 24 modules.

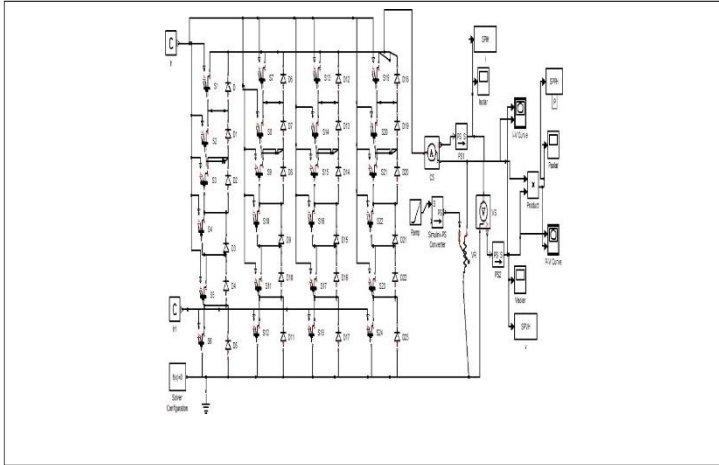
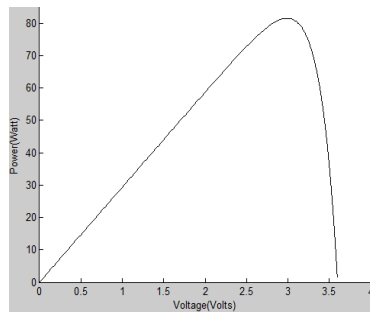

Fig4 : MATLAB/SIMULINK model of a



6\*4 photovoltaic array

a) P-V characteristics

b) I - V characteristics

### Shading Patterns

In this study, a variety of partial shading circumstances are explored to see how alternative configurations might be used to solve the issue. Thus, all 24 solar cell combinations in the SP, TCT, BL, and HC models are simulated. To make a string, six cells are connected sequentially, as seen in figure 4, and these strings are linked together as shown. The simulated modules of these systems are compared in order to find the best architecture for different shading schemes. Many shading patterns are taken into consideration in this research, including the leftmost column in Figure 6(a), the bottom row in Figure 6(b), and the quarter array in Figure 6(c), as well as random shading in Figures 6(d) through (6(f) in the third figure (f). The MPP power, MPP voltage, and MPP current of

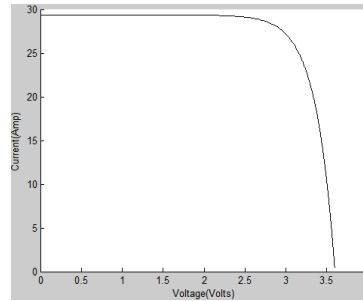

these six shading patterns are computed based on their properties, and the results and observations are taken into account.

a) Columns on the left are

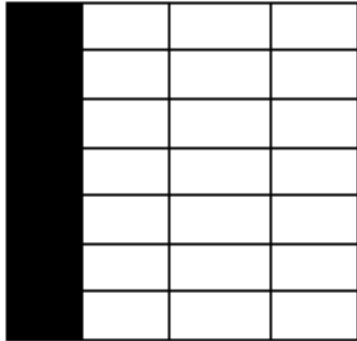

darkened.  
b) dark shadow falls on the bottom row.

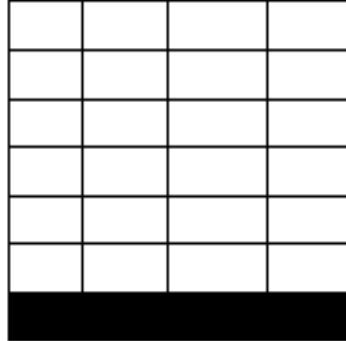

**Results and Discussion**

Figures 6(a) through 6(f) show how I-V and P-V alter with partial shadows. 500 W/m<sup>2</sup> is advised for these gloomy cells.

c) In the dark quarter of the array. d) Unpredictable shading pattern – I

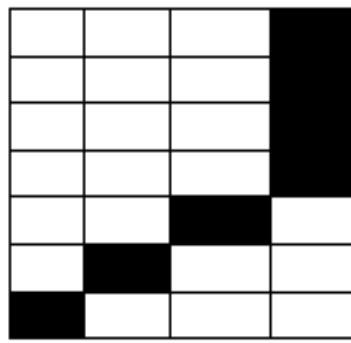
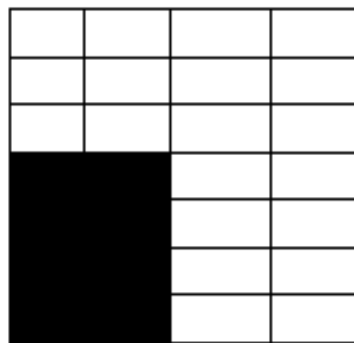

Fig.7.1 : Characteristics of P-V and I-V for the two leftmost columns

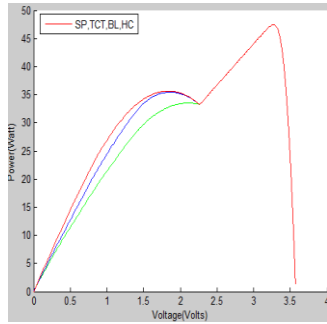
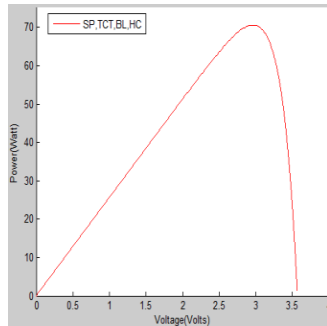

Fig.7.2 :  
Characteristics



of P-V and I-V for the  
bottom row

## Conclusion

We utilized MATLAB/SIMULINK in order to simulate and compare the performance of a number of different configuration types under various partial shading circumstances. These included SP, TCT, BL, and HC. Some studies have found that partial shade enhances the performance of TCT. However, in some circumstances, connectivity can be modified to reduce the number of ties. Reducing the number of connections reduces

cabling losses while also

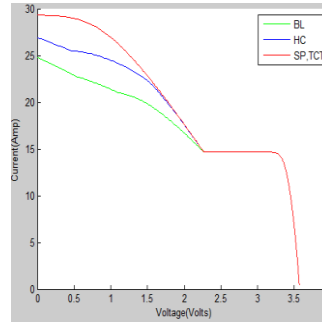

decreasing the time required to connect. SP and BL are also expected to perform better than TCT in some partial shading

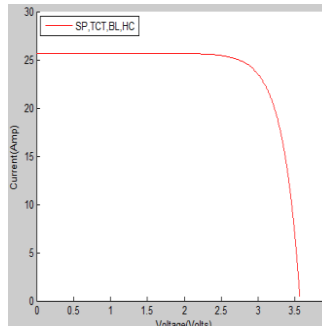

situations.

## REFERENCES

1. Singh Girish Kumar, "Solar Power Generation by PV (photovoltaic) Technology: A Review." Energy, vol. 53, pp. 1-13, 2013.
2. Kelvin Lord, "From Wikipedia: the free encyclopedia" (2001).
3. Parida Bhubaneswari, S\_Iniyan, and Ranko Goic, "A review of solar photovoltaic technologies" Renewable and sustainable energy reviews vol.15, no. 3, pp. 1625-1636 (2011).



4. T.M.Razykov, Takhir M., Chris S. Ferekides, Don Morel, Elias Stefanakos, Harin S. Ullal, and Hari M. Upadhyaya, "Solar photovoltaic electricity: Current status and future prospects" *Solar Energy* 85, vol. No. 8, pp. 1580-1608, 2011.
5. Mani Monto and Rohit Pillai, "Impact of dust on solar photovoltaic (PV) performance: Research status, challenges and recommendations" *Renewable and Sustainable Energy Reviews* 14, vol. no. 9, pp.3124-3131, 2010.
6. Branker Kadra, M. J. M. Pathak and Joshua M. Pearce, "A review of solar photovoltaic levelized cost of electricity" *Renewable and Sustainable Energy Reviews* 15, vol. no. 9, pp. 4470-4482, 2011.
7. Huang B. J., T. H. Lin, W. C. Hung, and F. S. Sun, "Performance evaluation of solar photovoltaic/thermal systems " *Solar energy* 70,vol no. 5 ,pp.443-448, 2001.
8. Mäki, A., & Valkealahti, S. (2012). Power losses in long string and parallel-connected short strings of series-connected silicon-based photovoltaic modules due to partial shading conditions. *IEEE Transactions on Energy Conversion*, 27(1), 173-183.
9. Ramaprabha, R., & Mathur, B. L. (2012). A comprehensive review and analysis of solar photovoltaic
10. array configurations under partial shaded conditions. *International Journal of Photoenergy*, 2012.
11. Bidram, A., Davoudi, A., & Balog, R. S. (2012). Control and circuit techniques to mitigate partial
12. shading effects in photovoltaic arrays. *IEEE Journal of Photovoltaics*, 2(4), 532-546.