



**ISSN: 2454-9940**



**INTERNATIONAL JOURNAL OF APPLIED  
SCIENCE ENGINEERING AND MANAGEMENT**

**E-Mail :**  
**editor.ijasem@gmail.com**  
**editor@ijasem.org**

**[www.ijasem.org](http://www.ijasem.org)**

## DESIGN AND ANALYSIS OF MULTILEVEL INVERTER USING MATLAB

Dr S Vijaya Madhavi<sup>1</sup>, Keerthi. S. B<sup>2</sup>, A. Divija<sup>3</sup>, Amani<sup>4</sup>

<sup>1</sup> Associate Professor&HOD, Dept. of EEE, Malla Reddy Engineering College for Women, Hyderabad.

<sup>2,3,4</sup> Research Student, Dept. of EEE, Malla Reddy Engineering College for Women, Hyderabad

**Abstract**— The inverter is an electrical power converter that converts current directly into alternating current. Traditional two-phase inverters will eventually give us a square wave, which seems to give us unsatisfactory results when compared to the sinusoidal AC waveforms needed for most products in our lives, the square wave is harmonic, thus reducing the work and other effects of the Power system. The current multiphase inverter is an improvement of the basic two-phase inverter, which uses transistors (IGBT, MOSFET) or thyristors as switches, generating a small voltage level when energized and turned on at different times of the gate voltage. More similar to the AC sinusoidal waveform, reducing the overall harmonic distortion and electromagnetic interference, thus increasing the overall efficiency of the system. The multilevel inverter control method, which will try to stabilize the output of the multilevel inverter and thus optimize the MLI process and try to predict the control model, which is a control process that can predict the future before events and therefore control according to its MLI. allows it. To maintain the voltage level regardless of load demand or interference and give us a sinusoidal AC waveform.

**Index Terms**— 5-Level , Cascaded H-Bridge (CHB-MLI), Multi-Level Inverter , Power Electronics, Predictive Model Control , Harmonic Distortion .

### I. INTRODUCTION

With the advancement of Power Electronics in the last Four Decades which has led into a development in the Multi-Level Inverters especially from the 1980's [1] [2] , the Multi – Level Inverters by using semi-conductor switches can synthesize a waveform with Voltage steps which gives us a Waveform which has less harmonics and also limits the voltage stress ( dv / dt ) stress applied on load [3] .

As demand for electric power has soared along with the demand for Electric Power generated by Renewables which tend to produce Electric Power in DC whereas most of the load in residential , commercial and industrial requires AC Power thus more interest has been given to Inverters

pecially Efficient Inverters which also should have a reduced Total Harmonic Distortion (THD) by having a better waveform . Thus Multi – Level Inverters have gotten more important . The Multi – Level Inverter has been classified into Three Main Topologies ; Diode-Clamped Multi-Level Inverter ,Flying Capacitor Type [3] and Cascaded H-Bridge Multi-Level Inverter [4]. There are other Topologies but they are the combination of the three main Topologies and thus called the Hybrid Topologies . This Research has been conducted on the base of the Five – Level Cascaded H-Bridge Multi-Level Inverter ( CHB – MLI ) which produces five Voltage steps . The new Control Method this research has proposed is the Model predictive Control which will be able to predict future events and be able to stabilize the output .

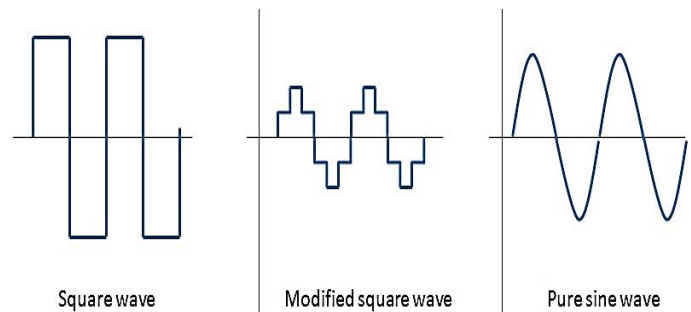

Figure 1.

Left side Waveform shows the output of a conventional Inverter , middle waveform shows the output of a Multi Level Inverter and the right side waveform shows the Pure sine wave required by most devices . As we can see from these waveforms

### II. Five-Level Cascaded H-Bridge Multi-Level Inverter (CHB - MLI) :

In this research the Cascaded H-bridge Multi-Level Inverter (CHB-MLI) which is a topology of Multi – Level Inverter consisting of a cell of 4 semi - conductor switches connected to each other . These semi-conductor switches can be Transistors like MOSFETs (Metal Oxide Semi-conductor Field Effect Transistor) , IGBTs ( Insulated Gate Bipolar Junction) or Thyristors like SCR (Silicon Controlled Diode ) . The difference between the Transistor and Thyristors is that Thyristors are used for high power applications whereas

<https://doi.org/10.5281/zenodo.14065403>

transistors are designed for low voltage and current operation in mind thus using transistors in inverters as Semi-Conductors should only be for low power operation whereas Thyristors used in Inverters should be for high – power Applications .

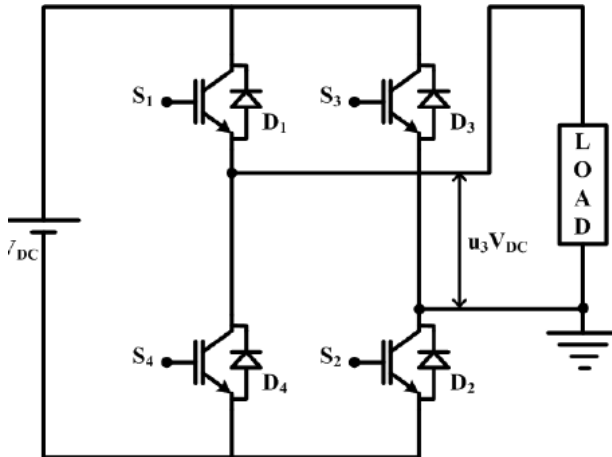

Figure 2.

Basic Cascaded H-Bridge Multi-Level Inverter (3 – Level)

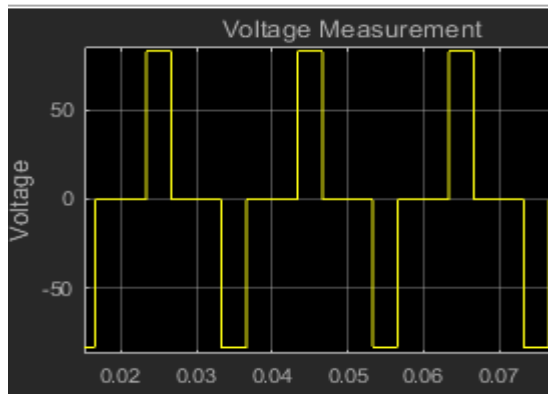

Figure 3 .

Waveform of 3-Level CHB-MLI

Beginning from Three – Level which only consists of Four Semi-Conductors connected together every additional cell cascaded increases the level by two . Thus each cell cascaded gives two extra Voltage steps decreasing the Total Harmonic Distortion and increasing Efficiency . Each cell also requires it's own DC Source .

The reason the Cascaded H-Bridge Multi – Level Inverter was used in this research was :

- It is modular meaning it can be easily expandable [5] by one cell after another to synthesize 2 extra voltage steps for each cell cascaded.
- It can give a waveform quite similar to a sinusoidal waveform without needing a filter when compared to other types Multi – Level Inverters
- It removes the need for bulky Transformer .

- It needs less number of components compared to Diode-Clamped or Flying Capacitor types of Multi – Level Inverter .
- CHB-MLI can work at lower switching frequencies which means decreased losses due to switching which in turn means increase in efficiency during operation .

Thus considering the many benefits of Cascaded H-Bridge , this research has used the Cascaded H-Bridge to create a Model Predictive Controller for the purpose of Design and Analysis of the Multi – Level Inverter .

When selecting the level of the Cascaded H-Bridge ,we need to find out the number of semi-conductor switches which are required , as noted previously we can only choose increasing levels of 2 (i.e. 3 , 5 , 7 ,9 and so on . ) with each increase requiring another cell to be cascaded .

So from this the equation of semi-conductor switches required can be found :

$$S_n = 2(n-1)$$

Where  $S_n$  is the number of semi-conductor switches required.

Where  $n$  is the number of levels we have chosen.

Thus when choosing a 9-level CHB-MLI we would require :

$$S_n = 2(9 - 1)$$

$$S_n = 2(8)$$

$$S_n = 16.$$

Thus the semi-conductor switches required are 16 and to see the number of cells that would be cascaded , we would divide by four ; so 16 divided by 4 gives us four showing that four cells of four semi-conductor switches needed to be cascaded with each other .

In this research we used Five – Level Cascaded H-Bridge Multi-level Inverter for experimentation and analysis .

The reason 5-level CHB – MLI was chosen was that the 3 – Level although simple tended to have higher Harmonic distortion and whereas 7-level and above while possessing less Total Harmonic Distortion would become more complicated and expensive for physical modeling thus finally the Five – Level Cascaded H-Bridge Multi Level Inverter was chosen as it was neither too complex and could easily demonstrate our novel control method which we developed.

<https://doi.org/10.5281/zenodo.14065403>

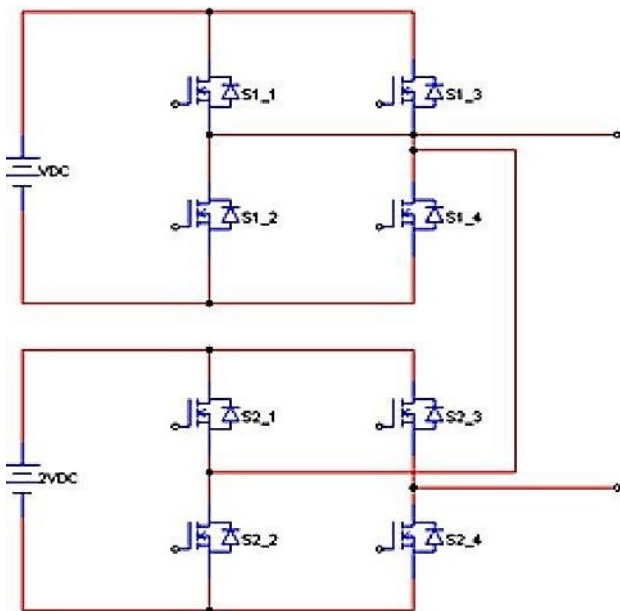

Figure 4 .

5 - Level Cascaded H – Bridge Multi-Level Inverter .

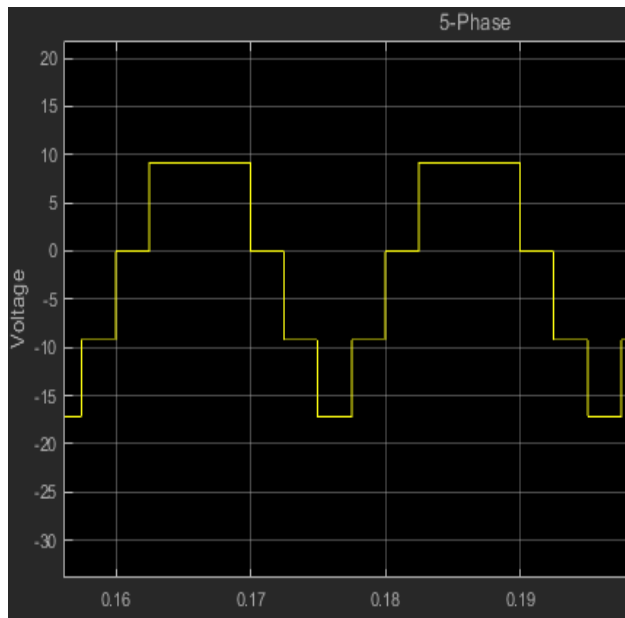

Figure 5 .

Waveform of 5-Level (CHB-MLI)

When designing the five – level Cascaded H – Bridge Multi - Level Inverter , MOSFETs were used as semi-conductor switches as they are designed to operate on low – power at 50 A , whereas IGBT and Thyristors are complicated to use thus were neglected .

### III. Model Predictive Control (MPC)

Over the Years there have been many control methods developed for Multi – Level Inverter mostly based on Pulse

Width Modulation Technique ( PWM ) [7] and Selective Harmonic Elimination (SHE) [8] , which all aimed to control and run MLI’s as well trying to reduce Harmonic Distortion . These techniques usually have only linear Control ability which can only allow them to have limited control over disturbances (i.e. sudden application of load etc.) . Thus Model Predictive Control (MPC) is used in this research which allows us to have non-linear control of the system , set constraints and control the systems output through a feed back loop which produces a change in input based on output to give us as close to ideal output as possible and this control function has a fast dynamic response to the changes in the system [8] – [9] .

There are various types of Model Predictive Control (MPC) , the type used in this paper is Finite Control Set Model Predictive Control (FCS-MPC) which has a shorter control cycle time to get a control performance that is similar to linear controllers but the linear controllers tend to have simple calculations whereas Finite Control Set MPC tends to have a complex calculation required for it’s control process to work . Finite Control Set has no need of Pulse Width Modulation Technique and for every control closed loop cycle only has one switching state [7] .

The Finite Control Set does not work in continuous time but in discrete time , it optimizes the system by looking at the number of switching states the system has and then selecting the switching state which minimizes the error , the error is the cost function (i.e. the difference between output and input ) which then through the use of feed back loop fixes it .

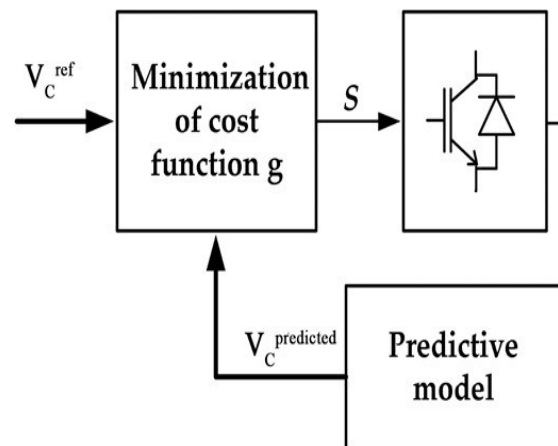

Figure 6 .

Simple Block Diagram of FCS-MPC

As we can see in the above figure , the Predictive models feedback loop first gives the error which is then corrected to give the required switching state to semi-conductor so that the overall system works in proper condition .

<https://doi.org/10.5281/zenodo.14065403>

The circuit which uses the FCS-MPC consists of a 5-Level Cascaded H-Bridge as well as a RC Filter connected to it which is then connected to a load .

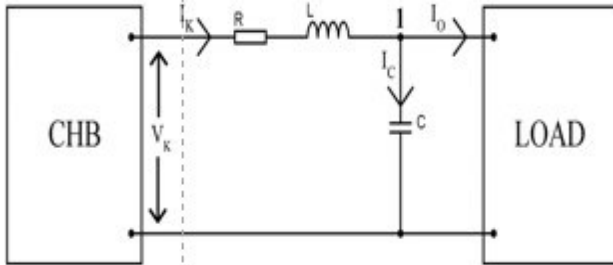

Figure 7 .  
Circuit Diagram .

The operating Principle of this control method is simple , the capacitor voltage on RC filter is controlled through which future predicted voltage is corrected by controlling the voltage in capacitor voltage .

#### IV. SIMULATION MODEL

The Control Method was simulated in Mat lab Simulink , consisting of



Figure 8 .  
Selector Function .

This is the selector function which gives out Voltages based on inputs it was provided with .

These inputs are affected by feedback loop correction .

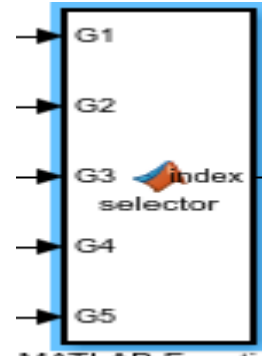

Figure 9.  
Voltage level selector .

This function block in Simulink selects voltage levels ( 0V , 12V , 24V , -12V , -24V ) which will produce the least amount of error .

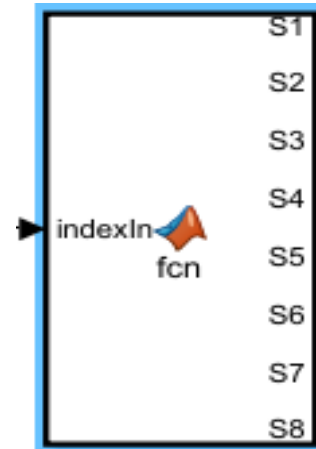

Figure 10.  
Switching state selector .

This function block will provide the switching states to the semi-conductor based on the least amount of error .

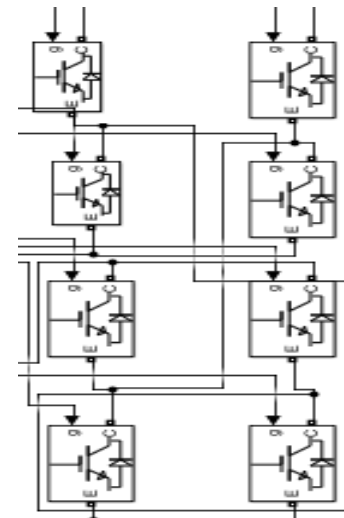

Figure 11.

5-level CHB-MLI

The above figure shows TWO cells of 4 MOSFETs cascaded with each other which are switched on by the switching state selector .

The 5 – Level ( CHB-MLI ) is then connected with a RC Filter which filters the modified square waveform to a sinusoidal waveform which is then connected to a step-up Transformer to step up the voltage to 220 V .

The final Load Waveform given is :

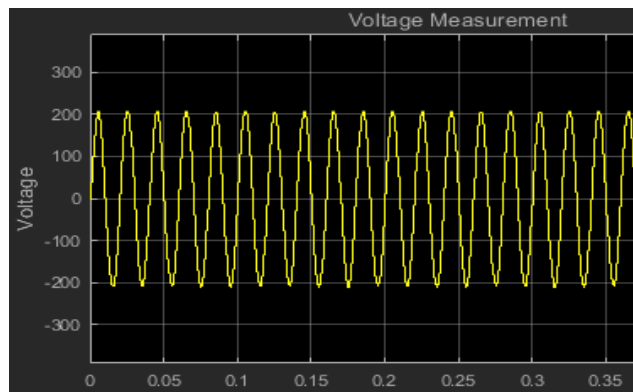

Figure 12 .

Output Voltage Waveform .

As we can see from the voltage waveform , we get a near perfect Sinusoidal Waveform with Total harmonic Distortion less than 1% .

V. FUTURE WORKS

The control method applied in this research paper was based on a Voltage Source Inverter ( VSI ) thus in future work can be done on a Current Source Inverter to apply the Model Predictive Method to get Constant Current which could be used for Industrial Purposes .

Fault Analysis could also be performed on the Model Predictive Controller in future works.

VI. CONCLUSION

This paper used Model predictive Control Method which is a non-linear control method to control and analyze the 5-level CHB-MLI . It used the Finite Control Set method which although more complex requires less time to achieve the control efficiency that other linear controls require to effectively control the system and improve it's efficiency . The FCS – MPC controlled the switching states and voltage levels of the 5-level CHB – MLI to reduce error and select the switching state with the least error . The FCS-MPC has fast dynamic control , allows for constraints which negate it's disadvantages and by applying on the 5 – level CHB-MLI , sinusoidal wave with low Total harmonic Distortion is gained ( i.e. less than 1% ) .

VII. CONFLICT OF INTEREST

The Authors of this research paper declare that there is no conflict of Interest .

VIII. AUTHOR CONTRIBUTIONS

Azan Shah put forth innovative points and wrote the paper , Abdul Ghani Zour and Zain ul Abdin did the experiments .

IX. REFERENCES

- [1] R. H. Baker, "High-voltage converter circuit,"U.S. Patent 4 203 151,May 1980 .
- [2] A. Nabe, I. Takahashi, and H. Akagi , "A new neutral-point clamped PWM inverter, "inProc. IEEE Industry Applications Society Conference, Sept./Oct. 1980, pp. 761–766.
- [3] Patricio Cortés, Alan Wilson, Samir Kouro , Jose Rodriguez, Haitham Abu-Rub , " Model Predictive Control of Multilevel Cascaded H-Bridge Inverters" in IEEE TRANSACTIONS ON INDUSTRIAL ELECTRONICS, VOL. 57, NO. 8, AUGUST 2010 , pp 2691-2699 .
- [4] J. Rodriguez, S. Bernet , B. Wu, J. O. Pontt , and S. Kouro, "Multi-level voltage-source-converter topologies for industrial medium-voltage drives , "IEEE Trans. Ind. Electron., vol. 54, no. 6, pp. 2930–2945,Dec. 2007.
- [5] J. Wen and K. M. Smedley, "Synthesis of multilevel converters based on single- and/or three-phase converter building blocks, "IEEE Trans. PowerElectron., vol. 23, no. 3, pp. 1247–1256, May 2008.
- [6] B. P. McGrath and D. G. Holmes, "Multicarrier PWM strategies for multilevel inverters, "IEEE Trans. Ind. Electron., vol. 49, no. 4, pp. 858–867, Aug. 2002.
- [7] J. Rodriguez, J. Pontt, P. Correa, P. Cortes, and C. Silva, "A new modulation method to reduce common-mode voltages in multilevel inverters, "IEEE Trans. Ind. Electron., vol. 51, no. 4, pp. 834–839, Aug. 2004.
- [8] J.Scoltock , T.Geyer , and U.K.Madawala, "A comparison of model predictive control schemes for MV induction motor drives, "IEEE Trans. Ind. Inf., vol. 9, no. 2, pp. 909–919, May 2013.
- [9] C. Xia, M. Wang, Z. Song, and T. Liu, "Robust model predictive current control of three-phase voltage source PWM rectifier with online disturbance observation, "IEEE Trans. Ind. Inf., vol. 8, no. 3,pp. 459–471, Aug. 2012
- [10] M. Khenar , A. Taghvaie , J. Adabi , M. Rezaejad, "Multi-level inverter with combined T-type and cross-connected modules", IET Power Electron:The Institution of Engineering and Technology, pp. 1-9, 2018.
- [11] M. Daula Siddque, "Low Switching Frequency Based Asymmetrical Multilevel Inverter Topology With Reduced Switch Count "IEEE Access, vol. 7, pp. 86374- 86383, 2019.
- [12] P. Omer, J. Kumar, B. S. Surjan, "A Review on Reduced Switch Count Multilevel Inverter Topologies", IEEE Access , vol. 8, pp. 22281 – 22302, Jan 2020.