



ISSN: 2454-9940



**INTERNATIONAL JOURNAL OF APPLIED
SCIENCE ENGINEERING AND MANAGEMENT**

E-Mail :
editor.ijasem@gmail.com
editor@ijasem.org

www.ijasem.org

TREATING WATER IN THE JAKUBANY PLANT CORROSION TEST

¹KOSURI KRISHNA KUMARI,

²KOTHA SIREESHA,

³NEELAPUDI RAJESWARI,

⁴GADDAM SREEDEVI,

Abstract

Structural degradation in all metallic pipelines is primarily caused by external corrosion, which is dependent on both environmental and operational factors. On the other side, internal corrosion may seriously impair a distribution system's functionality (hydraulics, water quality). Corrosion of water pipes has a significant impact on the long-term performance and reliability of water systems. STN 75 7151 and ASTM D2688-11 are used to assess the test. At the Jakubany water treatment facility, corrosion experiments were conducted on raw and processed water.

Keywords: Changes in the water quality, corrosion, incrustations, and treatment all contribute to this.

INTRODUCTION

When it comes to water supply systems, there are several variables at play. It's also an expensive system with a limited lifespan due to the depreciation of the materials utilised. This affects the dependability of water delivery systems as well as the quality of water provided for human use. Water delivery systems were established at a time when water usage was expected to rise. Water supply systems are overbuilt as a result. This may have a detrimental impact on the sensory properties of the provided water and could lead to microbial contamination if the water consumption is reduced in overdesigned supply systems. Transporting water through a water supply network may lead to a reduction in water quality because of the interaction between water and pipeline components (Vreeburg 2007) [1]. Operators (businesses) of water delivery systems that use metal pipes are often confronted with this issue. corrosion occurs in water delivery systems, which has a detrimental effect on the quality of the water (Munka 2005). Water and pipe material interactions generate electrochemical reactions, which are the primary cause of corrosion. Materials decompose and degrade when they are subjected to the oxidation and reduction processes of redox (Slavková, 2006) [3]. Stagnation period was shown to have a significant effect on metal concentrations, according to Lytle and colleagues [4]. Metal surfaces may benefit from high flow velocities, which help to disperse protective

Dept.: Humanities & Science

Pallavi Engineering College,

Kuntloor(V), Hayathnagar(M), Hyderabad, R.R. Dist.-501505

chemicals more efficiently. As a consequence, high flow velocities may mechanically erode the wall coating and pipe material, resulting in erosion corrosion or impingement assault. Increasing dissolved oxygen contact rates between pipes and pipe surfaces owing to high flow rates may have an impact on corrosion rates.. When it comes to water supply systems, there are several variables at play. It's also an expensive system with a limited lifespan due to the depreciation of the materials utilised. This affects the dependability of water delivery systems as well as the quality of water provided for human use. Water delivery systems were established at a time when water usage was expected to rise. Water supply systems are overbuilt as a result. By reducing the amount of water used in oversized water supply systems, the water retention time is extended, which may have an adverse effect on the water's sensory quality and lead to microbial contamination. While flowing through the water supply system, there is the potential for water quality degradation due to the interaction between water and pipeline components (Vreeburg 2007) [1]. Operators (businesses) of water delivery systems that use metal pipes are often confronted with this issue. corrosion occurs in water delivery systems, which has a detrimental effect on the quality of the water (Munka 2005). Water and pipe material interactions generate electrochemical reactions, which are the primary cause of corrosion. Materials decompose and degrade when they are subjected to the oxidation and reduction processes of redox (Slavková, 2006) [3]. Stagnation period was shown to have a significant effect on metal concentrations, according to Lytle and colleagues [4]. Metal surfaces may benefit from high flow velocities, which help to disperse protective chemicals more efficiently. As a consequence, high flow velocities may mechanically erode the wall coating and pipe material, resulting in erosion corrosion or impingement assault. Increasing dissolved oxygen contact rates between pipes and pipe surfaces owing to high flow rates may have an impact on corrosion rates.

WATERAGRESIVITY DETERMINATION

Chemical water assessments using a direct CaCO₃ test, different computations, or corrosion tests may identify whether water has corrosive effects or not. There are benefits to using chemical analyses to

determine the water aggressivity, such as the ability to conduct frequent testing, which allows for regular monitoring of water quality, and the ability to quickly receive findings. Test results and water quality changes may be compared. Contrary to popular belief, the water aggressiveness calculations include just the water aggressiveness that is a result of aggressive CO₂. When it comes to corrosion, there is no way to calculate how much dissolved oxygen water contains or how fast it is moving, which might have a big impact. STN 75 7151 "Requirements for quality of water in pipe systems" [11] specifies the corrosion test technique, which is based on detecting mass decreases of tested samples 30 and 60 days after exposure to flowing water. 42x42 mm coupons with a 1 mm thickness are utilised in the testing. Corrosion velocities may be determined based on corrosion decrement measurements. The velocities indicate that pipe wall thickness has decreased. The test is extended to a year if the corrosion type and corrosion decrement must also be determined. The benefit of this test comes from the fact that water's influence on sample testing is as complicated as water's effect on the pipeline itself. It is possible that the presence of dissolved oxygen in water might cause corrosion or passivation of metal by generating a protective layer that separates the carried water from the pipeline surface (Dubová et al., 2010) ([12]. STN 75 7151 formulae were used to calculate the corrosion rate based on the decrement of testing coupons. According to the following formula, the average corrosion decrement (g·m⁻²) is determined as an arithmetic average of five testing coupons set in one

$$K' = \frac{1}{n} \sum_{i=1}^n K_i$$

coupon holder

The calculation of corrosion decrements of particular samples in g·m⁻²

$$K = \frac{m_1 - m_2}{S}$$

CORROSION TEST AT THE WTP JAKUBANY

At the Jakubany water treatment plant (WTP) in the Staráubová District of the Czech Republic, corrosion experiments were carried out in partnership with the firm PVPS, a.s. (Podtatranská Water Operating Company) (Fig. 1). The Jakubianka stream is used to collect raw water, which is then piped to the water treatment facility through a DN 500 pipeline. There is a treatment facility in place that can create 150 litres of water per second.. Currently, roughly 60 litres per second are produced. The Jakubany treatment plant's water treatment technique changes with the seasons. Due to ice-cover development, the detritus tank is closed and the sole treatment of water is performed by employing pressure filters throughout the winter.



Fig. 1 WTP in Jakubany

Depending on the condition of the water, the WTP in Jakubany selects a treatment technique. When raw water quality is compromised, the WTP in Jakubany employs a mechanical precleaning procedure, simple sedimentation, and subsequent 1-step coagulative filtering. Pressure mixing tanks are used to add aluminium sulphate, a coagulation reagent, and the resulting flocks are removed using pressure sand filters. A tank with a size of 2500 m³ holds gaseous chlorine or chloramination, which ensures the safety of filtered water. Using gravity pipelines, the water travels from the tank to the drinking area. Corrosion of the water supply pipeline is being monitored over an extended period of time in this project. Between the 11th and 12th of May, 2013, a series of measurements was carried out. The operational categorization of water's aggressiveness was achieved via the use of two instruments that detect corrosion velocity. STN-compliant coupons were utilised for testing on one device, whereas ASTM-compliant

coupons were used for testing on the second. At the WTP's raw water intake site, these devices were installed downstream of the pressure filters and before to disinfection processes. (Fig. 2).

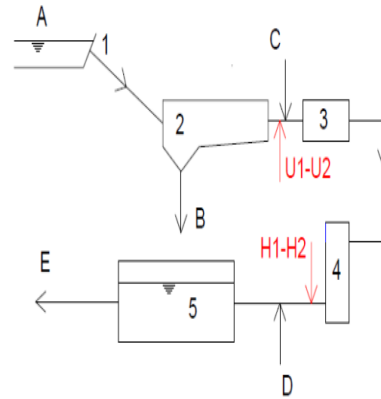

Fig. 2 Technological scheme of WTP in Jakubany

Diffusion of aluminium sulphate C Drainage of settled muck E Water disinfection E – water storage pipe According to STN and ASTM standards, corrosion equipment is referred to as U1,H1 and U2,H2. Sampling equipment 1, sedimentation tank 2, pressure mixing tank 3, press sand filter 4, accumulation tank 5, During the replacement of corrosion devices' testing coupons, the water quality was also examined. Jakubany WTP water quality did not alter considerably in terms of chemical changes. It had pH 7.22-8.32, a temperate range of 0.02–17 oC and quality values for KNK_{4,5} of 1.4–2.2 mmol.l⁻¹, ZNK_{4,5} of less than 0.06 mmol.l⁻¹, Fe of 0.08–0.067 mg.l⁻¹, Mn of 0.01 mg.l⁻¹, and Ca²⁺ of 28.1–40.5 mg.l⁻¹. In the range of 0.00-1.60 ZF, raw water turbidity was reported. Temperature measurements are shown in Fig. 3. The year's average temperature

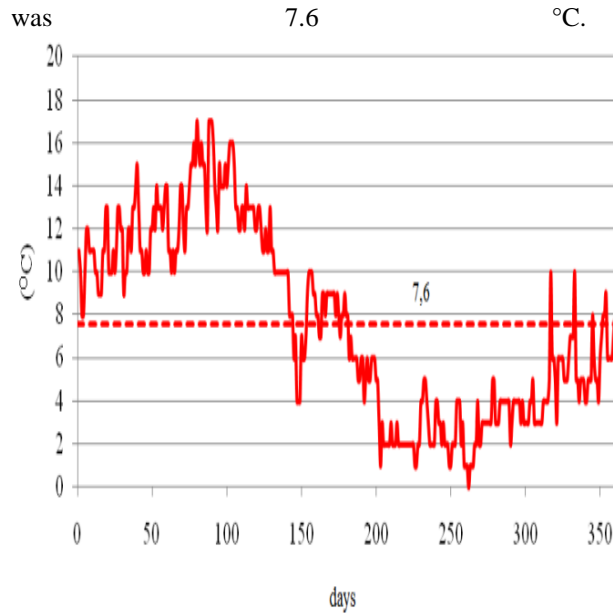

Fig. 3 Water temperature progress in a period of 11.5.2013 - 12.5.2014

RESULTS

Results according to STN

It is clear that the corrosion velocities of raw and treated water are different, based on the results of the tests. Corrosion velocities between 30 and 60 days are shown in Fig. 4. The water is divided into two aggressivity levels, I and II, based on the standard findings. The corrosion velocity of raw water was greater in the first two experiments (5/13 and 6/13) than it was when treated water was used. Storm-related turbidity may have led to a reduction in water flow through the corrosion equipment, which may have resulted in this. The rate of corrosion accelerated in the fifth and ninth tests. Corrosion velocities of water that completed the treatment process were greater than the velocities of raw water in seven experiments, which might be due to a higher flow rate, disinfection reagent (gaseous chlorine), or coagulant reagents (aluminium sulphate).

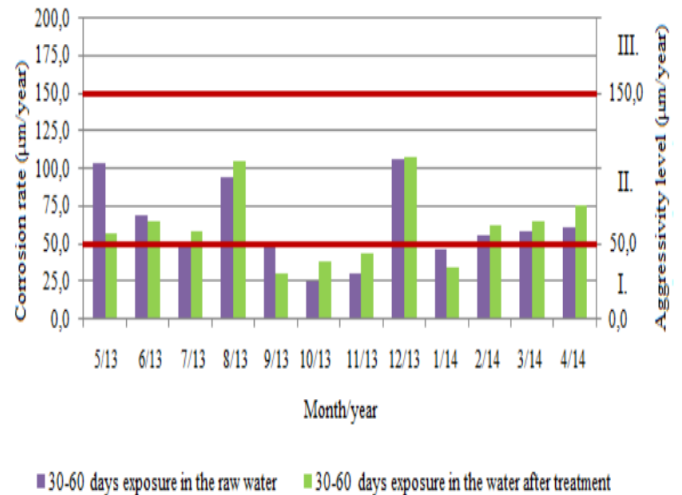
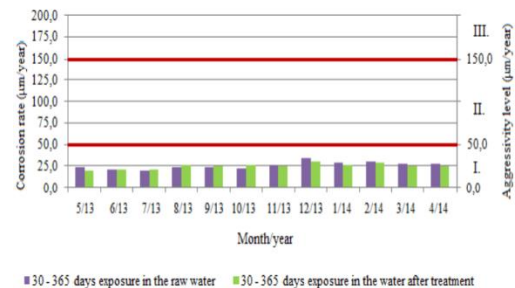

Fig. 4 Consideration of corrosion velocities of raw water and water which passed treatment after 30-60 days of measurements

When utilising raw water and water that has been treated for 30 to 180 days, corrosion velocities may be compared in Figure 5. When a considerable rise in corrosion velocity is seen in water following treatment tests number 5/13-8/13, the findings correspond to linear development in corrosion velocity. The decreased corrosion velocity of water, compared to the typical 30-60 days of observation, indicates aggressivity level I.



Raw water corrosion vs treated water corrosion velocity data over a 30-365 day period are shown in Fig. 6.

Figure 6 depicts the corrosion velocities of raw water and water after treatment throughout the course of 30 to 365 days of experimentation/measurement. Aggressivity level I water is based on yearly corrosion velocity data, which are lower than the 30-

60 and 30-180-day values, and are thus classed as "aggressive." It's possible to see in Figure 7 how the rate of corrosion changes with temperature over the course of a 30- to 60-day period of time when raw water and treated water are compared side by side.

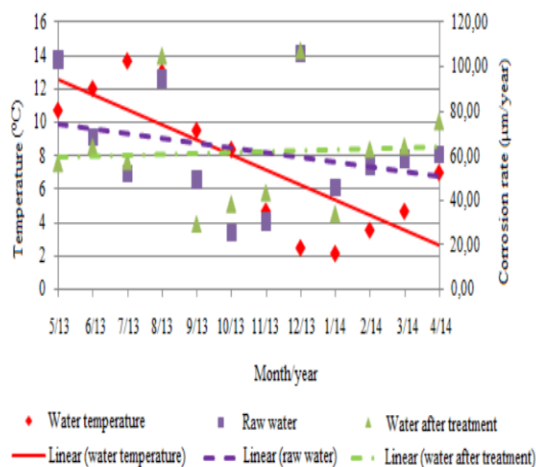

Corrosion velocities of raw water and water treated after filtration measured during 30-60 days in relation to temperature progress (Fig. 7).

An yearly exposure to raw water and water after treatment was used to estimate pipeline life expectancy. Approximations of the expected service life are shown in Tab 2. Estimated service life ranged from 14.57 to 23.52 m.year-1 for raw water and from 14.54 to 23.52 m.year-1 for water after treatment, with an annual average of 19.19 m.year-1 for raw water.

DISCUSSION

For short-time measurements, the difference is clear, as shown by the STN 75 7151 and the ASTM D2688-11 findings. Long-term (annual) observations, on the other hand, reveal almost identical rates of corrosion. In both kinds of testing, a greater average corrosion velocity was found in experiments using raw water than in studies using water that has undergone treatment (filter). From the seasonal temperature variation, it is clear that temperature changes in the water flowing through the corrosion devices affected the corrosion process of the specimens being examined. More severe corrosion effects were detected in short-term studies (30-60 days) than in longer measures (half-year and yearly). In order to designate water (both kinds, raw and treated after filtering) as being at the first level of aggressivity (moderately aggressive water – corrosion velocities to 50 m.year-1), annual measurement data are

referred to. Based on yearly testing coupons, the kind of corrosion was established. Raw water had a higher concentration of surface area corrosion, whereas water after treatment had a lower concentration of surface area corrosion and more substantial point corrosion. The yearly test findings were used to estimate the pipeline system's service life. The estimated yearly service life for raw water was 16.57 m.year-1 and for treated water was 19.18 m.year-1 on average in the study (after filtration)

CONCLUSIONS

The rusting of iron is a very complicated process. It's possible that one element is crucial in certain systems but not in others because of the wide range of situations. The corrosion of iron pipes in water distribution systems is exceedingly complex and is impacted by almost every physical, chemical, and biological component. Corrosion management is essential because distribution system pipes remain in situ for an extended length of time (> 50 years). Corrosion of the water supply pipeline is being monitored over an extended period of time in this project. Water temperature (or other seasonal conditions) was shown to have a significant impact on corrosion rates. Corrosion velocity measurements show that water aggressiveness fluctuated during the time period under study. Annual water aggressivity monitoring data show a reduction in corrosion velocity for both kinds of water in long-term testing compared to short-term studies. There is no need for additional measures to reduce the development of corrosion in pipelines.

REFERENCES

- [1] VREEBURG, J.,H.,G., *Discolouration in Drinking Water Systems: A Particular Approach. Department of Water Management. Delft, Delft University of Technology, The Netherlands, 2007, ISBN 978-90- 74741-91-0*
- [2] MUNKA, K., KARÁCSONYOVÁ, M., GAJDOŠ, E., *Poloprevádzkové hodnotenie vplyvu kvality vody na vybrané materiály prichádzajúce do styku s pitnou vodou. In: VodaZlín 2005. Sborník príspevků IX. mezinárodní vodohospodářské konference. Zlín, 7.-8.4.2005. Zlín: Zlínská vodárenská, a.s., 2005. s. 85- 90. ISBN 80-239-4453-3*
- [3] SLAVÍČKOVÁ, K., *Meření a hodnocení rychlosti koroze při procesů úpravy vody, In: Zborník príspevkov X. Medzinárodnej vodohospodárskej konferencie, VodaZlín 2006, s. 143-148. ISBN 80-239- 6523-9*
- [4] LYTLE, D. A., SCHOCK, M. R., *Impact of Stagnation Time on Metal Dissolution from Plumbing Materials in Drinking Water. Journal of water supply research and technology, 2000, AQUA 49(5):243- 257.*
- [5] VOLK, CH., DUNDORE, E., SCHIERMANN, J., LECHEVALLIER, M., *Practical evaluation of iron corrosion*

control in a drinking water distribution system, Water Research, Volume 34, No.6., Elsevier Science Ltd, 2000, s. 1967-1974, ISSN 0043-1354(99)00342-5

[6] FANG, C. S., LIU, B., (2003). *Hydrodynamic and temperature effects on the flow induced local corrosion rate in pipelines, Chemical Engineering Communications, Vol. 190, s. 1249-1266, ISSN 0098- 6445*

[7] SMITH, S.E., BISSET, A., COLBOURNE, J.S., HOLT, D.M., LLOYD, B.J., 1997. *The occurrence and significance of particles and deposits in a drinking water distribution system. Journal of the New England Water Works Association, 1997, Vol. 111 (2), 135-150* [8] MCNEILL, L.S., EDWARDS, M., 2001. *Iron pipe corrosion in distribution system, Journal – American Water Works Association, July 2001, s 88-100,*

[9] SINGLEY, J.,E., BEAUDET, B.,A., MARKEY, P.,H., *Corrosion Manual for Internal Corrosion of Water Distribution System, Environmental Science and engineering, INC., Florida, 1984, ESE No. 81-227-260*

[10] DEVIETTI, J.,L., *Modelling water quality in tropical water distribution systems. PhD thesis, James Cook University, 2011*

[11] STN 75 7151 Kvalitavody.
Požiadavky na kvalitu vody dopravovanej potrubím

[12] DUBOVÁ, V., ILAVSKÝ, J., BARLOKOVÁ, D.,
Sledovanie agresivity vody na VZ Pernek, Konferencia vodohospodárov v priemysle, Liptovský Ján, 2010, s. 217-224, ISBN 978-80-227-3393-6 [13] ASTM D2688-11
„Standard Test Method for Corrosivity of Water in the Absence of Heat Transfer“ (Weight Loss Method)