



**ISSN: 2454-9940**



**INTERNATIONAL JOURNAL OF APPLIED  
SCIENCE ENGINEERING AND MANAGEMENT**

**E-Mail :**  
**editor.ijasem@gmail.com**  
**editor@ijasem.org**

**[www.ijasem.org](http://www.ijasem.org)**

# A Novel Hybrid Fuzzy Logic Controller based RFLC for fault limiting in Transmission Networks and it's Dynamic Analysis

Shaik Fareed Ahmed, Asra Sultana, Syed Bader Anwar

## Abstract

*The introduction of the resonant fault current limiter (RFCL), which is based on fuzzy logic, is examined in the abstract. The fuzzy logic controller responds quickly and keeps errors close to zero. The ability of fuzzy can improve the stability of the system. According to the study's findings, RFCLs are useful tools for lowering the currents caused by failures in bulk power systems. Compared to a traditional PI controller-based RFCL network, the fuzzy logic controller-based RFCL transmission network has improved transient stability and dynamic stability. The MATLAB/Simulated software environment is used to test and assess the fuzzy system that is proposed.*

## Key word

Fuzzy logic controllers, transmission networks, fault analysis, network compression, RFLC, and stability are some relevant keywords.

## INTRODUCTION

The demand for electricity has been rising dramatically, and many nations are spending a lot of money to ensure a steady supply. The construction of more generation facilities and transmission links led to the complexity of the power networks increasing. Large-scale generation facilities and long-distance major transmission lines are both common. More transmission lines must be connected in order to handle higher loads. But those features of power systems have been contributing to issues with fault currents and system stability. In the distribution and transmission sections, a number of strategies are being tried to address the fault current issues. Analysis of fault current and stability has been investigated independently since network configuration affects both issues in the other direction. Fully meshing transmission systems tend to produce fault current issues rather than stability issues. On the other hand, stability issues rather than fault current issues may surface when power is transmitted through high impedance transmission

lines. However, those two issues coexist as power systems get more intricate thanks to mesh transmission networks that are connected by long-distance, high-power transmission lines. As a result, countermeasures to cope with the fault current have a greater impact than before on the stability of the power system. Future power systems will be significantly impacted by the importance of employing sustainable energy sources, which has already boosted the use of distributed generation (DG), microgrids, DC systems, and power electronic gadgets. These advancements increase the variety of electrical sources and loads, complicating system control and protection. In many cases, fault current levels will rise in order to accommodate these fundamental changes in future power systems. For instance, both grid and isolated networks need to be resilient against blackouts. This could be necessary among other things because greater electrical network interconnection typically results in higher fault current levels.

Asst. Professor<sup>1,2,3</sup>  
Department of EEE

[selectsfa@gmail.com](mailto:selectsfa@gmail.com), [asrasultana205@gmail.com](mailto:asrasultana205@gmail.com), [baderanwarsyed@gmail.com](mailto:baderanwarsyed@gmail.com)

[ISL Engineering College.](#)

International Airport Road, Bandlaguda, Chandrayangutta Hyderabad - 500005 Telangana, India.

The linking of DG can potentially drastically worsen coordination between protective systems and raise fault levels. Furthermore, power-dense marine vessel and aviation power systems have naturally high fault current levels. Operating a safe network safely in systems with a high fault level is quite difficult. Power system malfunctions have the potential to seriously harm both people and the equipment directly affected by the problem as well as any equipment transporting fault current. Higher fault currents result in higher circuit breaker expenses, hence circuit breakers must be rated to clear faults for a specific system fault current level. The use of fault current limiting in electrical systems is a crucial remedy for these problems. Normal power system functioning is normally not impacted by fault current limiter (FCL) devices, but they quickly take action to reduce destructive and other unfavourable impacts brought on by power system faults.

## RFCL DESIGN AND FUNCTION

One of the three stages of an RFCL's structure is shown in Fig. 1. To reduce the impact of the RFCL during usual activity, the design thunderous circuit consists of a current-limiting reactor and a full capacitor that are adjusted to the needed frequency of the power network. A small amount of stage movement is inevitable because it is very impossible to perfectly tune a resounding circuit. The diagram depicts a metal-oxide varistor, a bypass switch, and a thyristor-controlled bypass circuit in parallel to the capacitor. The thyristor valves are turned on and the current switches from the capacitor to the bypass circuit when a short-circuit fault is identified. In this manner, the RFCL's impedance quickly shifts from almost 0 (under normal operation) to the impedance of the reactor, maintaining the advancement of a large blame current. By comparing a part of the line current where the RFCL is located with a predetermined edge esteem, the cause is identified. On the other hand, it is possible to identify a fault using a combination of the current greatness, its pace of progress, and the duration of their occurrence. In contrast to conventional thyristors, a string of direct light activated thyristors used in the bypass circuit work in conjunction with a release current-limiting reactor and a damping resistor (see Fig. 3.1). These thyristor valves have a high ability during turn-on and are more likely to function at their maximum capacity with a simpler activating circuit. The design of the bypass circuit aims to

reduce motions of the release current while performing the bypass work as well as to limit the pace of progress of the release current and its maximum incentive after activating the thyristor valves. After a defect is detected, the bypass circuit keeps running the current.

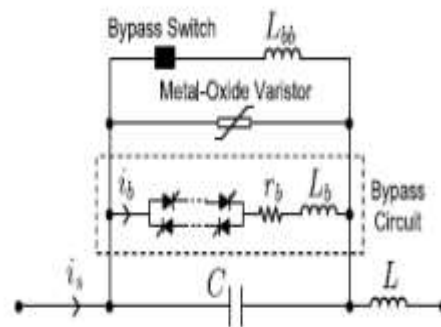

Fig-1. Design of a single phase RFCL.

When the fault is cleared by a successful tripping of the CB located near the fault location, the firing pulses of the thyristor valves are suppressed, and the capacitor is inserted into the circuit and, thus, the RFCL impedance reduces to zero. If the capacitor is required to remain bypassed for a longer period of time after the inception of the fault, then the bypass switch can be used to commutate the current from the bypass circuit. The inductor limits the rate of current commutation to the bypass switch. Also, the varistor should be properly rated to protect the capacitor against transient over voltages, whenever the capacitor is not bypassed. The IEEE nine-bus test power system, whose data are given, is illustrated in



its terminals across time, it is possible to determine how much energy a varistor absorbs over a transient time period. The system's time-domain simulation can then be used to achieve this. Since the varistors in this study are considered to have a perfect volt-ampere characteristic, the voltages across the capacitors are restricted even as additional current is passed via the varistors.

### CONTROLLER SCHEME FOR FUZZ

Because it can only calculate the error signal's instantaneous value without taking into account the error's rise and fall, which is represented mathematically by the derivative of the error denoted by, the disadvantage of the PI controller is its inability to respond to abrupt changes in the error signal,. Fuzzy logic control, as it is depicted in Fig. 3, is suggested as a solution to this issue. An inference engine with a rule base that contains if-then rules in the form of tables determines the output control signal. FLC stipulations.

$\epsilon$ $\Delta\epsilon$	NB	NM	NS	ZE	PS	PM	PB
NB	NB	NB	NB	NB	NM	NS	ZE
NM	NB	NB	NM	NM	NS	ZE	PS
NS	NB	NM	NS	NS	ZE	PS	PM
ZE	NB	NM	NS	ZE	PS	PM	PB
PS	NM	NS	ZE	PS	PS	PM	PB
PM	NS	ZE	PS	PM	PM	PB	PB
PB	ZE	PS	PM	PB	PB	PB	PB

"IF  $\epsilon$  is ..... AND  $\Delta\epsilon$  is ....., THEN output is ....."

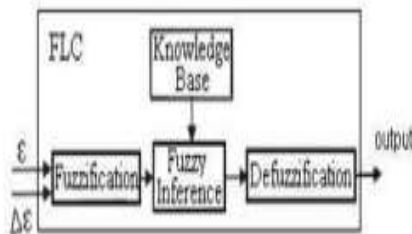

With the rule base, the value of the output is changed according to the value of the error signal  $\epsilon$ , and the rate-of-error  $\Delta\epsilon$ . The structure and determination of the rule base is done using trial-and-error methods and is also done through experimentation. All the variables' fuzzy subsets for the inputs  $\epsilon$  and  $\Delta\epsilon$  are defined as (NB, NM, NS, Z, PS, PM, PB). The fuzzy control rule is illustrated in the table I.

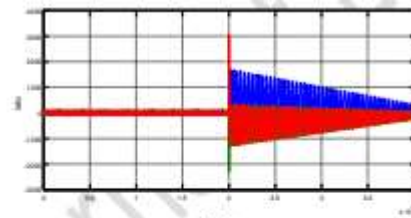

(a)

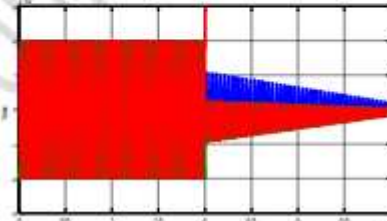

(b)

Fig. 4. Responses of the nine-bus system (left column) and its equivalent network (right column) to the strike of fault FltA with an RFCL in line L45.

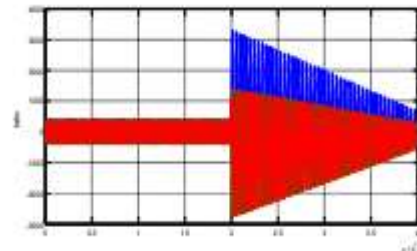
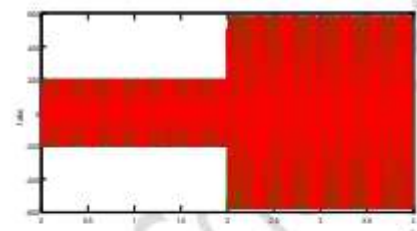
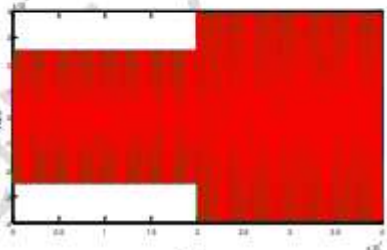

Fig. 5. Instantaneous currents through breaker CB5 in the nine-bus system (left column) and its equivalent network (right column) with the RFCL in line L45.



(a)



(b)

Fig. 6. Responses of the nine-bus system (left column) and its equivalent network (right column) to a 3LG fault at bus 7, respectively FltD (a) Line currents. (b) Capacitor voltages



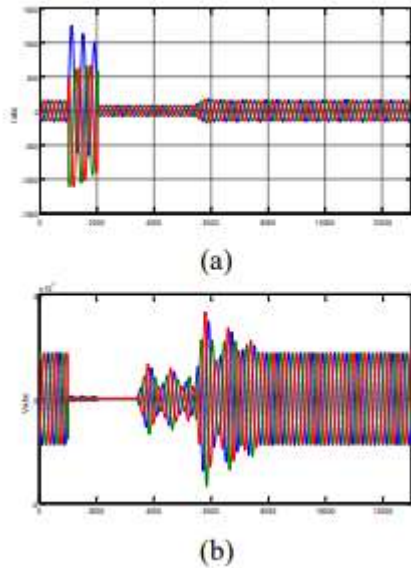

Fig.7. Responses of the nine-bus system subsequent to the strike of fault F1a.(a) Line currents. (b) Capacitor voltages.

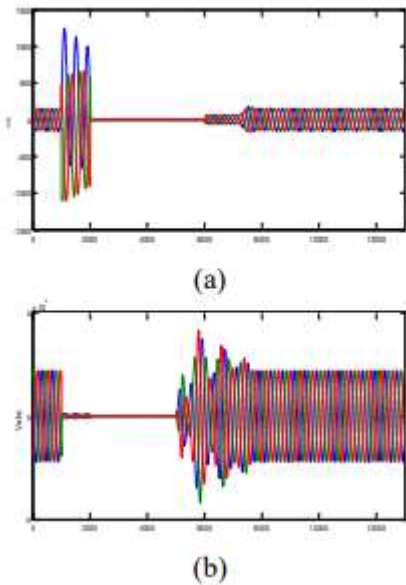

Fig.8. Responses of the nine-bus system subsequent to the strike of fault F1b.(a) Line currents. (b) Capacitor voltages.

It is observed that subsequent to the fault initially, the voltages across the capacitors increase due to the rise in the line current. Then, after the bypass valves are triggered, the line current commutates to the bypass circuit and the voltages across the capacitors drop. Fig. 2 plot the responses of the nine-bus test system in the two cases of without RFCL and with an RFCL in line L45, where at 0 s, fault strikes the system in each case. In the case of the RFCL, the protection-level voltage of the varistors is selected equal to two times the capacitor voltage under normal operation, that is, 43 kV, and the current threshold is equal to four times the current through line L45 under normal operation, that is, 800 A. It is observed that the responses of the nine-bus system and its equivalent

network, in the two cases, are in close agreement during the prefault and a quarter cycles after the inception of the fault. Fig.8 also plot the instantaneous currents through breaker CB5 in the nine-bus system in the two cases of without RFCL and with the RFCL in line L45. It is observed that the peak value of the current is reduced from 5 kA to 3.5 kA, that is, 30% reduction. Fig.8 illustrates the responses of the nine-bus system when the resonant capacitors are inserted in line L45 after the clearance of fault, under the assumption that the system is at steady state before 0 s. Thus, Fig.8 depicts that the responses of the nine-bus system and its equivalent network are generally in agreement despite the discrepancies. Since the capacitor voltages remain below, no energy is absorbed by the varistors.

## CONCLUSION

This paper discusses a thorough methodology for designing RFCLs in transmission networks that are based on fuzzy logic. On the basis of the simulated outcomes, the proposed fuzzy system is evaluated and examined. The proposed system's transient reaction is examined. According to the study's findings, RFCLs are useful tools for lowering the currents caused by failures in bulk power systems. Compared to a traditional PI controller-based RFCL network, the fuzzy logic controller-based RFCL transmission network has improved transient stability and dynamic stability.

## REFERENCES

- [1] S. Han, X. Mao, and L. He, "On modeling of high-voltage short circuit current limiter in East China power grid," in *Proc. IEEE Power Energy Soc. Gen. Meeting, Minneapolis, MN, USA, Jul. 25–29, 2010*, pp. 1–7.
- [2] CIGRE Working Group A3.10, "Fault current limiters in electrical medium and high voltage systems," 2003, CIGRE Tech. Brochure no. 239.
- [3] L. Ye and A. M. Campbell, "Case study of HTS resistive super conducting fault current limiter in electrical distribution systems," *Elect. Power Syst. Res.*, vol. 77, no. 5-6, pp. 534–539, Apr. 2007.
- [4] H. Liu, Q. Li, L. Zou, and W. H. Siew, "Impact of the inductive FCL on the interrupting characteristics of high-voltage CBs during out-of-phasfaults," *IEEE Trans. Power Del.*, vol. 24, no. 4, pp. 2177–2185, Oct. 2009. [5] V. Gor et al., "SCCL – A new type of FACTS based short-circuit current limiter for application in high voltage systems," in *Proc. CIGRE Session, 2004*, pp. 204–209.
- [6] A. Abramovitz and K. M. Smedley, "Survey of solid-state fault current limiters," *IEEE Trans. Power Electron.*, vol. 27, no. 6, pp. 2770–2782, Jun. 2012.
- [7] E. F. King, A. J. Chikhani, R. Hackam, and M. A. Salama, "A microprocessor controlled variable impedance adaptive fault current limiter," *IEEE Trans. Power Del.*, vol. 5, no. 4, pp. 1830–1837, Oct. 1990.

[8] S. Sugimoto et al., "Principle and characteristics of a fault current limiter with series compensation," *IEEE Trans. Power Del.*, vol. 11, no. 2, pp. 842–847, Apr. 1996.

[9] C. Meyer and R. W. De Doncker, "LCC analysis of different resonant circuits and solid-state circuit breakers for medium-voltage grids," *IEEE Trans. Power Del.*, vol. 21, no. 3, pp. 1414–1420, Jul. 2006.

[10] D. Das, D. Divan, and F. Lambert, "Integrated fault current limiter and power flow controller for grid tie-lines," in *Proc. IEEE Power Energy Soc. Gen. Meeting, Calgary, AB, Canada, Jul. 26–30, 2009*, pp. 1–7