



**ISSN: 2454-9940**



**INTERNATIONAL JOURNAL OF APPLIED  
SCIENCE ENGINEERING AND MANAGEMENT**

**E-Mail :  
editor.ijasem@gmail.com  
editor@ijasem.org**

**[www.ijasem.org](http://www.ijasem.org)**

# **ML&IOT BASED ENVIRONMENT MONITORING IN FACTORIES FOR EMPLOYEE SAFETY**

**CH VENKATESWARLU1, B. POOJITHA2, B. NEELIMA3, B. RAJITHA4**

---

## **ABSTRACT**

One of the most important considerations in the industry, in particular, is employee safety. The value of fresh air for employee satisfaction and health cannot be overestimated. Industrialization in India has led to increased levels of pollution, making it more difficult to maintain adequate air quality. It is necessary to take into account the ongoing economic development and rapid changes in population. All these factors lead to increased air pollution. Hazardous gases such as carbon monoxide not only endanger the health of employees but also prevent them from escaping to the environment. Employees are responsible and want to work at their own risk. We offer a tracking system as a solution to this problem. Through this invention, we oversee the safety aspects essential to this industrial activity and ensure that we are aware of the environmental conditions. Based on a series of events, use surveillance systems to conduct scientific research.

---

## **INTRODUCTION**

There has been a tremendous growth in the number of factories in all areas across India as a result of rapid industrial development. There are numerous issues that face factory workers who work in hazardous conditions. The Internet of Things is used to monitor the environment with the use of a microcontroller and multiple sensors to track environmental parameters [1]- [5]. It is essential to pay attention to temperature conditions and humidity levels in an environment.

Temperatures of between 20 and 27 degrees Celsius and relative humidity of between 35 and 60 percent are ideal for people, as extremes in either can cause suffocation and hinder their efficiency. The majority of enterprises rely on heavy machinery and high voltage electricity to run. Any deviation from typical operating circumstances could result in a probable health issue. As a result, we must continuously monitor the factory for indicators of any hazardous gases leakage. This is accomplished via sensors, which detect the presence of hazardous gases [6]-[8].

---

**ASSISTANT PROFESSOR 1, UG SCHOLAR2,3&4**

**DEPARTMENT OF ECE, MALLA REDDY ENGINEERING COLLEGE FOR WOMEN, HYDERABAD**

---

## EXISTING SYSTEM

In the existing system, sensors are strategically placed throughout the factory to capture environmental data. These sensors are often connected to a central monitoring system that allows supervisors to track conditions and respond to any anomalies or potential safety hazards. While this setup provides valuable data, it may not leverage the full potential of advanced analytics and real-time response capabilities.

The proposed ML and IoT-based system envisions the deployment of a network of interconnected sensors throughout the factory, feeding real-time data to an IoT platform. Machine Learning algorithms are then employed to analyze this data, identifying patterns, anomalies, or trends that may indicate potential safety risks. For example, the system could learn to predict and proactively address situations such as abnormal temperature increases, air quality deviations, or excessive noise levels.

Furthermore, the system could integrate wearable devices equipped with sensors to monitor individual employees' health and safety. These wearables could provide real-time data on parameters like heart rate and exposure to hazardous conditions. The ML

algorithms would analyze this data to ensure the well-being of workers, triggering alerts or automatic responses in case of emergencies.

While this ML and IoT-based approach holds promise for improving factory safety, challenges such as data privacy, algorithm accuracy, and system reliability need careful consideration. Ongoing developments in ML and IoT technologies, along with industry-specific standards, will likely play a crucial role in shaping the future of environment monitoring in factories for enhanced employee safety.

## LITERATURE SURVEY

**Ravi Kishore Kodali.: A Lost Cost Smart Irrigation System using MQTT Protocol.IEEE Explore.pp. 14-16 (2017)**

In India agriculture plays a very important role.The Indian economy is also greatly affected by agricultural, as about 50 percent of total population is directly or indirectly depend on the agricultural related activities. A farmer has to go to the farm to check the water level in the field and to turn on and turn off the water pump, sometimes even in the middle of the night. This problem can be overcome by improving old methods of farming. A new system can be developed or designed which transform the old traditional

farming into the smart farming. This paper tries to design a simple water pump controller by using a soil moisture sensor and Esp8266 NodeMCU-12E. A Message Queue Telemetry Transport protocol is used for transmitting and receiving sensor information. Depending on a status of soil moisture content NodeMCU-12E controls a water pump action and displays the soil moisture sensor data and water pump status on a web page or mobile application. In this way, a secure, flexible, trust-able and economical system is developed to solve above mentioned agricultural irrigation problem. Internet of things enables an explicit interconnection between various machines, devices, and Internet-based services and also this technology also help further exploited to benefit people to do work easily. According to Indian government Internet of thing policy, they plan to invest 15 billion in IoT up to 2020. Indian government policy also states that amidst another thing, IoT also helps to automate solutions to problems faced by various industries such as agriculture, automobile, manufacturing, banking, retail, disaster management and more, through remotely connected devices. This will lead to an increasing Internet-connected devices from 200 million to 2.7 billion in India up to 2020. According to

Gartner report, total revenue generated by IoT Industries would be 300 billion and connected devices would be 30 billion globally. It also assumes that India would have a share of 5-7 percent of global IoT industry market. Internet of thing has been providing its mettle across the industries such as agriculture, health services, energy, security, and banking. All the industries, one sector is rapidly increasing that is agriculture sector. The increase in an agricultural sector is due to an introduction of a concept of smart farming [19] [14],[15],[18] and digitalization. There are a wide range of IoT equipment available in the market for services like water resource management, tracking crop growth, smart route to detect pesticide spraying, high-tech laser-assisted precision land leveling, soil and plant monitoring [15], temperature, and humidity measurement [6],[9], remote control of pump sets in rural India and various other applications. But most of the pieces of equipment which are available in the market are costly and in a country like India where 80 percent of farmers are still small and marginal, buying this product for them is not economically viable. In India farmer of small landholding has to travel at odd hours in the middle of the night or in the early morning to switch on and switch off the water pump

when the power comes. The advantage of this system is that farmer can turn on and off the water pump by using Internet connectivity. In this system soil moisture sensor used [4],[8] for measuring the water content in the land and depend on water content pump state will decide, so there is no need of manually turn on and off of the water pump it automatically does by the server. In this project, we used the thinger.io platform for display soil moisture value and relay position in a web page and mobile app. We also used thinger.io platform extra features like a map, Donut chart, progress bar, and serial chart. Nowadays people are using IoT devices in homes, Agriculture[11], cars, industries, and many other places, so it is needed that our physical security and privacy 978-1-5090-6255-3/17/\$31.00 c 2017 IEEE should be maintained. In thinger.io platform inbuilt security provided by using Transport Layer Security (TLS) and Secure Socket Layer(SSL) cryptographic protocols and it is easily disabled also by using simple commands.

**Esakki Rajavel.: IOT Based Environmental Monitoring System, Asian Journal of Applied Science and Technology. Volume 2, Issue 2, Pages 461-467 (2018)**

The level of pollution has increased with times by lot of factors like the increase in population, vehicle use, industrialization and urbanization which results in harmful effects on human wellbeing by directly affecting health of the people. This project is based on the wireless sensor networks for collecting information about Environment. In order to monitor, we will develop an IOT Based Environmental Monitoring System, it can monitor the Air Quality over a web server by using the Wi-Fi Technology. Recent advancements like Internet of Things provide support for the transmission of huge and accurate amount of data regarding the Environment. In this IOT project, we can monitor the pollution level from anywhere through computer or mobile. This system not only calculates the pollutants present in the air, by using this we can forecast to avoid future pollution and can send the warning message to that particular polluted area. An Embedded System is a combination of computer hardware and software, and perhaps additional mechanical or other parts, designed to perform a specific function. An embedded system is a microcontroller-based, software driven, reliable, real-time control system, autonomous, or human or network interactive, operating on diverse physical variables and in diverse environments and

sold into a competitive and cost conscious market. An embedded system is not a computer system that is used primarily for processing, not a software system on PC or UNIX, not a traditional business or scientific application. High-end embedded & lower end embedded systems. High-end embedded system - Generally 32, 64 Bit Controllers used with OS. Examples Personal Digital Assistant and Mobile phones etc. Lower end embedded systems - Generally 8,16 Bit Controllers used with an minimal operating systems and hardware layout designed for the specific purpose. Examples Small controllers and devices in our everyday life like Washing Machine, Microwave Ovens, where they are embedded in.

**Ravi Kishore Kodali.: MQTT based environment monitoring in factories for employee safety. 3rd International Conference on Applied and Theoretical Computing and Communication Technology.pp. 21-23 (2017)**

Safety of employees, in any industry, especially at the factory level is one of the most important aspects to be considered by businesses. This is of paramount importance, both for the wellbeing of the employees and that of the corporation as a whole. In factories where working conditions are harsh and

employees need to take great caution while going about their work, it is common for mishaps to occur. With numbers going as high as into the thousands it is important that there is a measure of safety for the employees from any possible hazardous situations. As a solution to this problem, we propose a monitoring system to be installed in factories. With this system, we will be able to monitor critical safety parameters of the working environment in these factories so that we are well-aware of the safety situation and the possibility of occurrence of any mishap. For the design of this system, we use an ESP8266 Wi-Fi chip enabled microcontroller NodeMCU. To this are connected three sensors - one to monitor temperature and humidity ( DHT sensor ), an ultrasonic sensor ( HC-04 ) and a smoke sensor( MQ2 sensor ). these sensors continually monitor the environment in the workplace and upload the data onto the Losant IoT Platform, which is one of the most powerful cloud platforms which help monitor data by different visualizations and further provisions. With rapid industrial development, there has been a drastically increased number of factories all over India in all sectors. With this development, the spurious outburst of factories have unfortunately not been accompanied by the required and regulated

safety standards set by the National Policy on Safety, Health and Environment at Workplace. There are plenty of problems that plague the workers working in factories with hazardous environments. The main problems that affect the workers in a typical factory are the environmental conditions, namely, temperature and humidity, the presence of potentially harming and dangerous equipment used in the factory, and the possibility of a fire outbreak itself in the factory. So for a more employee-friendly and safe atmosphere to prevent accidents there is the need for a system which can continually monitor the situation in the factory and send the data in an understandable way to the concerned authorities so that they can monitor it and accordingly act when there is any mishap to avoid escalation of the problem or when there is the possibility of an accident and alert the concerned people to prevent it. The Internet of Things is what comes to the rescue here with us being able to monitor the environment with several sensors and upload the data so that it can be monitored. Temperature and humidity are two of the most basic aspects to be considered and maintained at specific levels so that employees do not feel uncomfortable and be prone to health risks. Most people feel comfortable in the temperature range of 20 to

27°C and a humidity range of 35-60%. Typically extreme levels of temperature and humidity cause workers to suffocate and prevent them from putting in their maximum effort. Some of the problems caused include muscle cramps, fatigue, irritation and headache. So there is a need to constantly monitor these parameters. Another main cause for factory accidents is the fact that employees tend to walk into areas where there are automated machinery. This leads to accidents where the workers stray into the range of the machine and are hit by it while it is working. Implementing sensors to detect if someone is approaching a possibly hazardous machine and warning him or her in advance would save the life of the employee and prevent these kind of accidents. Most factories operate with the help of heavy machinery and high power electricity to operate. This gives cause for a possible fire to break out with any deviation from normal working conditions. So we need to continuously monitor the factory for signs of a fire breaking out. This is done by smoke sensors which sense the presence of smoke when there is a fire. As a solution to these problems, this project implements the NodeMCU based on ESP8266 and monitors the various parameters for signs of possible accidents or mishaps in the factory and

aggregates all this data for further evaluation and processing to reach intelligent decisions. The data is uploaded on one of the most powerful and most popular IoT platform, Losant for aggregation and can be displayed in a user-friendly and easy-to-understand pattern, using their Dashboard option. Communication is done using the MQTT protocol which is lightweight in memory and consequently power consumption so that the system can be widely implemented at low costs on a large scale.

**Weizhe Zhang, Baosheng Qu.: Security Architecture of the Internet of Things Oriented to Perceptual Layer. International Journal on Computer, Consumer and Control. pp.37-45 (2017)**

One of the most important considerations in the industry, in particular, is employee safety. The value of fresh air for employee satisfaction and health cannot be overestimated. Industrialization in India has led to increased levels of pollution, making it more difficult to maintain adequate air quality. It is necessary to take into account the ongoing economic development and rapid changes in population. All these factors lead to increased air pollution. Hazardous gases

such as carbon monoxide not only endanger the health of employees but also prevent them from escaping to the environment. Employees are responsible and want to work at their own risk. We offer a tracking system as a solution to this problem. Through this invention, we oversee the safety aspects essential to this industrial activity and ensure that we are aware of the environmental conditions. Based on a series of events, use surveillance systems to conduct scientific research. There has been a tremendous growth in the number of factories in all areas across India as a result of rapid industrial development. There are numerous issues that face factory workers who work in hazardous conditions. The Internet of Things is used to monitor the environment with the use of a microcontroller and multiple sensors to track environmental parameters [1]- [5]. It is essential to pay attention to temperature conditions and humidity levels in an environment. Temperatures of between 20 and 27 degrees Celsius and relative humidity of between 35 and 60 percent are ideal for people, as extremes in either can cause suffocation and hinder their efficiency. The majority of enterprises rely on heavy machinery and highvoltage electricity to run.



Any deviation from typical operating circumstances could result in a probable health issue. As a result, we must continuously monitor the factory for indicators of any hazardous gases leakage. This is accomplished via sensors, which detect the presence of hazardous gases.

## IMPLEMENTATION

### Block diagram

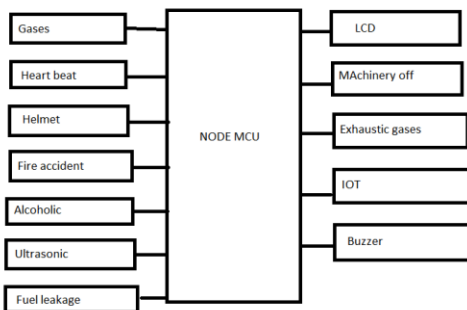

The proposed ML and IoT-based environment monitoring system for factories aims to revolutionize employee safety by leveraging advanced technologies for real-time insights and proactive hazard prevention. In this envisioned system, a network of sensors strategically deployed throughout the factory continuously collects data on various environmental parameters, such as temperature, humidity, air quality, and noise levels. These sensors are integrated into an IoT platform, creating a connected ecosystem.

Machine Learning algorithms form the core intelligence of the system, analyzing the streaming data to identify patterns indicative of potential safety risks. The ML models can learn from historical data and detect anomalies in real-time, enabling the system to predict and address safety concerns before they escalate. For instance, sudden temperature spikes or deviations in air quality could trigger automated responses, such as adjusting ventilation systems or alerting relevant personnel.

In addition to environmental sensors, wearable devices equipped with biometric sensors are incorporated into the system to monitor individual employee health and

safety. These wearables provide real-time data on metrics like heart rate and exposure to hazardous conditions. The ML algorithms analyze this personal data, generating insights into individual well-being and potential health risks. In emergency situations, the system can automatically trigger alarms, notify response teams, or initiate evacuation procedures.

This ML and IoT-based approach not only enhances the overall safety of the factory environment but also enables a more

personalized approach to employee well-being. However, challenges such as ensuring data security, refining algorithm accuracy, and addressing privacy concerns must be carefully addressed during the development and implementation of such a system. Ongoing advancements in ML, IoT, and wearable technologies are expected to play a pivotal role in shaping the proposed system and establishing new benchmarks for employee safety in factories.

## CONCLUSION

The DHT11 is a single-wire digital humidity and temperature sensor that outputs humidity and temperature values via a one-wire protocol and reads temperature and humidity measurements via the Arduino's second port. Temperature, Humidity, Air Quality Index, Dust Density, Carbon Dioxide, Carbon Monoxide, and Methane ppm Levels are all displayed on the LCD display. The level will be monitored, and if it reaches a dangerous level, the system will send out an alarm and activate the buzzer. The buzzer will sound until the atmosphere returns to normal. The system's WIFI module is used to send data through TCP to an online server in order to monitor factory environmental parameters. Through this analysis, we send the data to the server using IoT and used for further

reference. The data is available for industrial purpose to monitor the environment safety of employees. The data from the cloud are fetched and represented in the tabular view and sketched with the linear graphs. These graphs help to identify the peak and drop of levels at a particular time period. The system's ultimate aim to maintain the atmospheric Air Quality Level in the environment.

## REFERENCES

- [1] Ravi Kishore Kodali.: A Lost Cost Smart Irrigation System using MQTT Protocol.IEEE Explore.pp. 14-16 (2017)
- [2] Esakki Rajavel.: IOT Based Environmental Monitoring System, Asian Journal of Applied Science and Technology.Volume 2, Issue 2, Pages 461-467 (2018)
- [3] Ravi Kishore Kodali.: MQTT based environment monitoring in factories for employee safety. 3rd International Conference on Applied and Theoretical Computing and Communication Technology.pp. 21-23 (2017)
- [4] Weizhe Zhang, Baosheng Qu.: Security Architecture of the Internet of Things Oriented to Perceptual Layer. International

Journal on Computer, Consumer and Control.  
pp.37-45 (2017)

[5] R. Rajalakshmi and J. Vidhya.: Toxic Environment Monitoring Using Sensors Based on Arduino. IEEE International Conference on System, Computation, Automation and Networking. pp. 1-6 (2019)

[6] M. S. Amin, S. T. H. Rizvi, U. Iftikhar, S. Malik and Z. B. Faheem.: IoT Based Monitoring and Control in Smart Farming. Mohammad Ali Jinnah University International Conference on Computing.pp. 1-6 (2021)